

## INFORMAZIONI GENERALI

Il presente catalogo serve per richiedere con esattezza le parti di ricambio.

Nelle ordinazioni indicare:

- 1) il numero di codice dei particolari seguito dalla descrizione;
- 2) il **codice colore, riportato sull'adesivo applicato all'interno del vano porta oggetti;**
- 3) il numero di matricola del motociclo, stampigliato sul canotto di sterzo.

Le indicazioni destra e sinistra si riferiscono ai lati del veicolo rispetto al senso di marcia.

I particolari sono completi di adesivi.

## GENERAL INFORMATION

The present spare parts list enables one to order exactly the right spare parts.

When ordering specify:

- 1) the part's code number followed by its description;
- 2) **the colours code given on the adhesive stuck inside tool back;**
- 3) the motorcycle's serial number, stamped on the steering head.

References to right and left apply to the vehicle in terms of its direction of movement.

Parts are provided with trim.

## INFORMATIONS GENERALES

Ca catalogue permet de commander correctement les pièces de rechange.

Les commandes doivent être passées en indiquant:

- 1) le numéro de code des pièces détachées suivi de leur description;
- 2) **le code couleur indiqué sur l'adhésif appliqué à l'intérieur de la boîte a gants;**
- 3) le matricule de la moto, estampillé sur la tige du guidon.

Droite et gauche sont les côtés du véhicule par rapport au sens de la marche.

Les pièces sont complets des decalcomanies.

## ALLGEMEINE HINWEISE

Dieser Ersatzteilkatalog dient zur genauen Angabe der Teile bei Ersatzteilbestellungen.

Bei Ersatzbestellung ist folgendes anzugeben:

- 1) Die Bestellnummer der Ersatzteile mit der entsprechenden Beschreibung;
- 2) **Farbenkode, angegeben auf dem kleber im Werkzeugfach.**
- 3) Die Sseriennummer des Motorrades, die am Lenkrohr eingepreßt ist.

Die Angaben rechts und links beziehen sich auf das Fahrzeug in Fahrrichtung.

Die Detail sind von abriebbild vollständig.

## INFORMACIONES GENERALES

El presente catálogo sirve para pedir con exactitud las partes de recambio.

En los pedidos se debe indicar:

- 1) el número de código de la parte y a continuación la descripción;
- 2) el código de color, que se encuentra en el adhesivo aplicado dentro del cajetín.
- 3) el número de matrícula de la motocicleta, estampado en le tubo de dirección.

Las indicaciones derecha e izquierda se refieren a los lados del vehículo respecto del sentido de marcha.

Los particulares estan completos de calcomanias.

## NOTE - LIST - NOTES - NOTE - NOTAS:

F.m. :Fino alla matricola - Until V.I.N. - Jusqu'au matricule - Bis zu Matrikel - Hasta la matrícula

D.m. : Dalla matricola - From V.I.N. - Du matricule - Vom Matrikel - Desde la matrícula

Z : n° denti, number of teeth, numéro dents, Zähne nummer, número dientes

A : Austria, Austria, Autriche, Österreich, Austria

AUS : Australia, Australia, Australie, Australien, Australia

B : Belgio, Belgium, Belgique, Belgien, Bélgica

BR : Brasile, Brazil, Brasile, Brasilien, Brasil

CND : Canada, Canada, Canada, Kanada, Canadá

CH : Svizzera, Switzerland, Suisse, Schweizer, Suiza

D : Germania, Germany, Allemagne, Deutschland, Alemania

E : Spagna, Spain, Espagne, Spanien, España

F : Francia, France, France, Frankreich, Francia

GB : Gran Bretagna, Great Britain, Grand Bretagne, Groos Britan, Gran Bretaña

I : Italia, Italy, Italie, Italien, Italia

INA : Indonesia, Indonesia, Indonesie, Indonesien, Indonesia

MAL : Malesia, Malaysia, Malaysie, Malaysia, Malasia

TA : Tahiti, Tahiti, Tahiti, Tahiti, Tahiti

USA : Stati Uniti d'America, United States of America, Etats Units d'Amerique,

Verenigte Staaten von Amerika, Estados Unidos

SF : Finlandia, Finald, Finlande, Finnland, Finlandia

ZA : Sudafrica, South Africa, Afrique du sud, Südafrika, Sudafrica

Il n° di matricola iniziale del motociclo **MITO EV - 01** versione 11Kw é **ZCGN300AA\*V000001**

Il n° di matricola iniziale del motociclo **MITO EV - 01** versione piena potenza é **ZCGN300AB\*V000001**

Initial part number for the motorcycle **MITO EV - 01** 11Kw version is **ZCGN300AA\*V000001**

Initial part number for the motorcycle **MITO EV - 01** 11Kw full power version is **ZCGN300AB\*V000001**

Le prime numéro de matricule de la moto **MITO EV - 01** version 11Kw est **ZCGN300AA\*V000001**

Le prime numéro de matricule de la moto **MITO EV - 01** version plein poissance est **ZCGN300AB\*V000001**

Die Nummer der Anfangsmatrikel vom Motorrad **MITO EV - 01** 11Kw ist **ZCGN300AA\*V000001**

Die Nummer der Anfangsmatrikel vom Motorrad **MITO EV - 01** Potenzfreiversion ist **ZCGN300AB\*V000001**

El n° de matrícula inicial de la moto **MITO EV - 01** versión 11Kw es **ZCGN300AA\*V000001**

El n° de matrícula inicial de la moto **MITO EV - 01** versión piena potencia es **ZCGN300AB\*V000001**

Codice colore "B" Rosso Nero - Color code "B" Red Black - Code couleur "B" Rouge Noir - Code Farbe "B" Rot Schwarz

Código de color "B" Rojo Negro.

Codice colore "E" Giallo Fly - Color code "E" Yellow Fly - Code couleur "E" Jaune Fly - Code Farbe "E" Gelb Fly

Código de color "E" Amarillo Fly.

Codice colore "F" Nero metallizzato - Color code "F" Metalized Black - Code couleur "F" Noir métallisé

Code Farbe "F" Metallisierte Schwarz - Código de color "F" Negro metalizado.

Dati indicativi soggetti a modifiche senza impegno di preavviso.

All data are subject to modification without prior notice.

Données indicatif sujet au modifications sans obligation de préavis.

Anderungen Vorbehalten.

Datos indicativos sujetos a modificaciones sin compromiso de preaviso.

Tavola Drawing Table Bild Tabla	Denominazione	Description	Designation	Bezeichnung	Denominacion	Pag
1	ATTREZZI DI ASSISTENZA .....	SERVICE TOOLS .....	OUTILSD'ASSISTANCE .....	HILFAUSRUSTUNG .....	HERRAMIENTAS DE ASISTENCIA .....	11
2	TESTA, CILINDRO, PISTONE, .....	CYLINDER HEAD, CYLINDER, PISTON, .....	CULASSE, CYLINDRE, PISTON, .....	ZYLINDERKOPF, ZYLINDER, KOLBEN, .....	CULATA, CILINDRO, PISTON .....	15
	MANOVELLISMO .....	CRANKSHAFT .....	VILEBREQUIN .....	KURBELWELLE .....	PALANCAS .....	
3	DISTRIBUZIONE .....	VALVE TIMING .....	DISTRIBUTION .....	VENTILSTEUERUNG .....	DISTRIBUCION .....	23
4	RAFFREDDAMENTO .....	COOLING .....	REFROIDISSEMENT .....	WASSERKÜHLUNG .....	ENFRIAMIENTO .....	25
5	BASAMENTO .....	CRANKCASE .....	CARTER .....	GEHAUSE .....	BANCADA .....	29
6	COPERCHI BASAMENTO .....	CRANKCASE COVERS .....	COUVERCLES CARTER .....	GEHAUSEDECKEL .....	TAPABANCADA .....	33
7	FRIZIONE, CONTRALBERO, .....	CLUTCH, LAYSCHAFT .....	EMBRAYAGE, ARBRE DE BAL .....	KUPPLUNG, VORGELEGEWELLE .....	ENBRAGUE, CONTRA-EJE .....	35
	TRASM. PRIMARIA .....	PRIMARY DRIVE .....	TRANSMISS. PRIMARIE .....	ERSTERANTRIEB .....	TRANSM. PRIMARIA .....	
8	CAMBIO .....	TRANSMISSION .....	BOITE DE VITESSE .....	WECHSELGETRIEBE .....	CAMBIO .....	39
9	COMANDO CAMBIO .....	SHIFTER .....	COMMANDE DE VITESSE .....	GANGSCHALTUNG .....	MANDO CAMBIO .....	43
10	LUBRIFICAZIONE .....	LUBRICATION .....	GRAISSAGE .....	SCHMIERUNG .....	LUBRICACION .....	47
11	MOTORINO AVVIAMEN., ALTERNATORE .....	ALTERNATOR, STARTING MOTOR .....	MOTEUR DE DEMARRAGE, ALTERN. ....	ALTERNATORANLAßMOTOR .....	MOTOR DE ARRANQUE, ALTERNADOR .....	49
11A	MOTORINO AVVIAMEN., ALTERNATORE .....	ALTERNATOR, STARTING MOTOR .....	MOTEUR DE DEMARRAGE, ALTERN. ....	ALTERNATORANLAßMOTOR .....	MOTOR DE ARRANQUE, ALTERNADOR .....	53
11B	AVVIAMENTO A PEDALE .....	KICK START .....	DEMARRAGE A PEDALE .....	KICKANLASSER .....	ARRANQUE A PEDAL .....	55
12	CARBURATORE DELL' ORTO .....	CARBURETOR DELL' ORTO .....	CARBURATEUR DELL' ORTO .....	VERGASER DELL' ORTO .....	CARBURADOR DELL' ORTO .....	57
13	SCATOLA FILTRO ARIA .....	AIR FILTER BOX .....	BITE FILTRE AIRE .....	FILTERKASTEN .....	CAJAFILTRO AIRE .....	63
14	TELAIO, ANTERIORE .....	FRAME .....	CHASSIS .....	RAHMEN .....	BASTIDOR, REPOSAPIES .....	65
15	TELAIO, POSTERIORE .....	REAR FRAME SIDE .....	CHASSIS ARRIERE .....	SATTEMBRÜCKE .....	CUADRO POSTERIOR .....	69
16	SOSPENSIONE ANTERIORE .....	FRONT FORK ASSEMBLY .....	SUSPENSION AVANT .....	VORDETELESKOPGABEL .....	SUSPENSION DELANTERA .....	73
17	FORCELLONE .....	SWING .....	FOURCHE .....	GABEL .....	HORQUILLA .....	75
18	SOSPENSIONE POSTERIORE .....	REAR SUSPENSION .....	SUSPENSION ARRIERE .....	HINTERAUFHANGUNG .....	SOUSPENSION TRASERA .....	77
19	COMANDI LATO SINISTRO .....	LEFT CONTROLS .....	COMMANDES GAUCHE .....	LINKSSEITIGE BEDIENTEILE .....	MANDO LADO IZQUIERDO .....	79
20	COMANDI LATO DESTRO .....	RIGHT CONTROLS .....	COMMANDES DROITE .....	RECHTSSEITIGE BEDIENTEILE .....	MANDO LADO DERECHO .....	81
21	FRENO ANTERIORE .....	FRONT BRAKE .....	FREIN AVANT .....	VORDERRADBREMSE .....	FRENO DELANTERO .....	83
22	FRENO POSTERIORE .....	REAR BRAKE .....	FREIN ARRIERE .....	EINSTELLUNG .....	FRENO TRASERO .....	85
23	RUOTA ANTERIORE .....	FRONT WHEEL .....	ROUE AV .....	VORTERRAD .....	RUEDA DELANTERA .....	87
24	RUOTA POSTERIORE .....	REAR WHEEL .....	ROUE ARRIERE .....	HINTERRAD .....	RUEDA TRASERA .....	89
25	SERBATOIO ALIMENTAZIONE .....	GAS TANK, FEED .....	RESERVOIR, ALIMENTATION .....	KRAFTSTOFFBEHALTER, ZUFUEHRUNG .....	DEPOSITO, ALIMENTACION .....	93
26	SCARICO .....	EXHAUST SYSTEM .....	TUYAUD'ÉCHAPPEMENT .....	AUSPUFFROHR .....	TUBO DE ESCAPE .....	97
27	FARO ANTERIORE .....	HEADLAMP-FRONT .....	FHARE-AVANT .....	SCHINWERFER-VORDER .....	FARO DELANTERO .....	101
28	IMPIANTO ELETTRICO .....	ELECTRIC SYSTEM .....	INSTALLATION ELECTRIQUE .....	ELEKTRISCHE ANLAGE .....	INSTALACION ELECTRICA .....	105
29	STRUMENTI .....	INSTRUMENTS .....	INSTRUMENTS .....	INSTRUMENTE .....	INSTRUMENTOS .....	111
30	CARENATURA POSTERIORE .....	REAR FAIRING .....	CARENAGE POST. ....	HINTERSCHALE .....	CARROCERIA TRASERA .....	115

Tavola Drawing Table Bild Tabla	Denominazione	Description	Designation	Bezeichnung	Denominacion	Pag
31	CARENATURA	FENDERS	CARENATURE	VERKLEIDUNG	CARENADO	119
32	AMMORTIZZATORE DI STERZO	SHOCK ABSORBER	AMMORTISEUR	STOSSDAMPFFER	ARMOTIGUADOR	123
33	DECALC. PER COD. COL. B - F	TRIM FOR COLOR CODE B - F	DECALCOMANIE POUR CODE COL. B - F	ABZIEHBILD FUR CODE FARBE B - F	CALCOMANIAS PARA COD. COLOR B - F	125
33A	DECALC. PER COD. COL. E	TRIM FOR COLOR CODE E	DECALCOMANIE POUR CODE COL. E	ABZIEHBILD FUR CODE FARBE E	CALCOMANIAS PARA COD. COLOR E	127

**TABELLA CODICI COLORE - COLOUR CODE TAB - TABLEAU CODE COLEUR - FARBENTABELLE - TABLA CODIGOS DE COLOR**

Codice CAGIVA CAGIVA code Code CAGIVA Code CAGIVA Codigo CAGIVA	Fornitore Supplier Fournisseur Fournisseur Abastecedor	Codice Fornitore Supplier code Code fournisseur Code Fournisseur Codigo abastecedor	Colore	Colour	Coleur	Farbe	Colòr
8D67	SALCHI	6536033	Grigio quartz	Quartz grey	Gris quartz	Quartz Grau	Gris quartz
8D83	SALCHI	5394039	Giallo Fly	Yellow Fly	Jaune Fly	Gelb Fly	Amarillo Fly
8D90	SALCHI	8366286	Antracite	Anthracite	Anthracite	Anthrazit	Antracita
8E05	PPG	195/A	Bianco Dakar	Dakar White	Blanc Dakar	Dakar Weiss	Blanco Dakar
8E11	SALCHI	5395058 L2719	Rosso Lucky	Lucky red	Rouge Lucky	Lucky Rot	Rojo Lucky
8E38	PPG	FTI 0697 / FTI 473201	Giallo	Yellow	Jaune	Gelb	Amarillo
8E43	PPG	473103	Rosso CAGIVA	CAGIVA red	Rouge CAGIVA	CAGIVA Rot	Rojo CAGIVA
8E60	PPG	SC 20-28	Nero opaco	Matt black	Noir opaque	Mattschwarz	Negro opaco
8E61	PPG	AC-708 (ALFA R.) +30%gloss	Grigio	Grey	Gris	Grau	Gris
8E64	PPG	HONDA NH.516 M NOBLE SILVER MET. 2 CT	Argento	Silver	Argent	Silber	Plateado
8E80	PPG	FIAT BLU IMOLA MET. 2 CT FIA 481/A	Blu	Blue	Bleu	Blau	Azùl
8F03	SALCHI	3327078	Nero metallizzato	Metalized Black	Noir metalisé	Metallisierte Schwarz	Negro metalizado
8G40	8D05 SALCHI	539009	Bianco Dakar	Dakar White	Blanc Dakar	Dakar Weiss	Blanco Dakar
	8E11 SALCHI	5395058	Rosso Lucky	Lucky red	Rouge Lucky	Lucky Rot	Rojo Lucky
8G58	8E38 PPG	FTI 0697 / FTI 473201	Giallo	Yellow	Jaune	Gelb	Amarillo
	8E60 PPG	Austin rover S1 914 PMT bumper black AC 20-28	Nero opaco	Matt black	Noir opaque	Mattschwarz	Negro opaco
8G59	8E43 PPG	473.103	Rosso CAGIVA	CAGIVA red	Rouge CAGIVA	CAGIVA Rot	Rojo CAGIVA
	8E62 PPG	PIN FIAT 241	Bianco	White	Blanc	Weiss	Blanco
8G61	8E38 PPG	FTI 473201	Giallo	Yellow	Jaune	Gelb	Amarillo
	8E62 PPG	FTI 0697 PIN FIAT 241	Bianco	White	Blanc	Weiss	Blanco
8G63	8D83 SALCHI	5394039	Giallo Fly	Yellow Fly	Jaune Fly	Gelb Fly	Amarillo Fly
	8E62 PPG	PIN FIAT 241	Bianco	White	Blanc	Weiss	Blanco

Tavola - Drawing - Table - Bild - Tabla

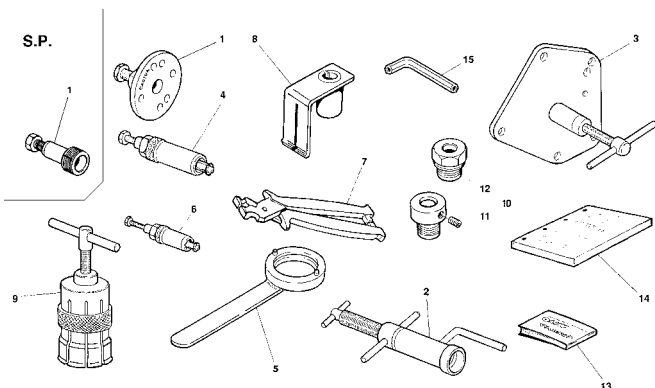
**1**

Pagina - Side - Page - Seite - Paja

**10**

Tavola - Drawing - Table - Bild - Tabla

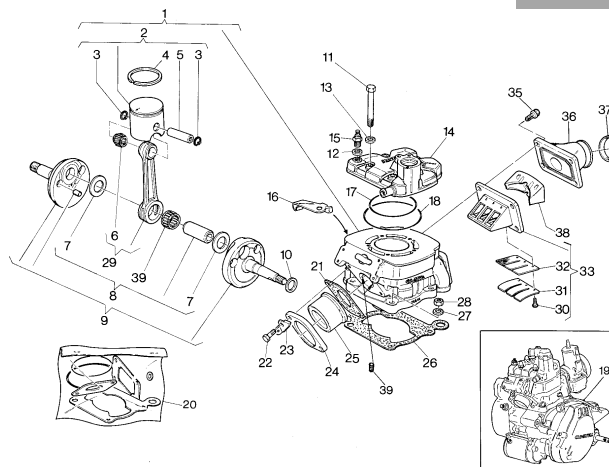
**2**

Pagina - Side - Page - Seite - Paja

**14**

Tavola - Drawing - Table - Bild - Tabla

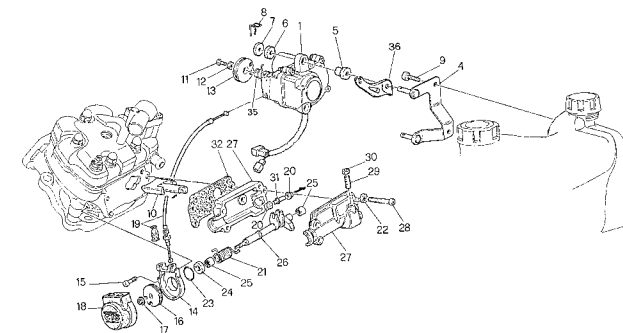
**3**

Pagina - Side - Page - Seite - Paja

**22**

Tavola - Drawing - Table - Bild - Tabla

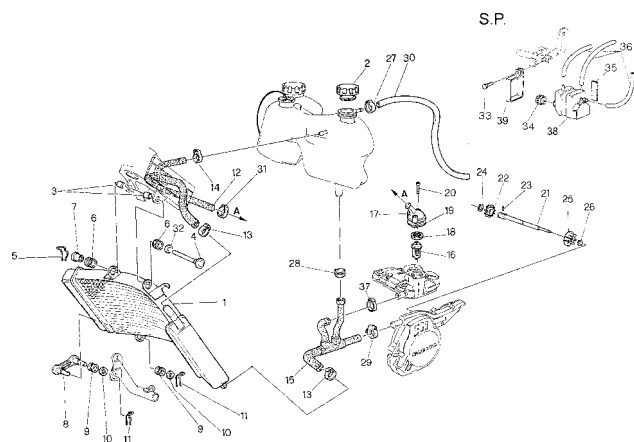
**4**

Pagina - Side - Page - Seite - Paja

**24**

Tavola - Drawing - Table - Bild - Tabla

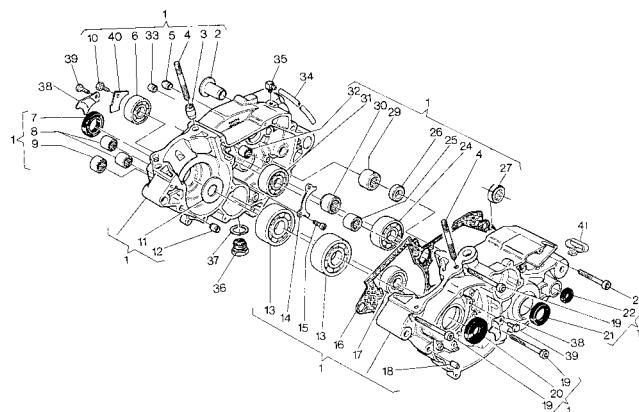
**5**

Pagina - Side - Page - Seite - Paja

**28**

Tavola - Drawing - Table - Bild - Tabla

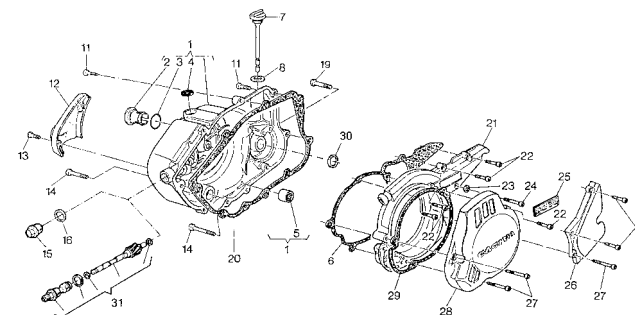
**6**

Pagina - Side - Page - Seite - Paja

**32**

Tavola - Drawing - Table - Bild - Tabla

**7**

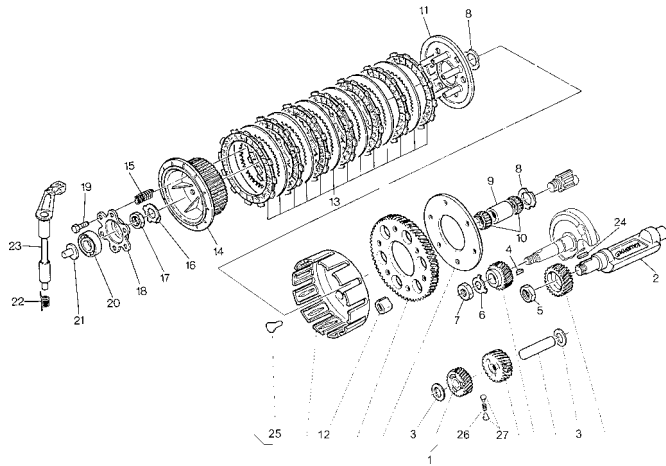

Pagina - Side - Page - Seite - Paja

**34**

Tavola - Drawing - Table - Bild - Tabla

**8**

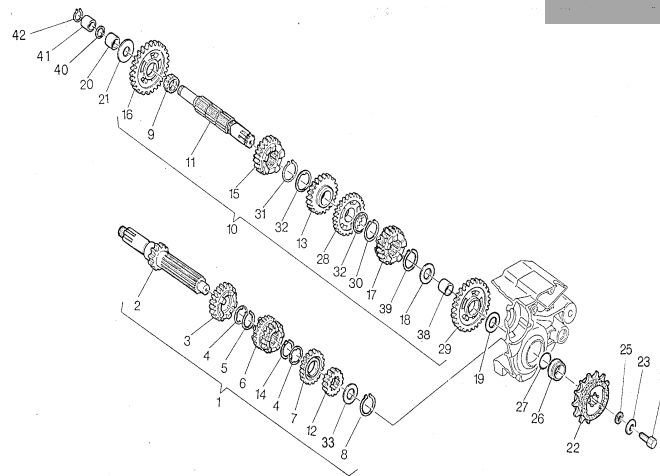

Pagina - Side - Page - Seite - Paja

**38**

Tavola - Drawing - Table - Bild - Tabla

**9**

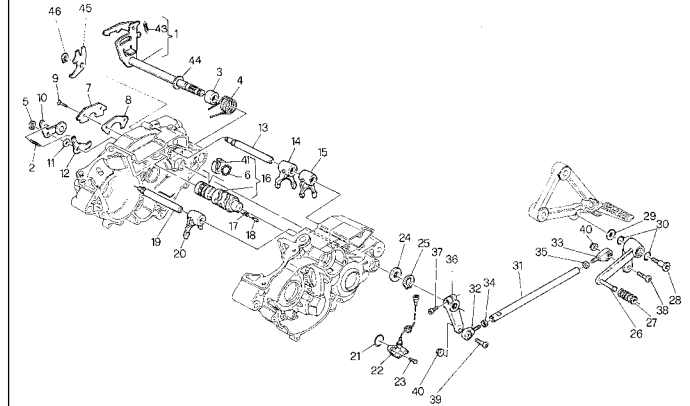

Pagina - Side - Page - Seite - Paja

**42**

Tavola - Drawing - Table - Bild - Tabla

**10**

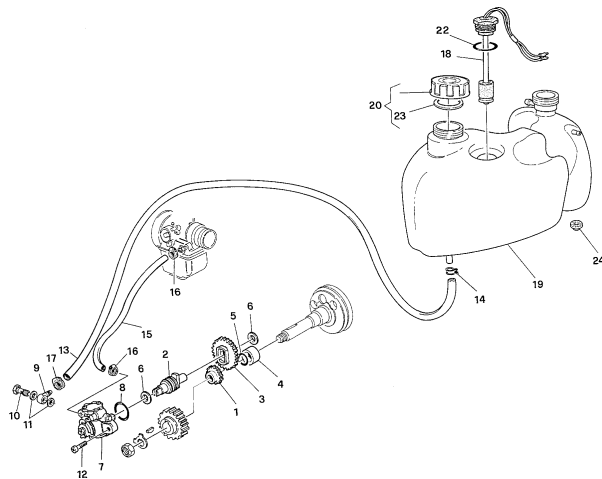

Pagina - Side - Page - Seite - Paja

**46**

Tavola - Drawing - Table - Bild - Tabla

**11**

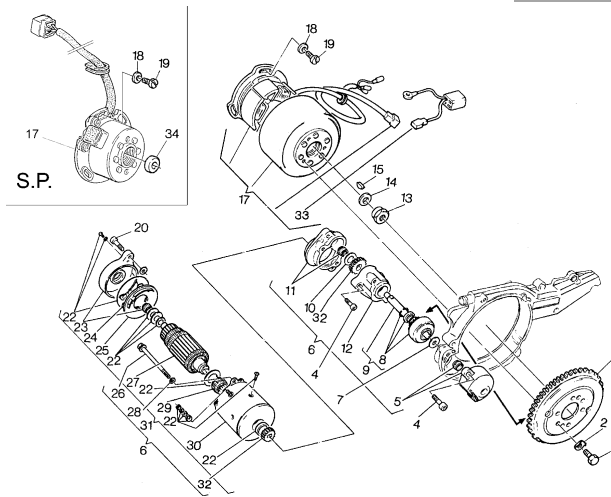

Pagina - Side - Page - Seite - Paja

**48**

Tavola - Drawing - Table - Bild - Tabla

**11A**

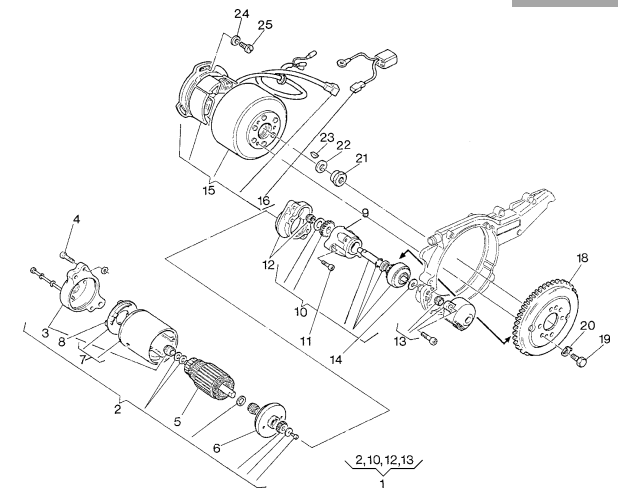

Pagina - Side - Page - Seite - Paja

**52**

Tavola - Drawing - Table - Bild - Tabla

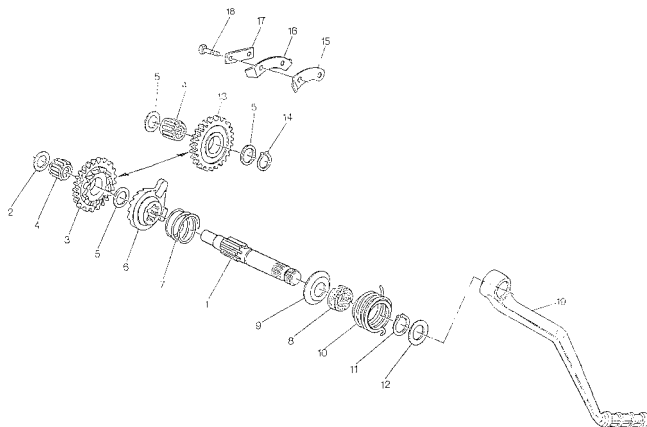
**11B**

Pagina - Side - Page - Seite - Paja

**54**

Tavola - Drawing - Table - Bild - Tabla

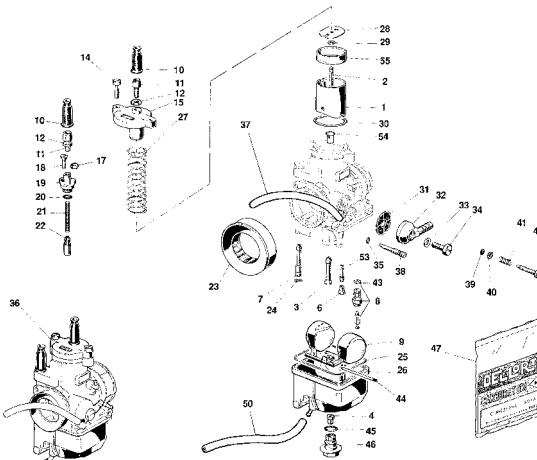
**12**

Pagina - Side - Page - Seite - Paja

**56**

Tavola - Drawing - Table - Bild - Tabla

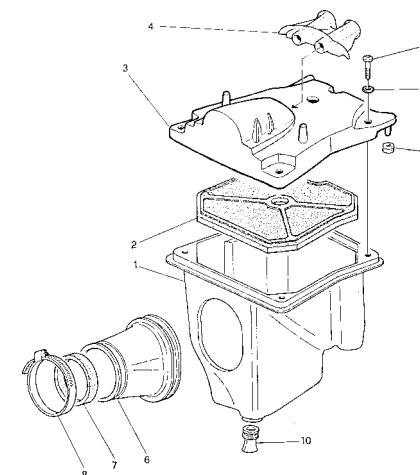
**13**

Pagina - Side - Page - Seite - Paja

**62**

Tavola - Drawing - Table - Bild - Tabla

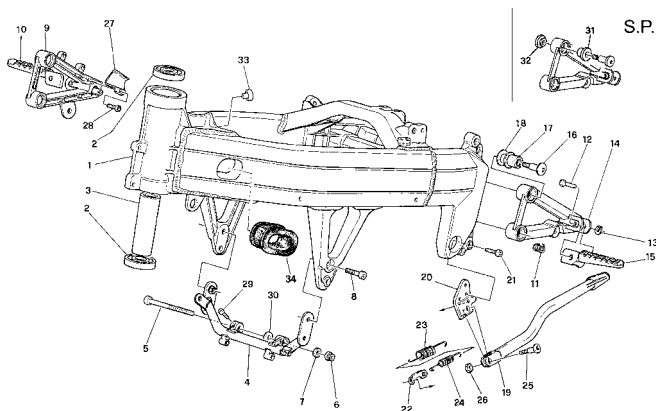
**14**

Pagina - Side - Page - Seite - Paja

**64**

Tavola - Drawing - Table - Bild - Tabla

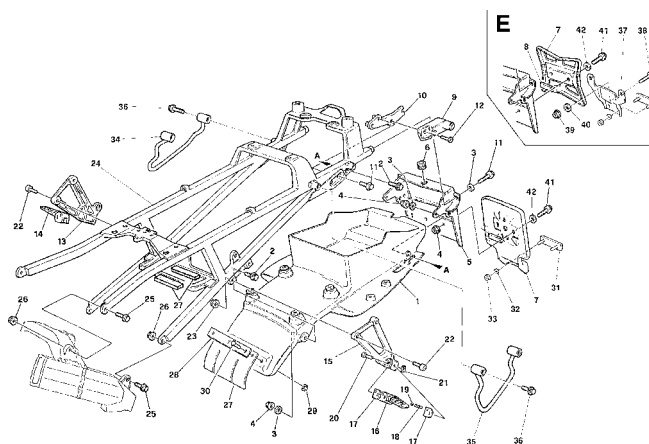
**15**

Pagina - Side - Page - Seite - Paja

**68**

Tavola - Drawing - Table - Bild - Tabla

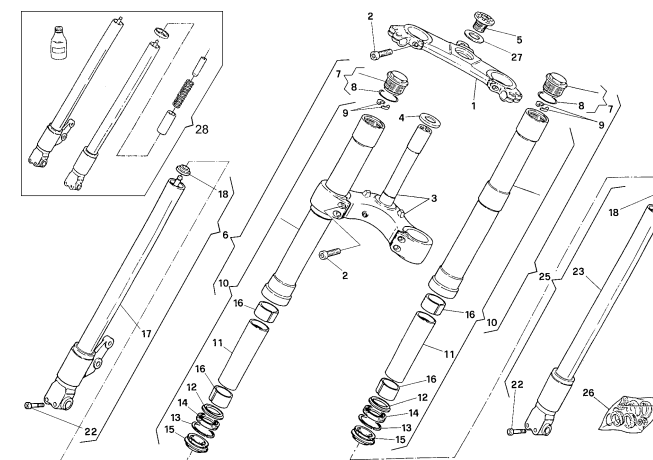
**16**

Pagina - Side - Page - Seite - Paja

**72**

Tavola - Drawing - Table - Bild - Tabla

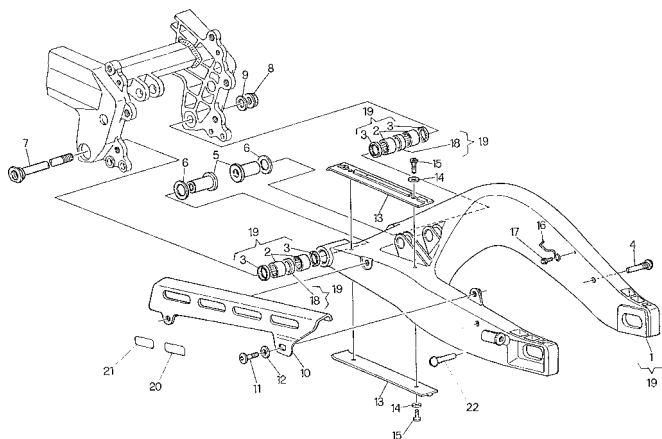
**17**

Pagina - Side - Page - Seite - Paja

**74**

Tavola - Drawing - Table - Bild - Tabla

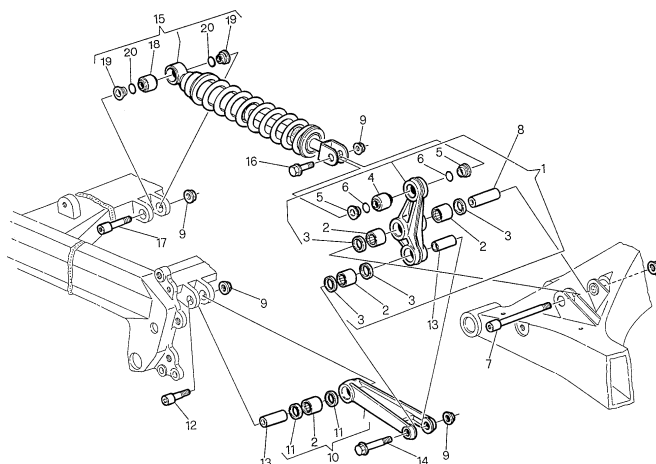
**18**

Pagina - Side - Page - Seite - Paja

**76**

Tavola - Drawing - Table - Bild - Tabla

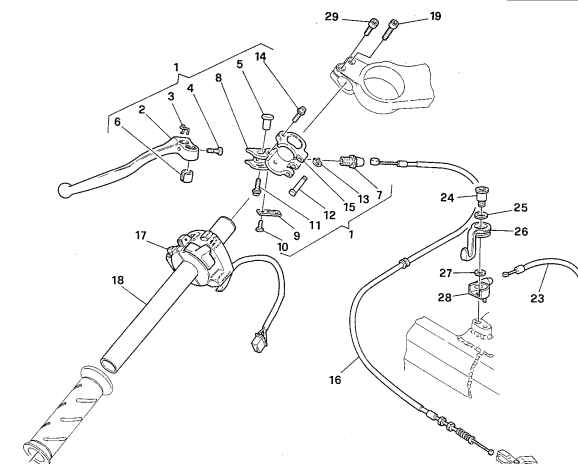
**19**

Pagina - Side - Page - Seite - Paja

**78**

Tavola - Drawing - Table - Bild - Tabla

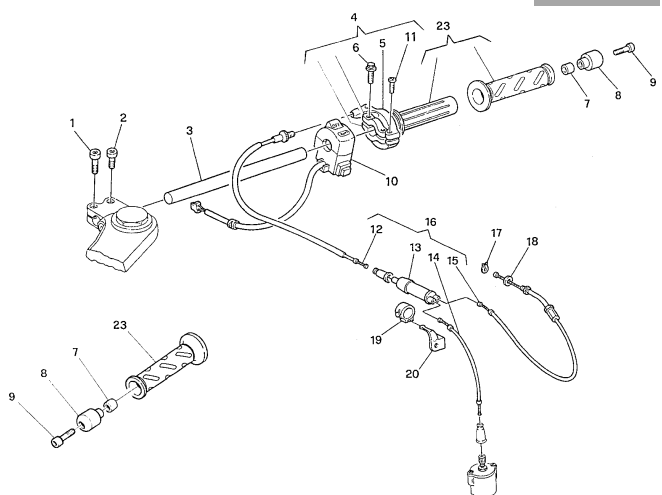
**20**

Pagina - Side - Page - Seite - Paja

**80**

Tavola - Drawing - Table - Bild - Tabla

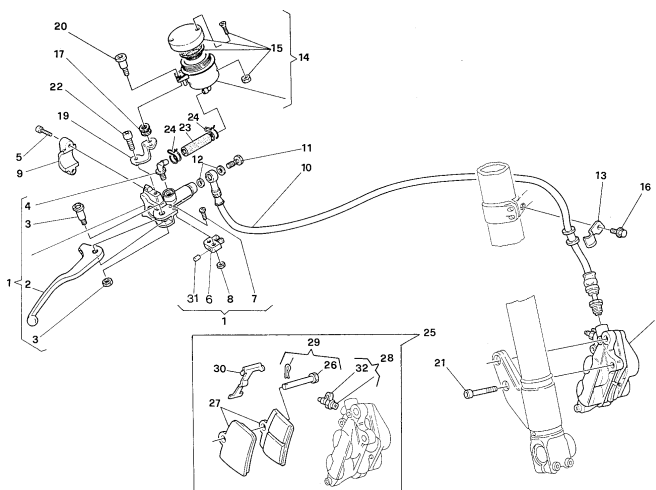
**21**

Pagina - Side - Page - Seite - Paja

**82**

Tavola - Drawing - Table - Bild - Tabla

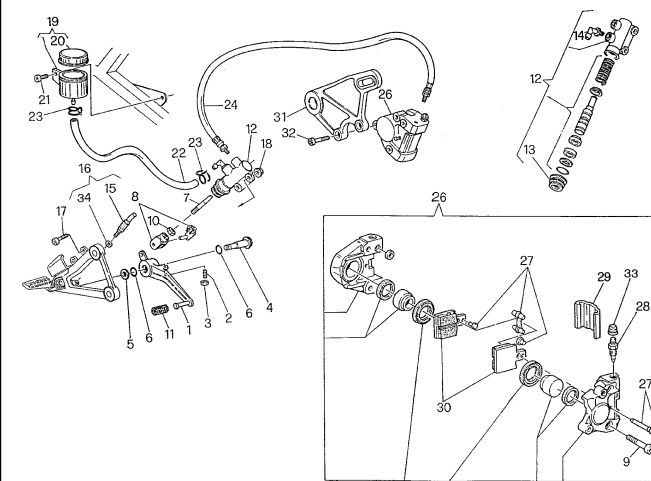
**22**

Pagina - Side - Page - Seite - Paja

**84**

Tavola - Drawing - Table - Bild - Tabla

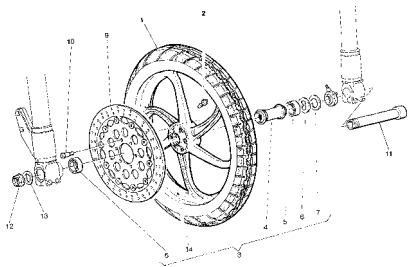
**23**

Pagina - Side - Page - Seite - Paja

**86**

Tavola - Drawing - Table - Bild - Tabla

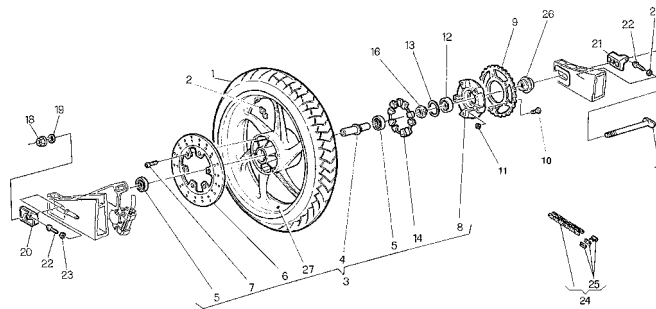
**24**

Pagina - Side - Page - Seite - Paja

**88**

Tavola - Drawing - Table - Bild - Tabla

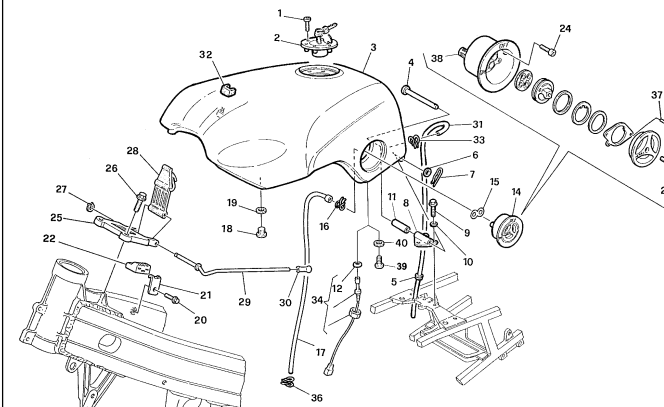
**25**

Pagina - Side - Page - Seite - Paja

**92**

Tavola - Drawing - Table - Bild - Tabla

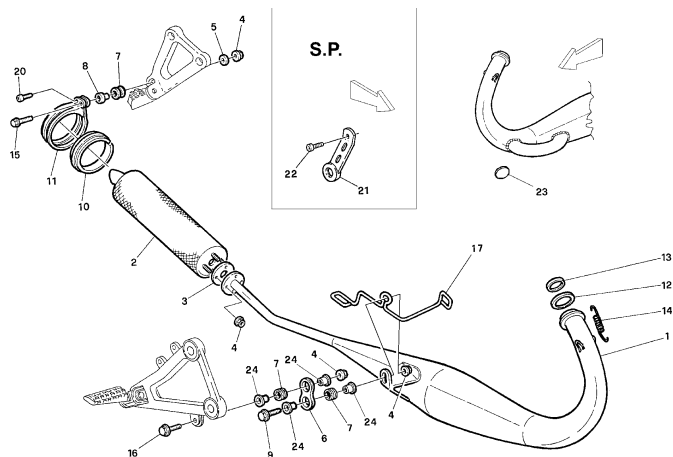
**26**

Pagina - Side - Page - Seite - Paja

**96**

Tavola - Drawing - Table - Bild - Tabla

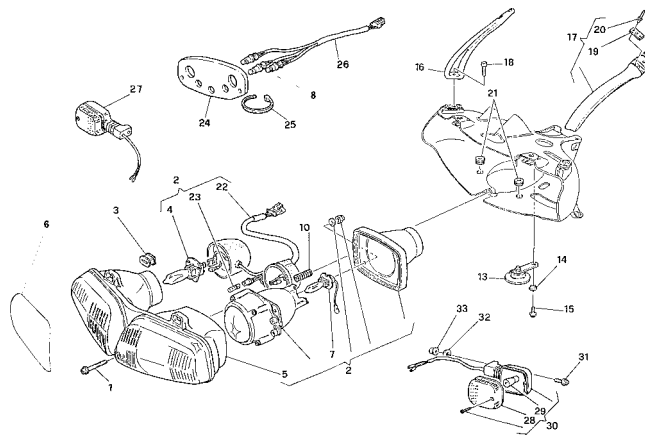
**27**

Pagina - Side - Page - Seite - Paja

**100**

Tavola - Drawing - Table - Bild - Tabla

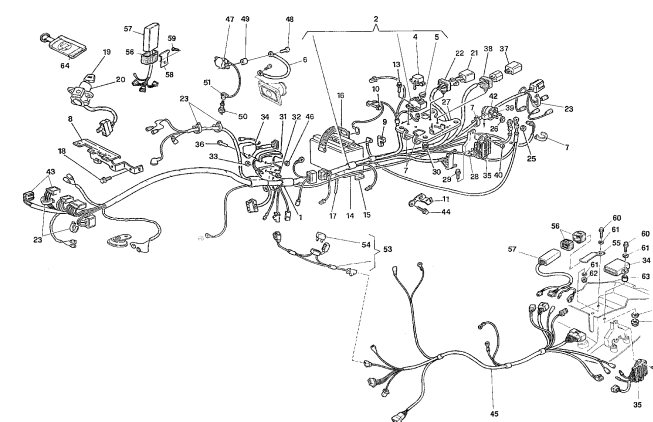
**28**

Pagina - Side - Page - Seite - Paja

**104**

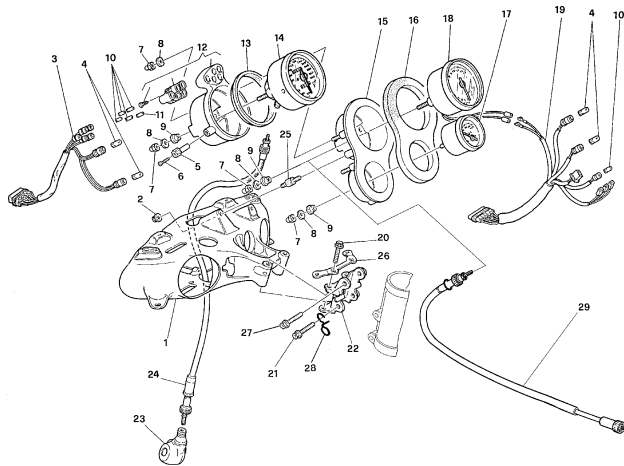

Tavola - Drawing - Table - Bild - Tabla

**29**

Pagina - Side - Page - Seite - Paja

**110**

Tavola - Drawing - Table - Bild - Tabla

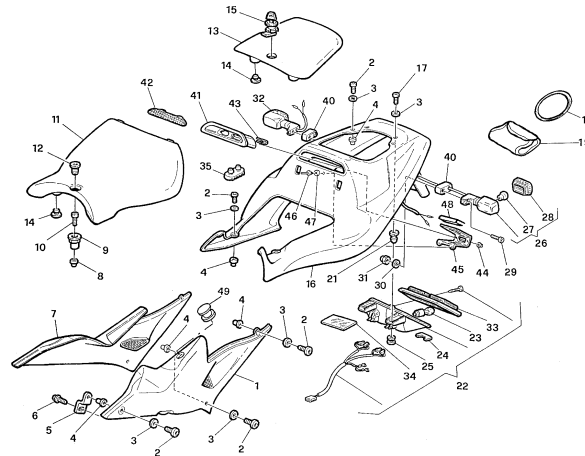
**30**

Pagina - Side - Page - Seite - Paja

**114**

Tavola - Drawing - Table - Bild - Tabla

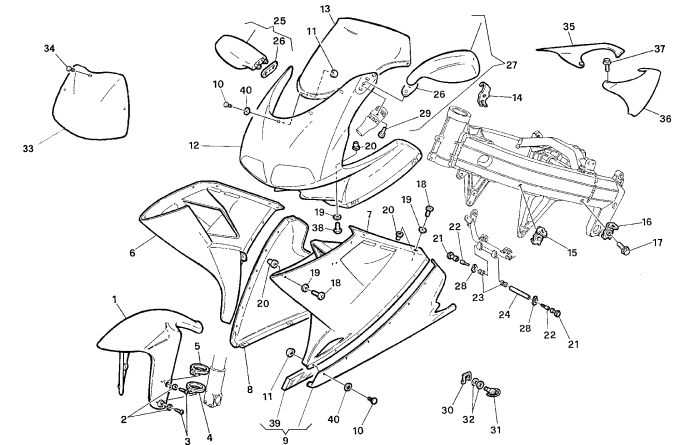
**31**

Pagina - Side - Page - Seite - Paja

**118**

Tavola - Drawing - Table - Bild - Tabla

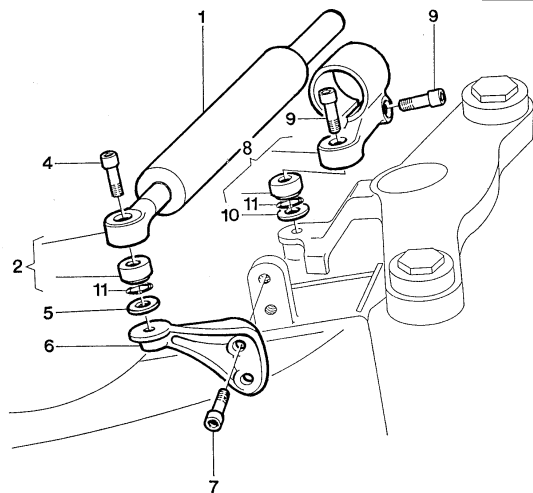
**32**

Pagina - Side - Page - Seite - Paja

**122**

Tavola - Drawing - Table - Bild - Tabla

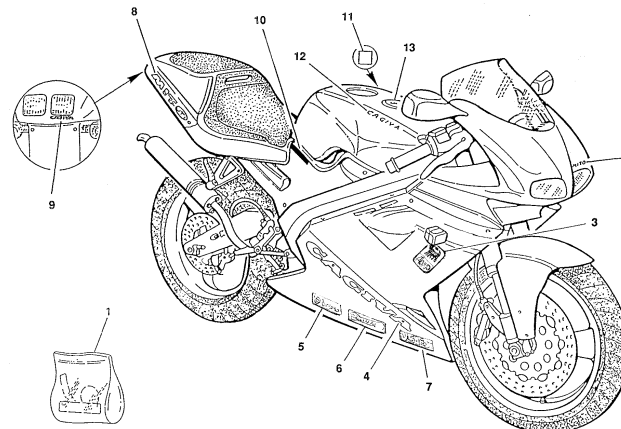
**33**

Pagina - Side - Page - Seite - Paja

**124**

Tavola - Drawing - Table - Bild - Tabla

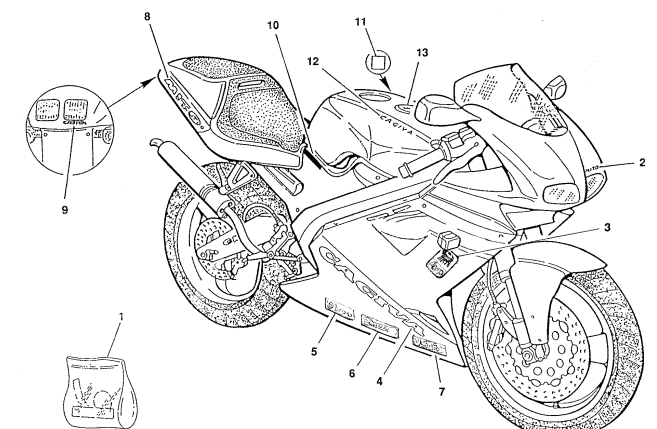
**33A**

Pagina - Side - Page - Seite - Paja

**126**

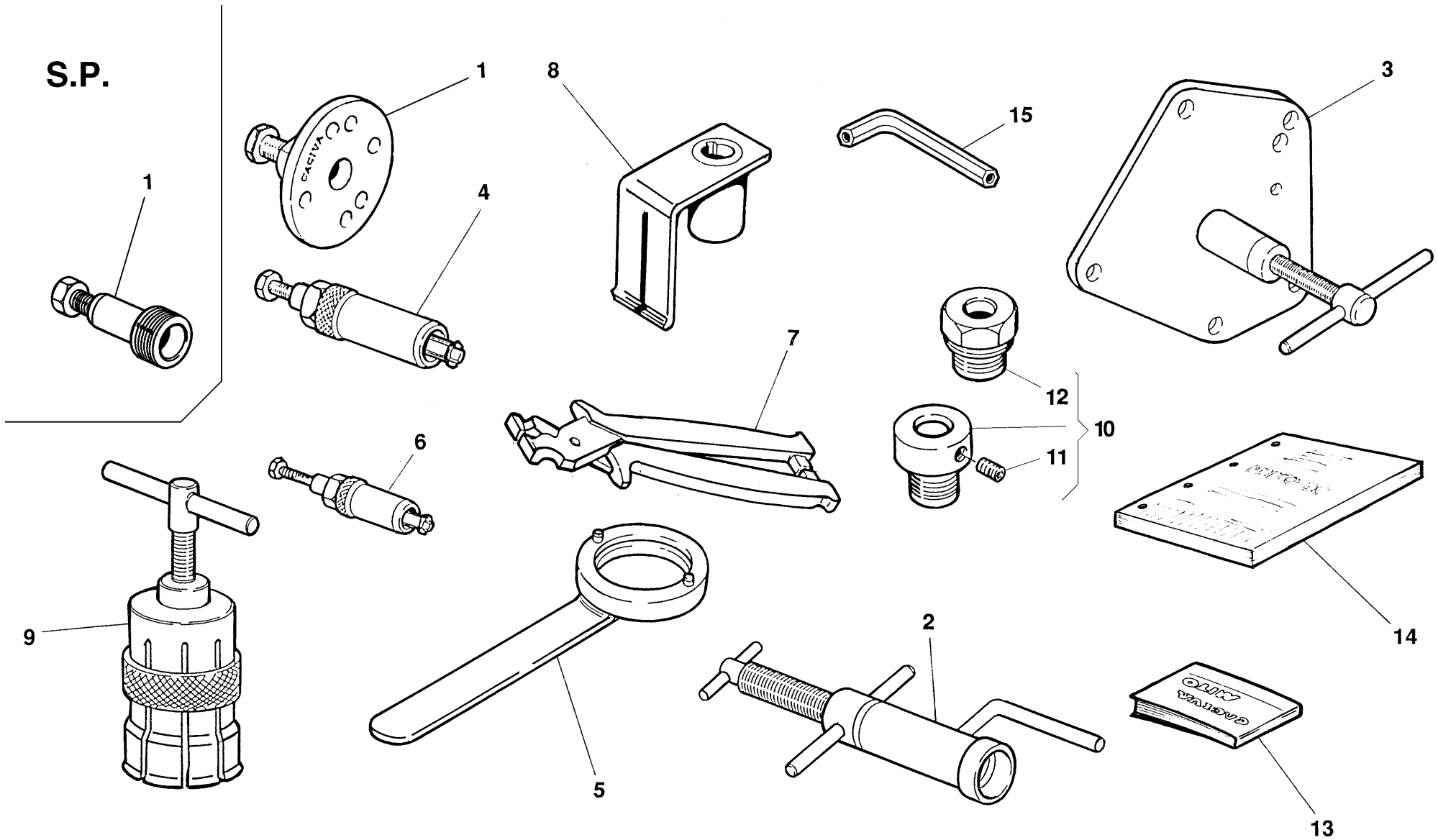

**ATTREZZI DI ASSISTENZA - SERVICE TOOLS  
OUTILS D'ASSISTANCE - HILFAUSRUSTUNG  
HERRAMIENTAS DE ASISTENCIA**

Note Notes Notas	Pos. No. Index Pos.	N. Cod. Code No. Nr. Code Code Nr N. Cod.	Q.tà Q.ty Q.te M.ge C.ad	DENOMINAZIONE	NAME	DESIGNATION	BESHREIBUNG	DENOMINACION	Validità Validity Validité Gültig Valides
	1	8000 51614	1	Estrattore volano	Flywheel extractor	Extracteur pour volant	Auszieher für Schwungrad	Extractor volante	
K	1	8000 46613	1	Estrattore volano	Flywheel extractor	Extracteur pour volant	Auszieher für Schwungrad	Extractor volante	
	2	8000 33047	1	Attrezzo montaggio albero motore nel carter dx.	Installing tool crankshft right	Outil mont. vilebrequin R. Gehäuse	Werkzeug zur Mont. Kurbelwelle im demicarter D.	Herram. mont. eje motore	
	3	8000 33048	1	Attrezzo sep. semicarter e smont. albero motore	Crankcase splitting tool and cranksheft disassembly	Outil pour demontage carters et vilebrequin	Werkzeug für Trennung Gehäusehälfte und Demontage Motorwelle	Herramienta semi-carter	
	4	8000 43823	1	Estrattore cuscinetto a rullini alb. primario e per anello di tenuta pompa acqua	Needle bearing main shaft and seal ring water pump	Extracteur pour roulement à aiguilles, arbre pri. arbre priet pour bague d'étachéité pompe à eau	Auszieher für Nadelkäfig Abtroebswelle un Wasserpump Manchette	Extractor coijnete de rodillos eje primario y para segmento de retención bomba agua	
	5	8000 46614	1	Chiave smont. per volano	Flywheel removing wrench	Cléf démontage volant	Demontierschlüssel für Schwungrad	Llave desmont. para volante	
	6	8000 33054	1	Estrattore cuscinetto a rullini albero pompa olio	Needle bearing oil pump shft extractor	Extrac. pour roulement arbre pompe à huile	Auszieher für Nadelkäfig Oelpumpenwelle	Extrac. cijnete de rodillos eje bomba aceite	
	7	8000 49767	1	Pinza montaggio fascette	Clamp installing plier	Pince pour montage collier	Schellenzange	Pinza montaje abrazaderas	
	8	8000 48803	1	Atrezzo controllo fase accens.	Ignition control tool	Outil pour surveillance allumage	Werkzeug zur Kontrolle der Zündung	Herramienta control fase encendido	
	9	000Y A2271	1	Estrattore per cuscinetto albero motore	Crankshaft bearing extractor	Extracteur pour roulement vilebrequin	Auszieher für Antriebswellelager	Extractor coijnete cigüeñal	
	10	8000 70582	1	Attrezzo P.M.S.	Tool	Outil	Werkzeug	Herramienta	
	11	8000 51521	1	Vite	Screw	Vis	Schraube	Tornillo	
	12	8000 70569	1	Supporto comparatore	Support	Support	Halterung	Soporte	
F	13	8A00 90500	1	Integrazione al libretto uso e manutenzione N°800090500	Supplement to the owner's manual nr.800090500	Supplément au livret d'emploi et d'entretien no.800090500	Ergänzung des Betriebsanleitung N.800090500	Integración al manual y mantenimiento n°800090500	
F	13	8000 90500	1	Libretto uso e manutenzione	Owner's manual	Emploi d'entretien	Betriebsanleitung	Manual y mantenimiento	
	14	8A00 93045	1	Integrazione della variante al manuale di officina n° 800093045	Supplement to the workshop's manual variant No. 800093045	Supplément a la variante au manuel de service Nr. 800093045	Ergänzung des Variante zum Werkstatthandbuch Nr. 800093045	Integración de la variante del manual de taller N. 800093045	
R	14	8000 93045	1	Variante al manuale di officina n° 800068543	Variant to the workshop manual No. 800068543	Variante au manuel d'atelier Nr. 800068543	Variante zu dem Werkstatthandbuch Nr. 800068543	Variante al manual de taller N. 800068543	
R	14	8000 68543	1	Manuale di officina	Workshop manual	Manuel d'atelier	Werkstatthandbuch	Manual de taller	

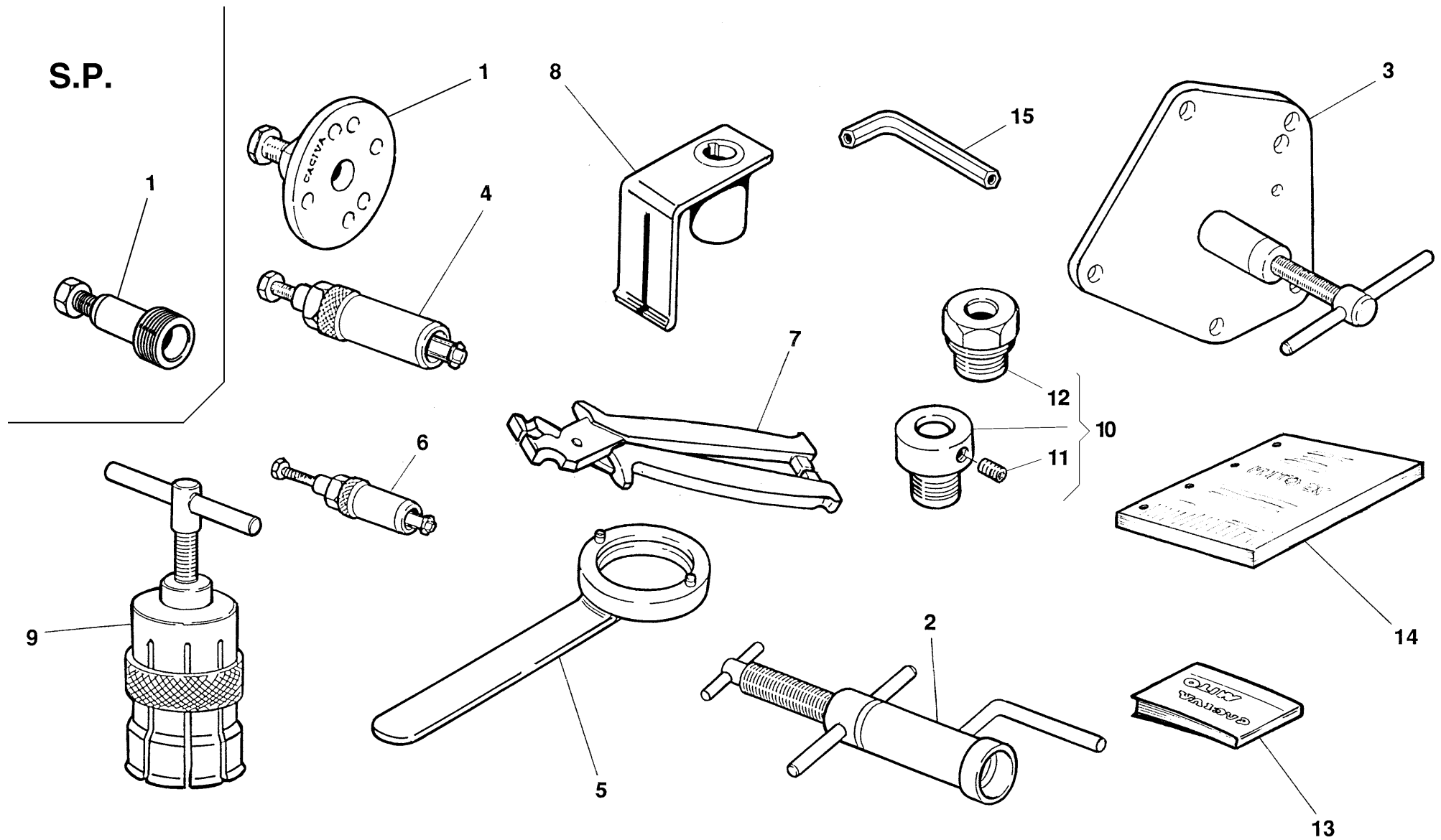

**ATTREZZI DI ASSISTENZA - SERVICE TOOLS  
 OUTILS D'ASSISTANCE - HILFAUSRUSTUNG  
 HERRAMIENTAS DE ASISTENCIA**

Note Notes Marke Notas	Pos. No. Index Pos.	N. Cod. Code No. Nr. Code Code Nr N. Cod.	Q.tà Q.ty Q.te M.ge C.ad	DENOMINAZIONE	NAME	DESIGNATION	BESHREIBUNG	DENOMINACION	Validità Validity Validité Gültig Valides
	15	8000 98431	1	Chiave per vite antimanomissione	Antitampering screw removing wrench	Cléf démontage vis anti manomission	Demontierschlüssel für Einbruchssicherschraube	Llave desmont. para tornillo antimanumisión	
R				A richiesta	Up on request	Sur demande	Auf Anfrage	Bajo pedido	
F				Fornire assieme	Supply unitely	Fournir ensemble	Wird zusammen geliefert	Equipar juntos	
K				A richiesta per kit S.P. '99 cod. 800092789	Up on request for S.P. kit '99 code 800092789	Sur demande pour set S.P. '99 code 800092789	Auf Anfrage für Kit S.P. '99 Code 800092789	Bajo pedido por kit S.P. '99 cod. 800092789	

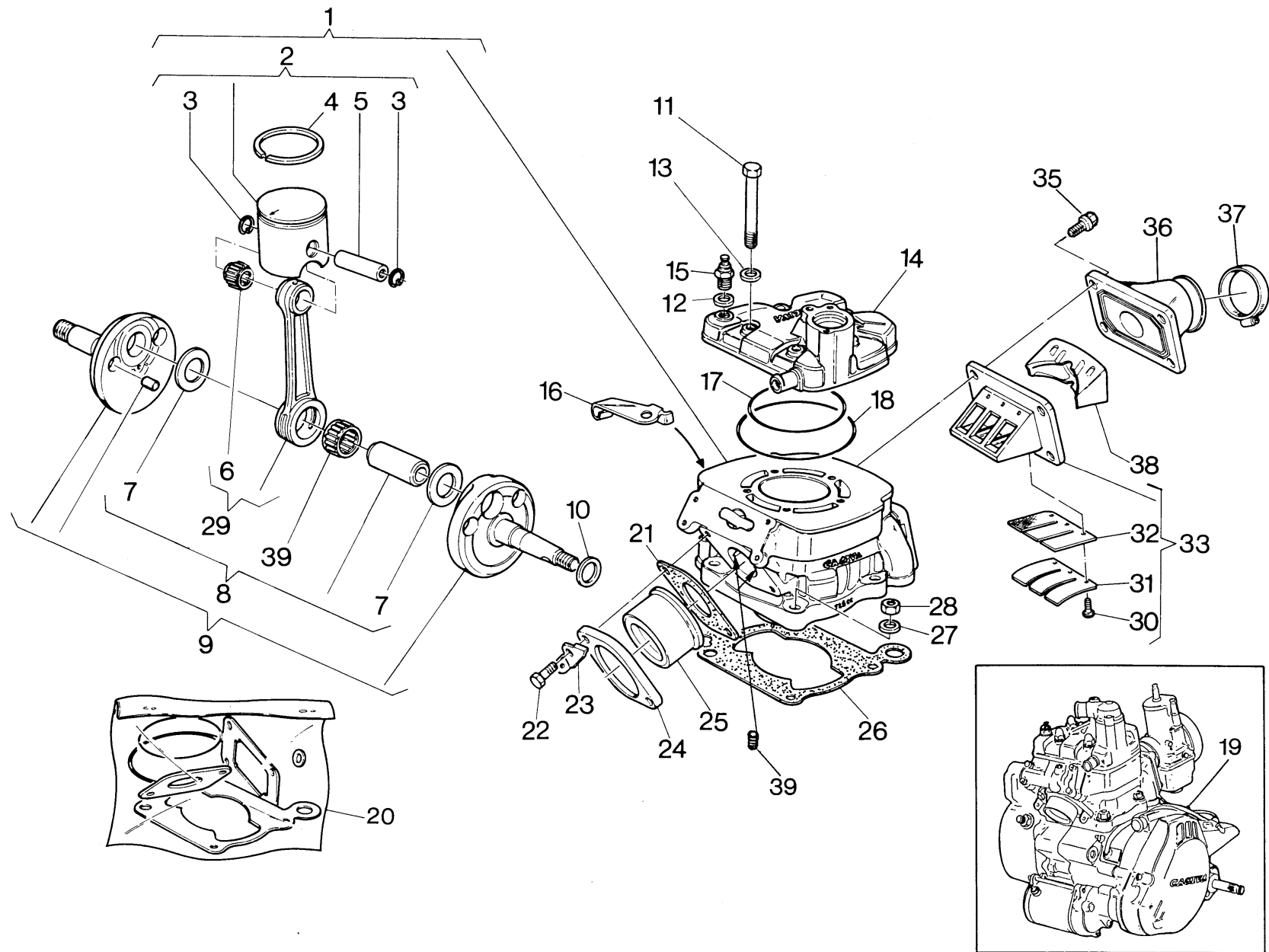

**TESTA, CILINDRO, PISTONE, MANOVELLISMO - CYLINDER HEAD, CYLINDER, PISTON, CRANKSHAFT  
CULASSE, CYLINDRE, PISTON, VILEBREQUIN - ZYLINDERKOPF, ZYLINDER, KOLBEN, KURBELWELLE  
CULATA, CILINDRO, PISTON, PALANCAS**

Note Notes Marke Notas	Pos. No. N. Index Pos.	N. Cod. Code No. Nr. Code Code Nr. N. Cod.	Q.tà Q.ty Q.te M.ge C.ad	DENOMINAZIONE	NAME	DESIGNATION	BESHREIBUNG	DENOMINACION	Validità Validity Validité Gültig Valides
	1	8000 A0400	1	Ass. cilindro completo	Cylinder assy	Cylindre compl.	Zylinder kpl.	Cilindro compl.	
K	1	8000 90206	1	Ass. cilindro completo	Cylinder assy	Cylindre compl.	Zylinder kpl.	Cilindro compl.	
Z	1	8000 97741	1	Ass. cilindro completo	Cylinder assy	Cylindre compl.	Zylinder kpl.	Cilindro compl.	
	2	8000 A0402	1	Ass. pistone A ø 55,96÷55,97	Piston assy	Piston compl.	Kolben kpl.	Pistón	
	2	8000 A0402	1	Ass. pistone B ø 55,97÷55,98	Piston assy	Piston compl.	Kolben kpl.	Pistón	
	2	8000 A0402	1	Ass. pistone C ø 55,98÷55,99	Piston assy	Piston compl.	Kolben kpl.	Pistón	
KZ	2	8000 96963/1	1	Ass. pistone A ø 55,943÷55,957	Piston assy	Piston compl.	Kolben kpl.	Pistón	
KZ	2	8000 96963/2	1	Ass. pistone B ø 55,953÷55,967	Piston assy	Piston compl.	Kolben kpl.	Pistón	
KZ	2	8000 96963/3	1	Ass. pistone C ø 55,963÷55,977	Piston assy	Piston compl.	Kolben kpl.	Pistón	
	3	8000 34358	2	Anellino	Ring	Bague	Ring	Anillo	
	4	8000 48381	2	Segmento	Piston ring	Segment	Kolbenring	Segmento	
KZ	4	8000 91877	1	Segmento	Piston ring	Segment	Kolbenring	Segmento	
	5	8000 37343	1	Spinotto	Pin	Gudgeon	Bolzen	Perno	
K	5	8000 81984	1	Spinotto	Pin	Gudgeon	Bolzen	Perno	
H	6	8000 21929	1	Cuscinetto per piede di biella	Needle bearing for small en rod	Roul. à aiguil. pour pied de biel.	Nadelkäfig fur Pleuelauge	Col. para cuello de biella	
KH	6	8000 92243	1	Cuscinetto per piede di biella gioco 0 ÷ -0,002	Needle bearing for small en rod clearance 0 ÷ -0,002	Roul. à aiguil. pour pied de biel. jeu 0 ÷ -0,002	Nadelkäfig fur Pleuelauge Spiel 0 ÷ -0,002	Col. para cuello de biella juego 0 ÷ -0,002	
KH	6	8000 94105	1	Cuscinetto per piede di biella gioco -0,002 ÷ -0,004	Needle bearing for small en rod clearance -0,002 ÷ -0,004	Roul. à aiguil. pour pied de biel. jeu -0,002 ÷ -0,004	Nadelkäfig fur Pleuelauge Spiel -0,002 ÷ -0,004	Col. para cuello de biella juego -0,002 ÷ -0,004	
	7	8000 32231	2	Rondella	Washer	Rondelle	Scheibe	Arandela	
	8	8000 54884	1	Biella motore completa	Connecting rod compl.	Bielle compl.	Pleuelstange kpl.	Biela motor completa	
	9	8000 54882	1	Assieme albero motore	Crankshaft assy	Vilebrequin compl.	Kurbewelle kpl.	Juego eje motor	
Z	9	8000 97584	1	Assieme albero motore	Crankshaft assy	Vilebrequin compl.	Kurbewelle kpl.	Juego eje motor	
	10	8A00 10350	1	Rosetta di ras. sp. 0,3 mm.	Washer	Rondelle	Scheibe	Arandela	
	10	8B00 10350	1	Rosetta di ras. sp. 0,4 mm.	Washer	Rondelle	Scheibe	Arandela	
	10	8C00 10350	1	Rosetta di ras. sp. 0,5 mm.	Washer	Rondelle	Scheibe	Arandela	
	10	8D00 10350	1	Rosetta di ras. sp. 0,6 mm.	Washer	Rondelle	Scheibe	Arandela	
	11	8000 62796	5	Vite	Screw	Vis	Schraube	Tornillo	
	12	62N0 15676	1	Rosetta	Washer	Rondelle	Scheibe	Arandela	
	13	8000 39335	5	Rosetta	Washer	Rondelle	Scheibe	Arandela	
	14	80A0 64818	1	Testa motore	Cylinder head	Culasse	Zylinderkopf.	Culata	
K	14	8000 81785	1	Testa motore	Cylinder head	Culasse	Zylinderkopf.	Culata	
Z	14	8000 96884	1	Testa motore	Cylinder head	Culasse	Zylinderkopf.	Culata	

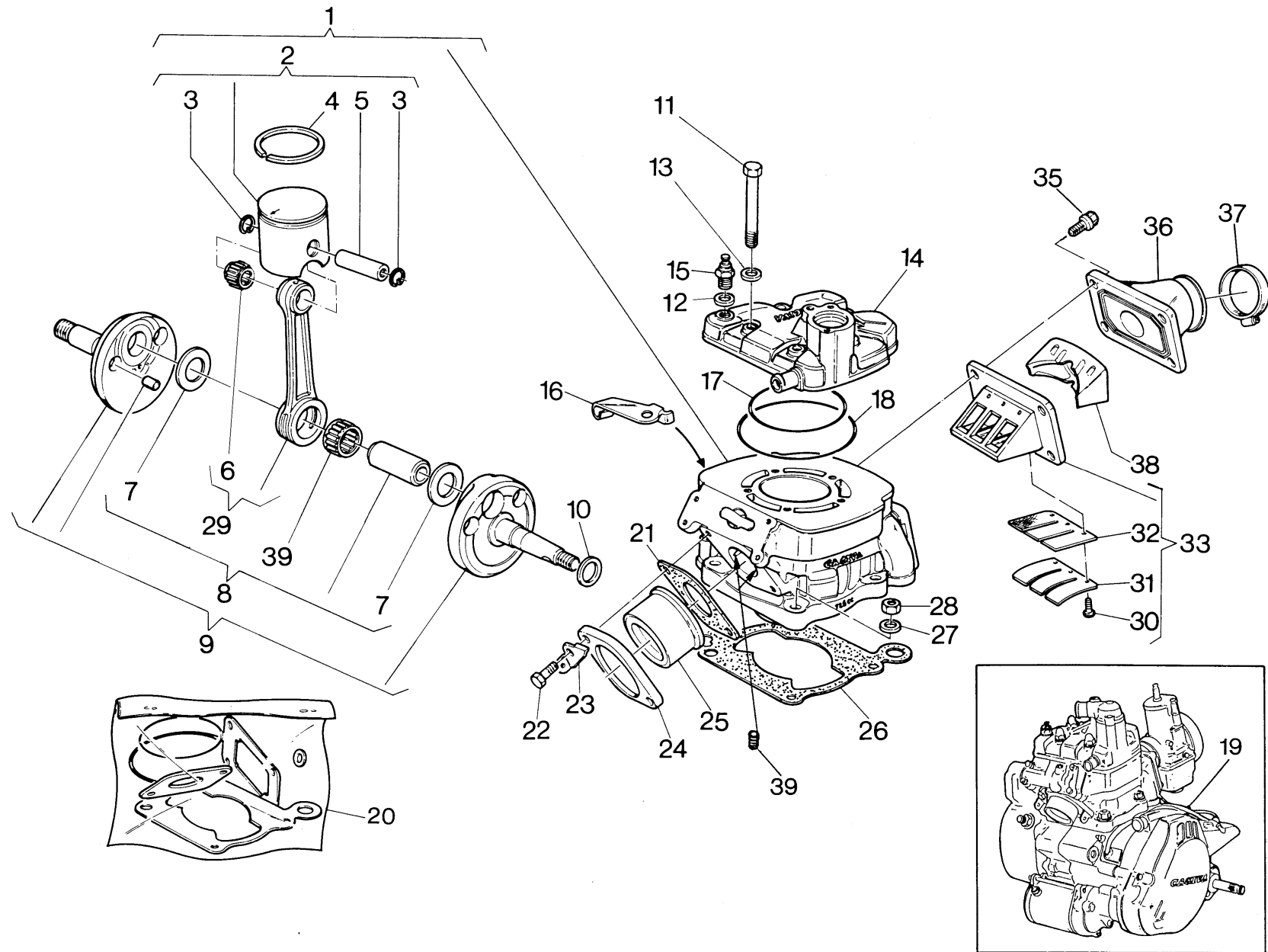



**TESTA, CILINDRO, PISTONE, MANOVELLISMO - CYLINDER HEAD, CYLINDER, PISTON, CRANKSHAFT  
CULASSE, CYLINDRE, PISTON, VILEBREQUIN - ZYLINDERKOPF, ZYLINDER, KOLBEN, KURBELWELLE  
CULATA, CILINDRO, PISTON, PALANCAS**

Note Notes Marke Notas	Pos. No. Index Pos.	N. Cod. Code No. Nr. Code Code Nr N. Cod.	Q.tà Q.ty Q.te M.ge C.ad	DENOMINAZIONE	NAME	DESIGNATION	BESHREIBUNG	DENOMINACION	Validità Validity Validité Gültig Valides
	15	8000 53249	1	Termistore per testa	Thermistor	Thermistor	Thermistor	Thermistor	
	16	8000 67501	1	Piastrina	Plate	Plaquette	Plättchen	Placa	
	17	8000 38203	1	Guarnizione OR int. per testa	OR Gasket	Garniture "O"	O Ring Dichtung	Junta OR	
	18	8000 47707	1	Guarnizione OR est. per testa	OR Gasket	Garniture "O"	O Ring Dichtung	Junata OR	
	19	8000 A1055	1	Assieme motore	Engine assy	Moteur complet	Motor kpl.	Motor compl.	
	21	8000 30856	1	Guarnizione per flangia	Gasket	Garniture	Dichtung	Junta	
K	21	8000 90203	1	Guarnizione per flangia	Gasket	Garniture	Dichtung	Junta	
Z	21	8000 97949	1	Guarnizione per flangia	Gasket	Garniture	Dichtung	Junta	
	22	60N1 01082	2	Vite fiss. raccordo	Screw	Vis	Schraube	Tornillo	
Z	22	8000 62729	2	Vite fiss. raccordo	Screw	Vis	Schraube	Tornillo	
	23	8000 57165	2	Piastrina	Plate	Plaquette	Plättchen	Placa	
	24	8000 46592	1	Flangia	Flange	Bride	Flansch	Brida	
	25	8A00 46627	1	Raccordo	Union	Raccord	Anschluss	Empalme	
K	25	8000 90202	1	Raccordo	Union	Raccord	Anschluss	Empalme	
Z	25	8000 97950	1	Raccordo	Union	Raccord	Anschluss	Empalme	
KZ	26	8000 49557	1	Guarnizione sp. 0,2	Gasket	Garniture	Dichtung	Junta	
	26	8A00 49557	1	Guarnizione sp. 0,3	Gasket	Garniture	Dichtung	Junta	
	26	8B00 49557	1	Guarnizione sp. 0,4	Gasket	Garniture	Dichtung	Junta	
	26	8C00 49557	1	Guarnizione sp. 0,5	Gasket	Garniture	Dichtung	Junta	
	26	8D00 49557	1	Guarnizione sp. 0,6	Gasket	Garniture	Dichtung	Junta	
	26	8E00 49557	1	Guarnizione sp. 0,7	Gasket	Garniture	Dichtung	Junta	
	27	8000 11276	4	Rosetta	Washer	Rondelle	Scheibe	Arandela	
	28	8000 17810	4	Dado fiss. cilindro	Nut	Ecrou	Mutter	Tuerca	
R	29	8000 92242	1	Biella con gabbia al piede	Connecting rod with small end needle bearing	Bielle avec roulement à aiguille pour pied de bielle	Pleuelstange mit Nadelkäfig	Biela motor con cojnete para cuello	
Z	29	8000 97585	1	Biella con gabbia al piede	Connecting rod with small end needle bearing	Bielle avec roulement à aiguille pour pied de bielle	Pleuelstange mit Nadelkäfig	Biela motor con cojnete para cuello	
	30	8000 61102	8	Vite	Screw	Vis	Schraube	Tornillo	
	31	8000 69171	2	Piastrina	Plate	Plaquette	Plättchen	Placa	
	32	8000 67576	2	Lamella	Plate	Lamelle	Plättchen	Laminilla	
KZ	32	8B00 67576	2	Lamella	Plate	Lamelle	Plättchen	Laminilla	
	33	8000 69172	1	Valvola aspirazione compl.	Inlet valve	Soupape admission	Einlass Ventil	Válvula aspiración	
	35	8000 98213	4	Vite antimanomissione	Antitampering screw	Vis antimanomission	Einbruchssicherschraube	Tornillo antimanumisión	

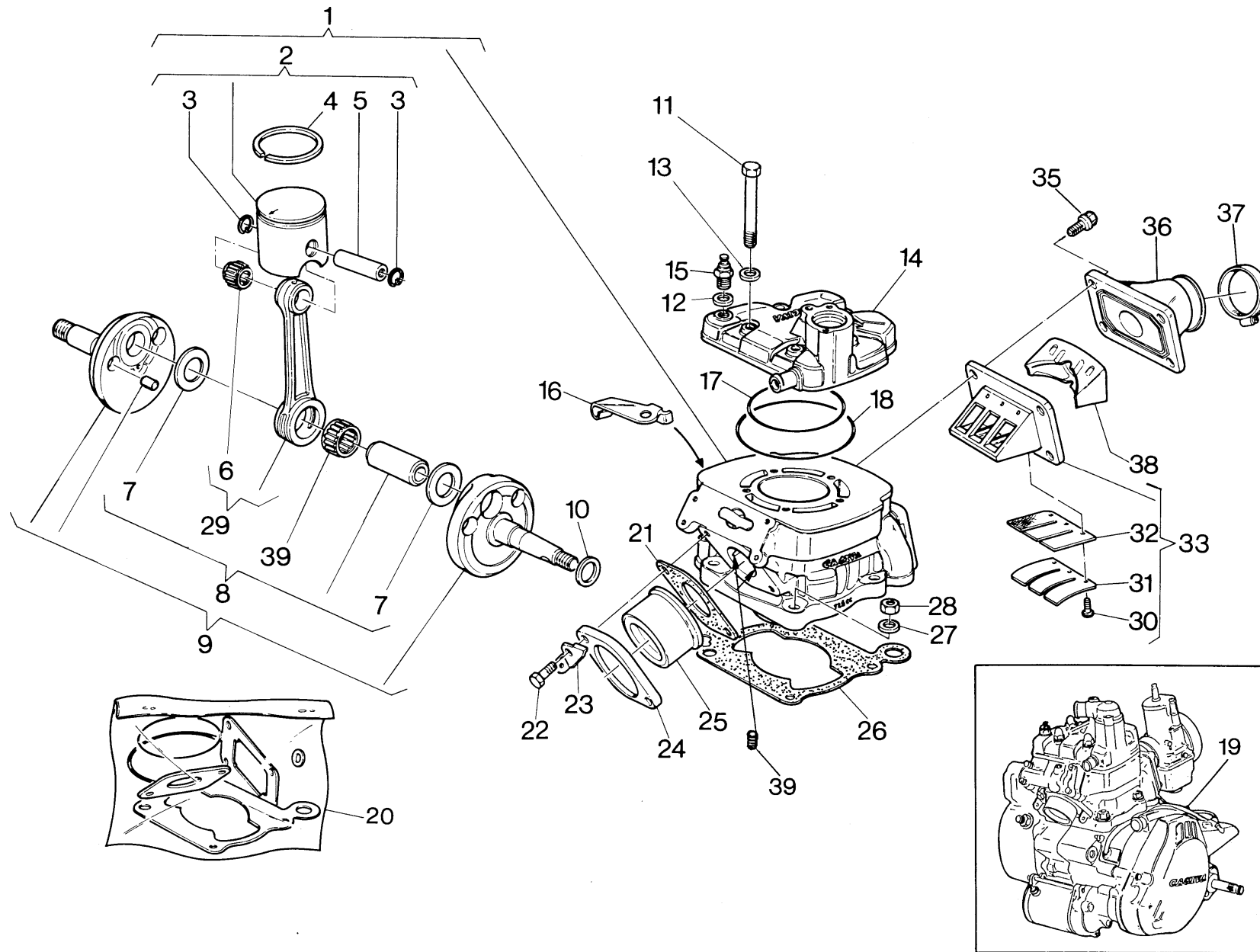

Note Notes Marke Notas	Pos. No. Index Pos.	N. Cod. Code No. Nr. Code Code Nr N. Cod.	Q.tà Q.ty Q.te M.ge C.ad	DENOMINAZIONE	NAME	DESIGNATION	BESHREIBUNG	DENOMINACION	Validità Validity Validité Gültig Valides
	36	8000 72633	1	Raccordo	Union	Raccord	Anschluss	Empalme	
	37	7415 0441B	1	Fascetta	Clamp	Collier	Schelle	Banda	
	38	8000 65302	1	Inserto	Inlet	Piece	Einlass	Inserto	
Z	39	8000 97583	1	Cuscinetto per testa di biella gioco 0 ÷ -0,002	Needle bearing for big end rod clearance 0 ÷ -0,002	Roul. à aiguil. pour tête de biel. jeu 0 ÷ -0,002	Pleuelstangenkopflager Spiel 0 ÷ -0,002	Col. para cabeza de biela juego 0 ÷ -0,002	
A				In alternativa	In alternative	En alternative	Wahlweise	En alternativa	
H				Accoppiamento piede biella	Connec.road small end coupl.	Couplage de pied de bielle	Verbindung despleuelstangenk.	Acoplamiento pie de biela	
K				A richiesta per kit S.P. '99 cod. 800092789	Upon request for S.P. kit '99 code 800092789	Sur demande pour set S.P. '99 code 800092789	Auf Anfrage für Kit S.P. '99 Code 800092789	Bajo pedido por kit S.P. '99 cod. 800092789	
Z				A richiesta per kit S.P. '01 cod. 800097946	Upon request for S.P. kit '01 code 800097946	Sur demande pour set S.P. '01 code 800092789	Auf Anfrage für Kit S.P. '01 Code 800097946	Bajo pedido por kit S.P. '01 cod. 800097946	

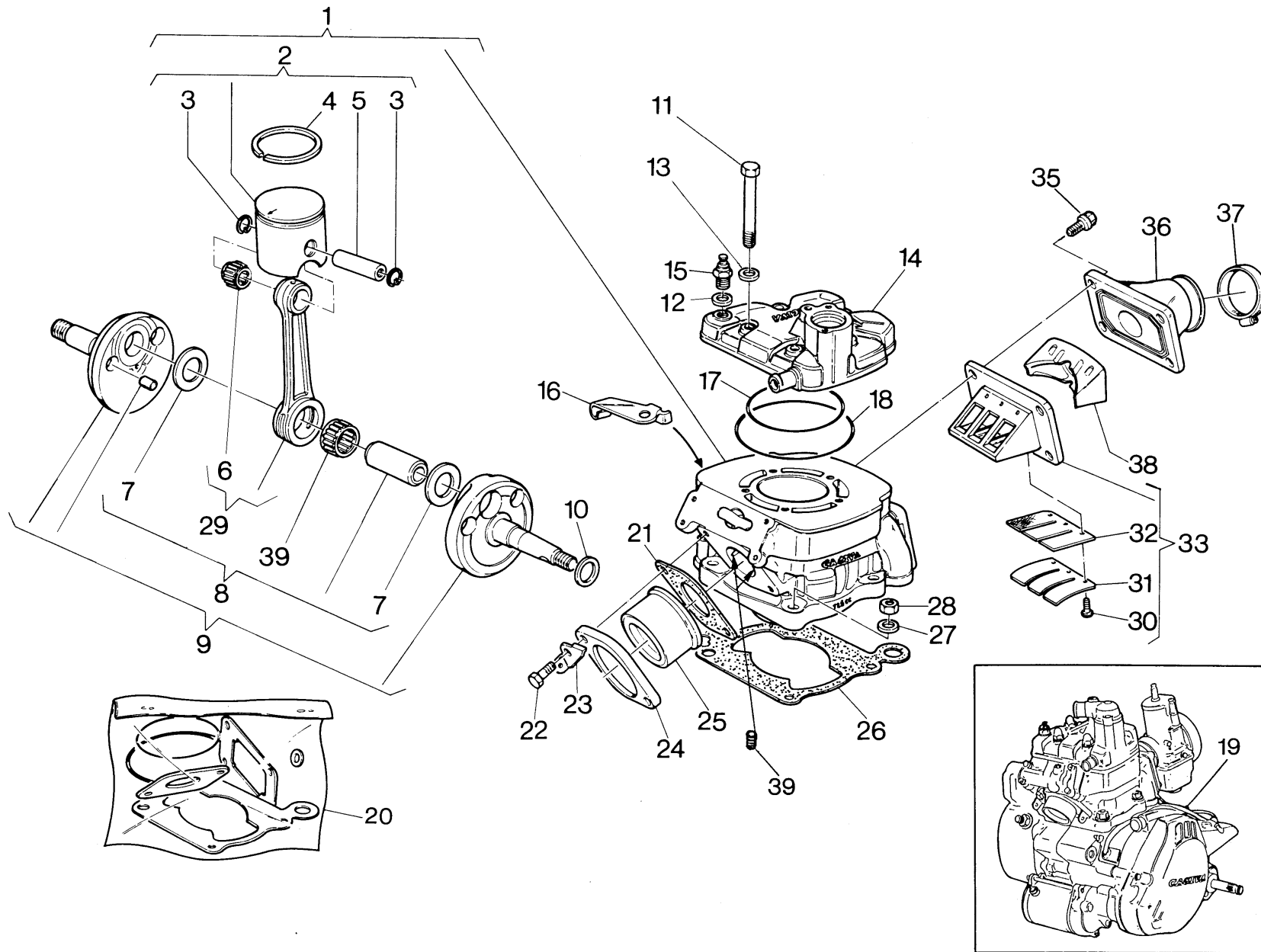

La sottoriportata tabella elenca i possibili accoppiamenti che consentono di ottenere il corretto gioco radiale di 0,002÷0,010 mm

The table hereunder shows the possible coupling which allow to obtain a radial clearance of 0.002÷0.010 mm

Le tableau ci-dessous indique tous les couplages possibles permettant d'obtenir le jeu radial exact de 0,002÷0,010 mm

Die folgende Tabelle gibt die möglichen Verbindungen an für das genaue Radialspiel von 0,002÷0,010 mm

La tabla que se da a continuación lista los acoplamientos posibles que permiten obtener el juego radial correcto de 0,002÷0,010 mm

C: colore di selezione biella

C: rod selection colour

C: couleur de sélection bielle

C: Wahlfarbe der Pleuelstange

C: color de selección biela

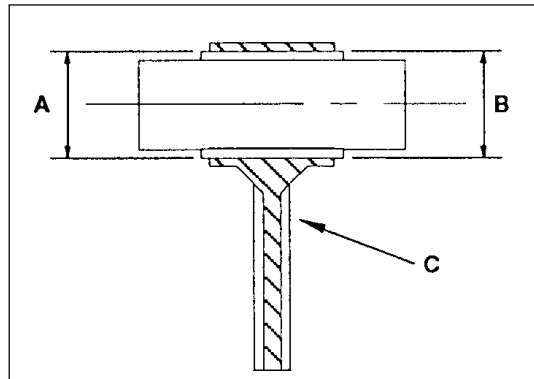

Colore di selezione foro «A» piede di biella (mm) Hole selection colour «A» connecting rod small end (mm) Couleur de sélection trou «A» pied de bielle (mm) Wahlfarbe der Bohrung «A» Pleuelstangenkopf (mm) Color de selección «A» pie de biela (mm)	Selezione gabbia a rullini «B» µm Cage selection «B» µm Sélection cage à rouleaux «B» µm Wahlnadelkäfig «B» µm Selección jaula de agujas «B» µm
Giallo - Yellow - Jaune - Gelb - Amarillo 19,994 ÷ 19,996	- 3 ÷ - 5
Verde - Green - Vert - Grün - Verde 19,996 ÷ 19,998	- 3 ÷ - 5
Bianco - White - Blanc - Weiss - Blanco 19,998 ÷ 20,000	- 1 ÷ - 3 - 2 ÷ - 4
Nero - Black - Noir - Schwarz - Negro 20,000 ÷ 20,002	0 ÷ - 2 - 1 ÷ - 3
Rosso - Red - Rouge - Rot - Rojo 20,002 ÷ 20,004	0 ÷ - 2

Qualora, in sede di revisione del motore, si dovesse riscontrare un gioco radiale superiore al limite ammesso di 0,015 mm e non fosse più visibile il contrassegno del colore sullo stelo della biella, rilevare il diametro «A» del piede di biella e, in base a questo, montare la gabbietta appropriata.

When overhauling, should a radial clearance greater than the consented limit of 0.015 mm be noticed and the colour mark under the connecting rod small end is no more visible, collect the connecting rod small end «A» diameter and assemble the right cage according to it.

Si en révisonnant le moteur on trouve un jeu radial supérieur à la limite admise de 0,015 mm et le marque de la couleur n'est plus visible sur la tige de bielle, enregistrer le diamètre «A» du pied de bielle et assembler la cage exacte selon ce diamètre.

Falls bei Motorprüfung das Radialspiel über das zugelassene Mass von 0,015 mm sein sollte und das Farbkennzeichen an der Pleuelstange nicht mehr sichtbar ist, wird der «A»-Durchmesser des Pleuelstangenkopfes gemessen und aufgrund dessen der geeignete Käfig montiert..

En el caso que, cuando inspeccione el motor, encuentre un juego radial superior al límite admitido de 0,015 mm y no resultara más visible la señalización del color en el vástago de la biela, registre el diámetro «A» del piede biela y, sobre la base de este dato, monte la jaula adecuada.

NOTA: Nel richiedere la gabbia a rullini, specificare la selezione.

NOTE: When requesting the cage, specify the selection.

NOTA: En demandant la cage à rouleaux, spécifier la sélection.

BEMERKUNG: Bei Anfrage den genauen Wahlnadelkäfig angeben.

NOTA: cuando pida la jaula de agujas, especifique la selección.

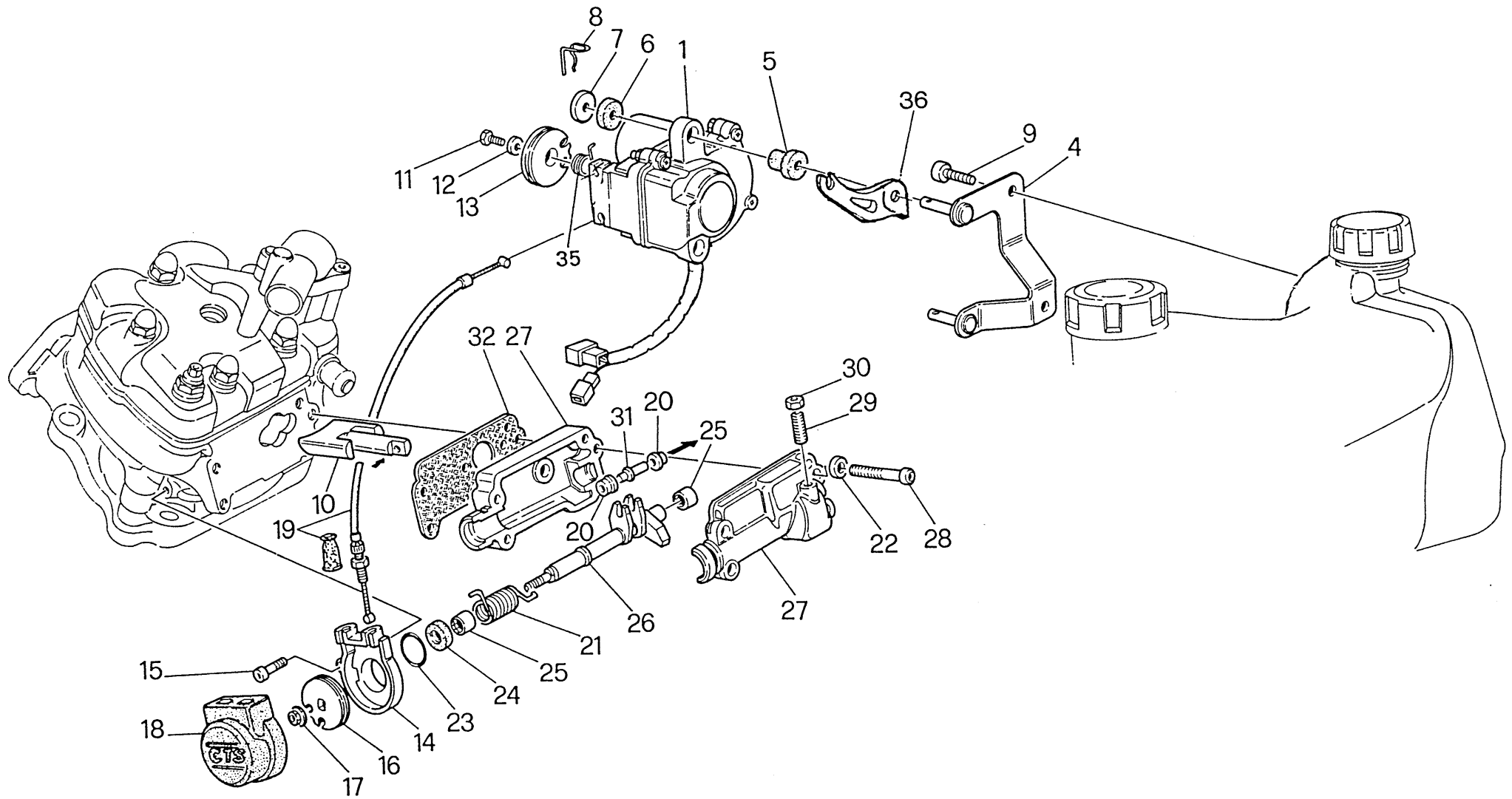

Note Notes Notas	Pos. No. Index Pos.	N. Cod. Code No. Nr. Code Code Nr N. Cod.	Q.tà Q.ty Q.te M.ge C.ad	DENOMINAZIONE	NAME	DESIGNATION	BESHREIBUNG	DENOMINACION	Validità Validity Validité Gültig Valides
	1	8000 59034	1	Attuatore	Actuator	Actionneur	Trieb	Actuador	
	4	8000 67943	1	Supporto	Support	Support	Halterung	Soporte	
	5	8000 59287	2	Antivibrante	Silent block	Antivibration	Schwingungsdämpfer	Anti vibrador	
	6	8000 62390	2	Rosetta in gomma	Rubber washer	Rondella en caoutchouc	Gummischeibe	Roseta de goma	
	7	8000 39260	2	Rosetta piana	Washer	Rondelle	Scheibe	Arandela	
	8	8000 62705	2	Molletta	Spring	Ressort	Feder	Resorte	
	9	8000 62725	2	Vite	Screw	Vis	Schraube	Tornillo	
	10	8A00 67781	1	Valvola di scarico	Exhaust valve	Soupape d'échappement	Auslass Ventil	Válvula de escape	
	11	60N1 01050	1	Vite	Screw	Vis	Schraube	Tornillo	
	12	60N1 15766	1	Rosetta elastica	Spring washer	Rondelle élastique	Federscheibe	Arandela elástica	
	13	8000 66204	1	Carrucola	Pulley	Poulie	Führungsrolle	Polea	
	14	8000 54894	1	Basetta	Button strip	Base poussoirs	Druckknopf tafel	Placa	
	15	60N1 07330	1	Vite	Screw	Vis	Schraube	Tornillo	
	16	8000 54896	1	Carrucola	Pulley	Poulie	Führungsrolle	Polea	
	17	8000 42278	1	Dado	Nut	Ecrou	Mutter	Tuerca	
	18	8000 54893	1	Coperchio	Cover	Couvercle	Deckel	Tapa	
	19	8000 58865	2	Trasmissione comando valvola	Throttle wire	Fil comm. gaz	Gaszugkabel	Trasmisión acc. acelerador	
	20	8000 58048	2	Rotella	Wheel	Galet	Rädchen	Ruedecilla	
	21	8000 54696	1	Molla	Spring	Ressort	Feder	Resorte	
	22	62N1 15503	4	Rosetta	Washer	Rondelle	Scheibe	Arandela	
	23	8000 36380	1	Anello di tenuta	Seal ring	Bague d'étanchéité	Dichtungsring	Anillo de retención	
	24	8000 64296	1	Anello di tenuta	Seal ring	Bague d'étanchéité	Dichtungsring	Anillo de retención	
	25	8000 31748	2	Cuscinetto a rullini	Needle bearing	Roulement à aiguilles	Nadelkäfig	Cojinete	
	26	8000 60430	1	Perno	Pin	Pivot	Bolzen	Perno	
	27	8000 58861	1	Ass. supp. e coperchio	Support and cover assy	Support et couvercle compl.	Kpl. Halter und Deckel	Soporte y tapa compl.	
	28	60N1 02489	4	Vite	Screw	Vis	Schraube	Tornillo	
	29	8000 49917	1	Vite	Screw	Vis	Schraube	Tornillo	
	30	61N1 15151	1	Dado	Nut	Ecrou	Mutter	Tuerca	
	31	8000 58046	1	Perno	Pin	Pivot	Bolzen	Perno	
	32	8000 47716	1	Guarnizione	Gasket	Garnitue	Dichtung	Junta	
	35	8000 76984	1	Molla attuatore	Sring	Ressort	Feder	Resorte	
	36	8000 78179	1	Supporto	Support	Support	Halterung	Soporte	

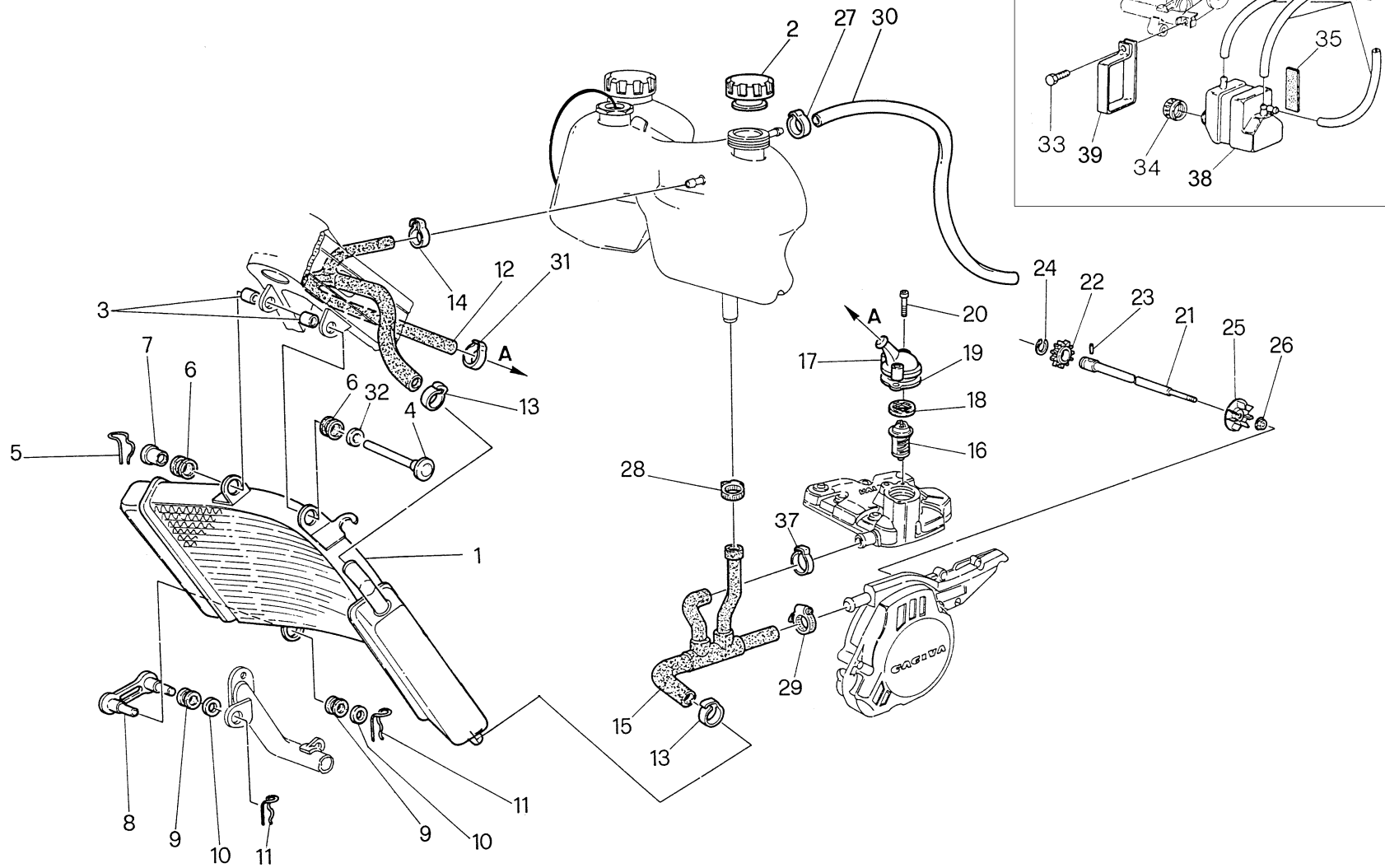



Note Notes Notas	Pos. No. Index Pos.	N. Cod. Code No. Nr. Code N. Cod.	Q.tà Q.ty Q.te M.ge C.ad	DENOMINAZIONE	NAME	DESIGNATION	BESHREIBUNG	DENOMINACION	Validità Validity Validité Gültig Valides
	1	80A0 66501	1	Radiatore	Radiator	Radiateur	Kühler	Radiador	
	2	8931 0041A	1	Tappo	Plug	Bouchon	Verschluss	Tapón	
	3	8000 62703	2	Antivibrante	Silent block	Antivibration	Schwingungsdämpfer	Anti vibrador	
	4	8A00 62704	1	Spina	Pin	Goupille	Stift	Clavija	
	5	8000 62705	1	Graffetta	Clip	Agrafe	Klemmstueck	Clip	
	6	8000 62651	2	Antivibrante	Silent block	Antivibration	Schwingungsdämpfer	Anti vibrador	
	7	8000 62652	1	Distanziale	Spacer	Entretoise	Distanzstück	Separador	
	8	8000 67143	1	Supporto inf.	Support	Support	Halterung	Soporte	
	9	8000 62651	2	Antivibrante	Silent block	Antivibration	Schwingungsdämpfer	Anti vibrador	
	10	8000 04898	2	Rosetta	Washer	Rondelle	Scheibe	Arandela	
	11	8000 62705	2	Graffetta	Clip	Agrafe	Klemmstueck	Clip	
	12	8000 62720	1	Manicotto	Sleeve	Manchon	Muffe	Manguito	
	13	7415 0261B	2	Fascetta	Clamp	Collier	Schelle	Banda	
	14	7415 0111B	1	Fascetta	Clamp	Collier	Schelle	Banda	
	15	8000 62721	1	Manicotto	Sleeve	Manchon	Muffe	Manguito	
	16	8A00 47686	1	Termostato	Thermo switch	Thermostate	Thermostat	Termostato	
	17	8000 62717	1	Coperchio	Cover	Couvercle	Deckel	Tapa	
	18	8000 47701	1	Guarnizione	Gasket	Garnitue	Dichtung	Junta	
	19	8000 57536	1	Guarnizione	Gasket	Garnitue	Dichtung	Junta	
	20	60N1 07335	2	Vite	Screw	Vis	Schraube	Tornillo	
	21	8000 59980	1	Albero	Shaft	Arbre	Welle	Eje	
	22	8000 42285	1	Ingranaggio	Gear	Engrenage	Zahnrad	Engranaje	
	23	8000 42259	1	Rullino	Roller	Aiguille	Rolle	Rodillo	
	24	66N0 21202	1	Anello elastico	Split ring	Anneau ressort	Sprengring	Anillo elástico	
	25	8000 60415	1	Girante	Rotor	Couronne	Lauftrad	Rotor	
	26	8000 42278	1	Dado	Nut	Ecrou	Mutter	Tuerca	
	27	8C00 67963	1	Fascetta	Clamp	Collier	Schelle	Banda	
	28	7415 0251B	1	Fascetta	Clamp	Collier	Schelle	Banda	
	29	7415 0231B	1	Fascetta	Clamp	Collier	Schelle	Banda	
	30	8P00 66179	1	Sfiato	Breather pipe	Évent	Entlüfter	Purga	
	31	8A00 68666	1	Fascetta	Clamp	Collier	Schelle	Banda	
	32	8000 30319	1	Rosetta	Washer	Rondelle	Scheibe	Arandela	
KZ	33	8000 62726	1	Vite	Screw	Vis	Schraube	Tornillo	

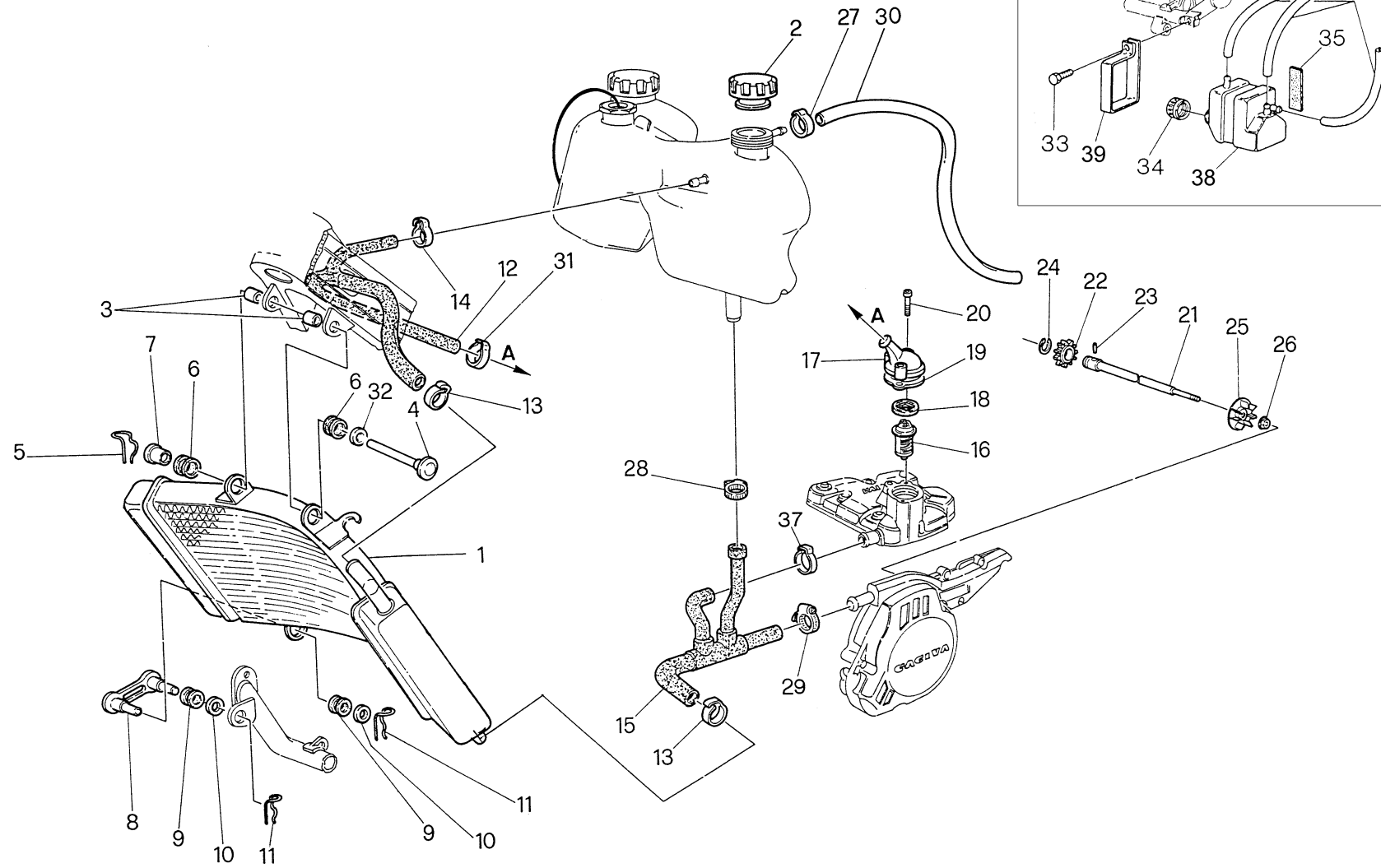

**RAFFREDDAMENTO - COOLING  
REFROIDISSEMENT - WASSERKÜHLUNG  
ENFRIAMIENTO**

Note Notes Notas	Pos. No. Index Pos.	N. Cod. Code No. Nr. Code Code Nr N. Cod.	Q.tà Q.ty Q.te M.ge C.ad	DENOMINAZIONE	NAME	DESIGNATION	BESHREIBUNG	DENOMINACION	Validità Validity Validité Gültig Valides
KZ	34	8000 40427	1	Tappo	Plug	Bouchon	Verschluss	Tapón	
KZ	35	8000 48801	1	Antivibrante	Silent block	Antivibration	Schwingungsdämpfer	Anti vibrador	
KZ	36	8000 79146	1	Gruppo tubi sfiato	Breather pipe group	Set évent	Entlüftergruppe Kpl.	Grupo purga	
	37	7415 0211B	1	Fascetta	Clamp	Collier	Schelle	Banda	
KZ	38	8000 73115	1	Serbatoio vapori	Tank	Reservoir	Tank	Deposito	
KZ	39	8000 73111	1	Fascetta	Clamp	Collier	Schelle	Banda	
K				A richiesta per kit S.P. '99 cod. 800092789	Upon request for S.P. kit '99 code 800092789	Sur demande pour set S.P. '99 code 800092789	Auf Anfrage für Kit S.P. '99 Code 800092789	Bajo pedido por kit S.P. '99 cod. 800092789	
Z				A richiesta per kit S.P. '01 cod. 800097946	Upon request for S.P. kit '01 code 800097946	Sur demande pour set S.P. '01 code 800092789	Auf Anfrage für Kit S.P. '01 Code 800097946	Bajo pedido por kit S.P. '01 cod. 800097946	

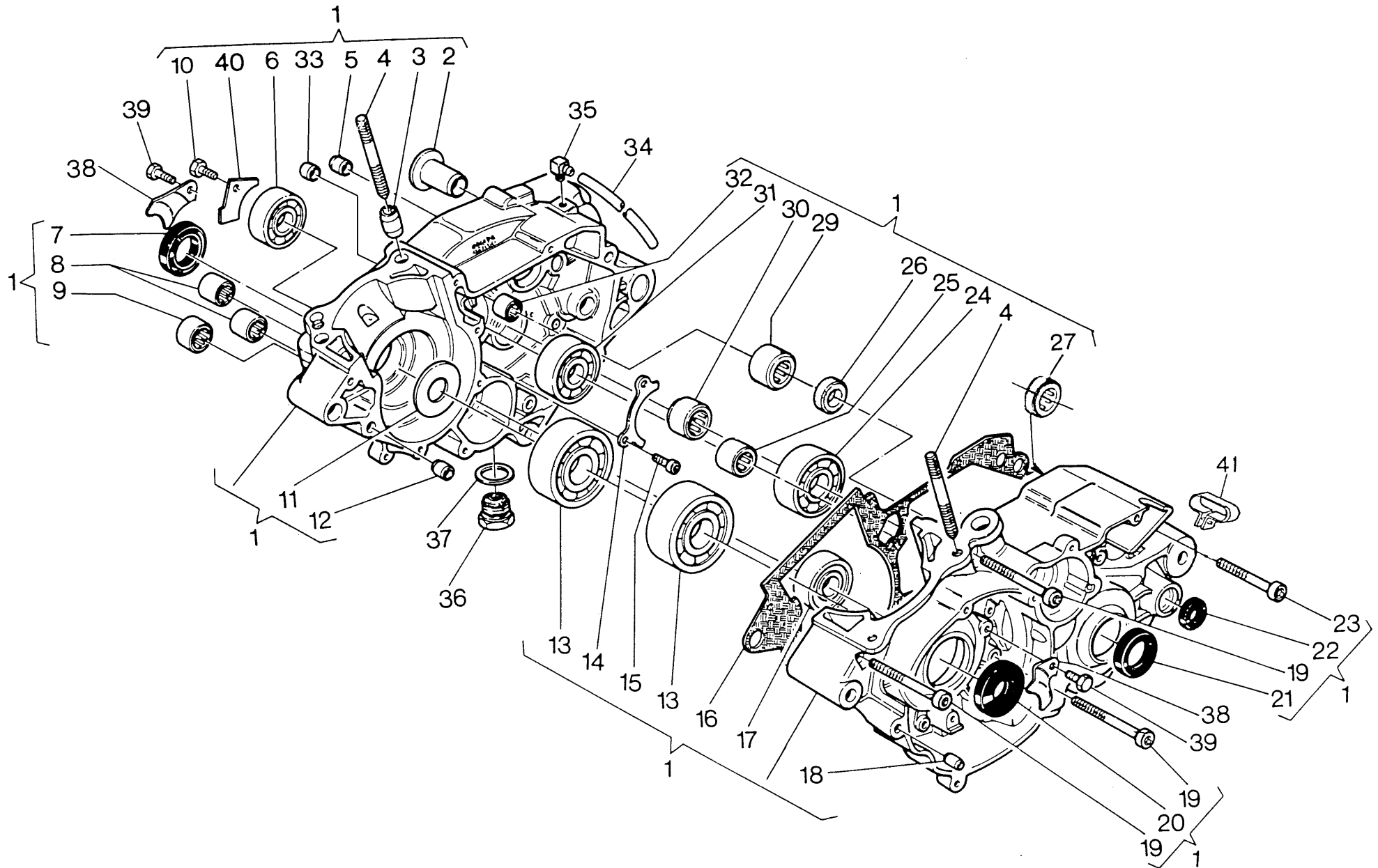

Note Notes Marka Notas	Pos. No. Index Pos.	N. Cod. Code No. Nr. Code N. Cod.	Q.tà Q.ty Q.te M.ge C.ad	DENOMINAZIONE	NAME	DESIGNATION	BESHREIBUNG	DENOMINACION	Validità Validity Validité Gültig Valides
	1	8000 99355	1	Carter motore compl.	Crankcase assy	Carter compl.	Kurberlgehaue kpl.	Carter motor completi	
	2	8000 33642	2	Bussola per asse forcellone	Bushing	Douille	Büchse	Manguito	
	3	8000 47708	2	Bussola rif. cilindro	Bushing	Douille	Büchse	Manguito	
	4	8000 30860	4	Prigioniero	Stud bolt	Prisonnier	Stiftschraube	Prisionero	
	5	8000 51971	2	Bussola	Bushing	Douille	Büchse	Manguito	
	6	8000 53248	1	Cuscinetto contralbero	Bearing	Roulement	Lager	Cojinete	
	7	8000 30728	1	Anello di tenuta	Seal ring	Bague d'étanchéité	Dichtungsring	Anillo de retención	
	8	8000 47678	2	Boccola	Bush	Douille	Büchse	Casquillo	
	9	8000 49016	1	Cuscinetto rinvio contralbero	Needle bearing	Roulement à aiguilles	Nadelkäfig	Cojinete	
	10	60N1 01078	1	Vite di fissaggio	Screw	Vis	Schraube	Tornillo	
	11	8000 42164	1	Rosetta	Washer	Rondelle	Scheibe	Arandela	
	12	8000 07719	2	Bussola di riferimento	Bushing	Douille	Büchse	Manguito	
	13	8000 98349	2	Cuscinetto albero motore	Bearing	Roulement	Lager	Cojinete	
	14	8000 48861	1	Piastrina	Plate	Plaquette	Plättchen	Placa	
	15	60N1 02483	2	Vite	Screw	Vis	Schraube	Tornillo	
	16	8000 48862	1	Guarnizione	Gasket	Garnitue	Dichtung	Junta	
	17	8000 53248	1	Cuscinetto contralbero	Bearing	Roulement	Lager	Cojinete	
	18	8000 51549	2	Spina	Pin	Goupille	Stift	Clavija	
	19	60N1 02516	3	Vite	Screw	Vis	Schraube	Tornillo	
	20	8000 32389	1	Anello di tenuta	Seal ring	Bague d'étanchéité	Dichtungsring	Anillo de retención	
	21	8000 36357	1	Anello di tenuta	Seal ring	Bague d'étanchéité	Dichtungsring	Anillo de retención	
	22	8000 22946	1	Anello di tenuta	Seal ring	Bague d'étanchéité	Dichtungsring	Anillo de retención	
	23	60N1 02515	8	Vite	Screw	Vis	Schraube	Tornillo	
	24	8000 24947	1	Cuscinetto albero secondario	Bearing	Roulement	Lager	Cojinete	
	25	8000 37198	1	Cuscinetto a rullini albero	Needle bearing	Roulement à aiguilles	Nadelkäfig	Cojinete	
	26	8000 53339	1	Anello di tenuta per pompa	Seal ring	Bague d'étanchéité	Dichtungsring	Segmento de compresión	
	27	8000 62200	1	Cuscinetto	Bearing	Roulement	Lager	Cojinete	
	29	8000 47678	1	Cuscinetto albero pompa acqua	Bearing	Roulement	Lager	Cojinete	
	30	8000 36440	1	Cuscinetto albero secondario	Bearing	Roulement	Lager	Cojinete	
	31	8000 43382	1	Cuscinetto albero primario	Bearing	Roulement	Lager	Cojinete	
	32	8000 33718	1	Boccola	Bush	Douille	Büchse	Casquillo	
	33	8000 57196	1	Tappo foro avviamento	Plug	Bouchon	Verschluss	Tapòn	
	34	8B00 41750	1	Tubetto	Pipe	Tuyau	Rohr	Tube	

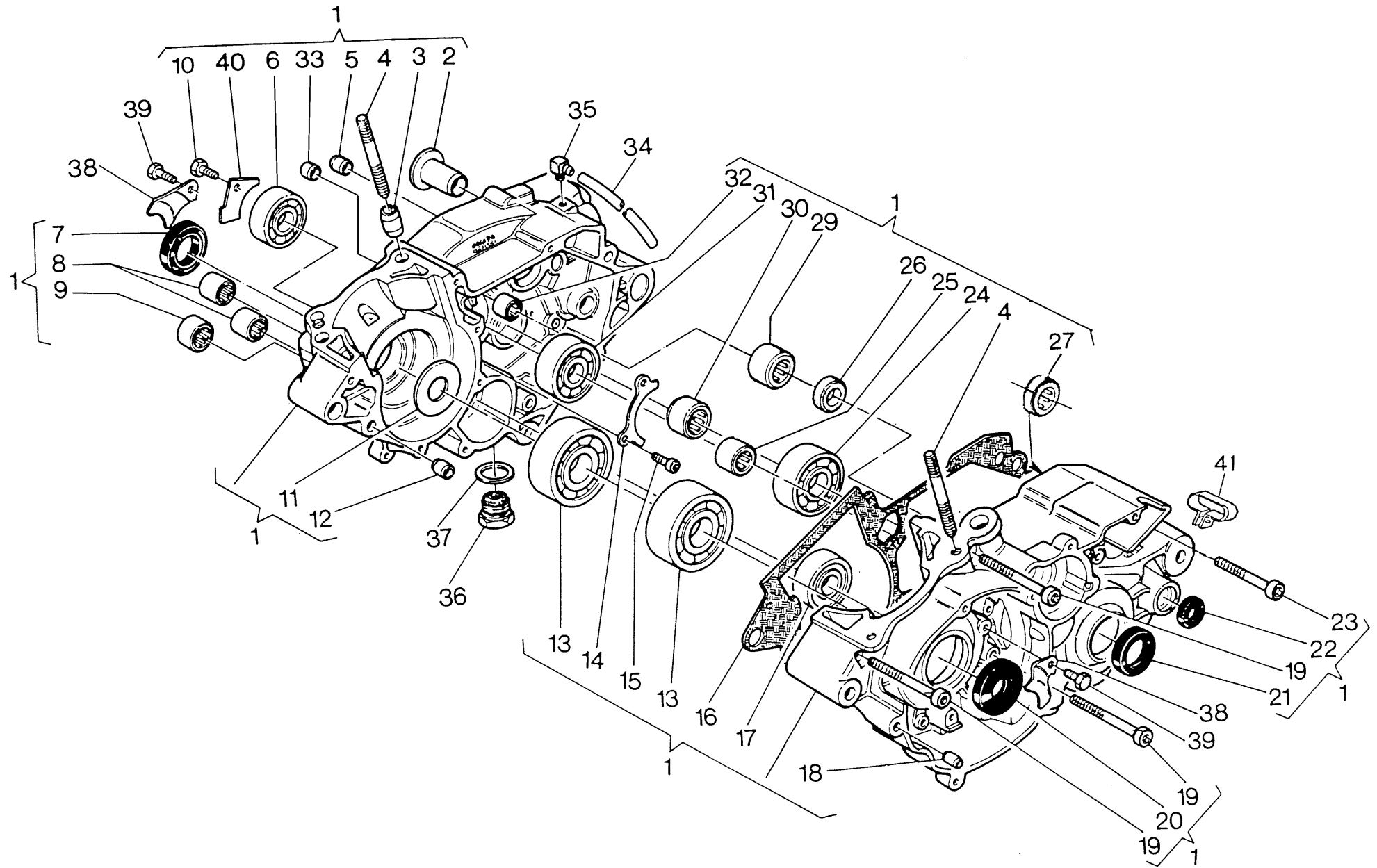

Note Notes Marka Notas	Pos. No. Index Pos.	N. Cod. Code No. Nr. Code Code Nr N. Cod.	Q.tà Q.ty Q.te M.ge C.ad	DENOMINAZIONE	NAME	DESIGNATION	BESHREIBUNG	DENOMINACION	Validità Validity Validité Gültig Valides
	35	8000 19620	1	Raccordo	Union	Raccord	Anschluss	Empalme	
	36	8000 57182	1	Tappo magnetico	Plug	Bouchon	Verschluss	Tapòn	
KZ	36	8000 73049	1	Tappo scarico olio	Plug	Bouchon	Verschluss	Tapòn	
	37	8B00 06725	1	Guarnizione	Gasket	Garnitue	Dichtung	Junta	
	38	8000 46393	2	Piastrina	Plate	Plaquette	Plättchen	Placa	
	39	60N1 01878	2	Vite di fissaggio	Screw	Vis	Schraube	Tornillo	
	40	8000 48848	1	Piastrina	Plate	Plaquette	Plättchen	Placa	
	41	8000 67957	1	Passacavo	Fairlead	Passa-cable	Kabelführung	Prensa-cable	
K				A richiesta per kit S.P. '99 cod. 800092789	Upon request for S.P. kit '99 code 800092789	Sur demande pour set S.P. '99 code 800092789	Auf Anfrage für Kit S.P. '99 Code 800092789	Bajo pedido por kit S.P. '99 cod. 800092789	
Z				A richiesta per kit S.P. '01 cod. 800097946	Upon request for S.P. kit '01 code 800097946	Sur demande pour set S.P. '01 code 800092789	Auf Anfrage für Kit S.P. '01 Code 800097946	Bajo pedido por kit S.P. '01 cod. 800097946	

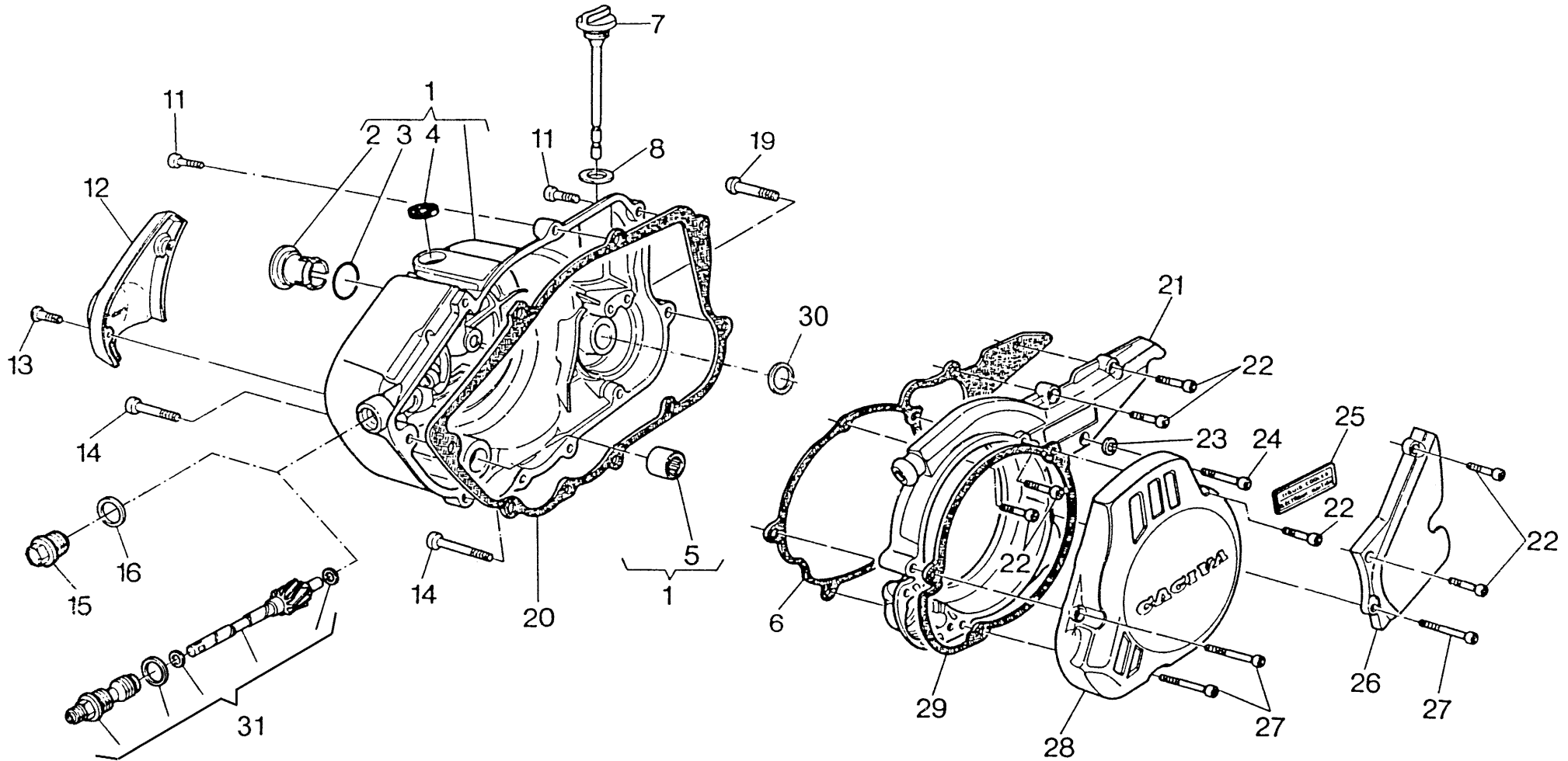



Note Notes Notas	Pos. No. Index Pos.	N. Cod. Code No. Nr. Code Code Nr N. Cod.	Q.tà Q.ty Q.te M.ge C.ad	DENOMINAZIONE	NAME	DESIGNATION	BESHREIBUNG	DENOMINACION	Validità Validity Validité Gültig Valides
	1	80C0 66843	1	Assieme coperchio destro	Right cover assembly	Ensemble couvercle droit	Aggregat rechter Dekel	Juego tapa derecha	
	2	8000 56006	1	Tappo	Plug	Bouchon	Verschluss	Tapón	
	3	8000 34323	1	Anello di tenuta	Seal ring	Bague d'étanchéité	Dichtungsring	Anillo de retención	
	4	8000 48856	1	Anello di tenuta	Seal ring	Bague d'étanchéité	Dichtungsring	Anillo de retención	
	5	8000 49016	1	Cuscinetto a rullini	Needle bearing	Roulement à aiguilles	Nadelkäfig	Cojinete	
	6	8000 48865	1	Guarnizione	Gasket	Garnitue	Dichtung	Junta	
	7	8000 57185	1	Tappo	Plug	Bouchon	Verschluss	Tapón	
	8	8000 27960	1	Rosetta	Washer	Rondelle	Scheibe	Arandela	
	11	60N1 02510	6	Vite	Screw	Vis	Schraube	Tornillo	
	12	80A0 66845	1	Coperchio pompa olio	Oil pump cover	Couvercle pompe a huile	Ölpumpendeckel	Tapa bomba aceite	
	13	8000 24962	2	Vite	Screw	Vis	Schraube	Tornillo	
	14	60N1 02512	2	Vite	Screw	Vis	Schraube	Tornillo	
	15	80A0 31817	1	Tappo	Plug	Bouchon	Verschluss	Tapón	
	16	62N0 15599	1	Rosetta	Washer	Rondelle	Scheibe	Arandela	
	19	60N1 02512	1	Vite	Screw	Vis	Schraube	Tornillo	
	20	8000 48864	1	Guarnizione	Gasket	Garnitue	Dichtung	Junta	
	21	8000 47375	1	Flangia	Flange	Bride	Flansch	Brida	
	22	60N1 07335	7	Vite	Screw	Vis	Schraube	Tornillo	
	23	8000 15960	1	Guarnizione	Gasket	Garnitue	Dichtung	Junta	
	24	60N1 02511	1	Vite	Screw	Vis	Schraube	Tornillo	
	25	8000 38078	1	Targhetta autoadesiva	Trim	Décalcomanie	Abziehbild	Autoadhesivos	
	26	80A0 88204	1	Coperchio pignone	Cover	Couvercle	Deckel	Tapa	
	27	60N1 02515	3	Vite	Screw	Vis	Schraube	Tornillo	
	28	80B0 66847	1	Coperchio vano accensione	Cover	Couvercle	Deckel	Tapa	
	29	8000 52292	1	Guarnizione	Gasket	Garnitue	Dichtung	Junta	
KZ	30	8000 36653	1	Anello di tenuta	Seal ring	Bague d'étanchéité	Dichtungsring	Anillo de retención	
KZ	31	8000 52232	1	Ass. rinvio contagiri	Driving gear assy	Renvoi compl.	Vorgelege Kpl.	Reenvio cuenta revoluciones compl.	
K				A richiesta per kit S.P. '99 cod. 800092789	Upon request for S.P. kit '99 code 800092789	Sur demande pour set S.P. '99 code 800092789	Auf Anfrage für Kit S.P. '99 Code 800092789	Bajo pedido por kit S.P. '99 cod. 800092789	
Z				A richiesta per kit S.P. '01 cod. 800097946	Upon request for S.P. kit '01 code 800097946	Sur demande pour set S.P. '01 code 800092789	Auf Anfrage für Kit S.P. '01 Code 800097946	Bajo pedido por kit S.P. '01 cod. 800097946	

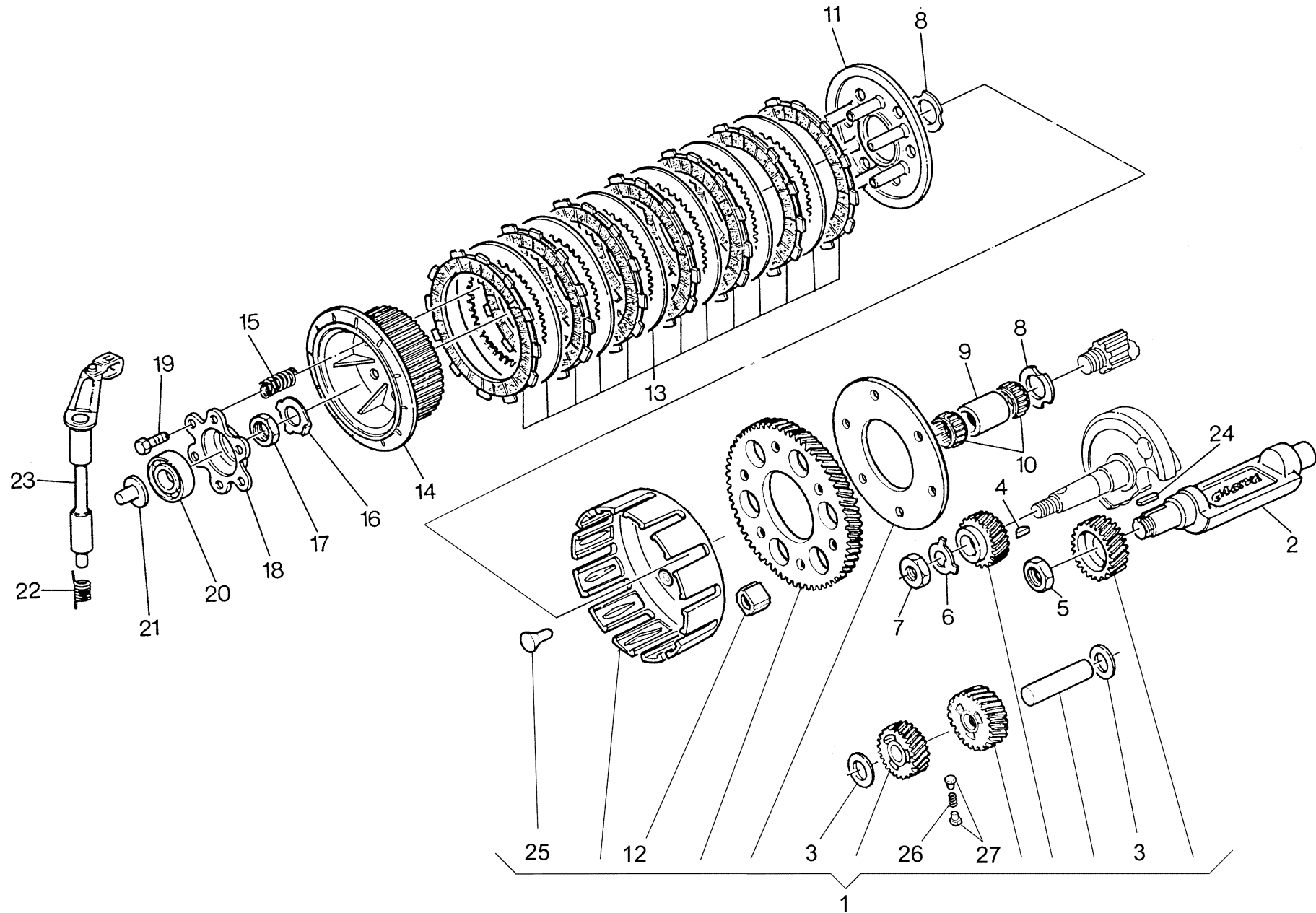

**FRIZIONE, CONTRALBERO, TRASM. PRIMARIA - CLUTCH, LAYSHAFT, PRIMARY DRIVE  
 EMBRAYAGE, ARBRE DE BAL, TRANS. PRIMARIE - KUPPLUNG, VORGELEGEWELLE, ERSTERANTRIEB  
 ENBRAGUE, CONTRA-EJE TRANSM. PRIMARIA**

Note Notes Marke Notas	Pos. No. N. Index Pos.	N. Cod. Code No. Nr. Code Code Nr N. Cod.	Q.tà Q.ty Q.te M.ge C.ad	DENOMINAZIONE	NAME	DESIGNATION	BESHREIBUNG	DENOMINACION	Validità Validity Validité Gültig Valides
	1	8000 64833	1	Coppia ingranaggi primaria	Set of matched primary	Engrenages trans. prim.	Stirnraderpaar	Copla engranaje trans. primar.	
	2	8000 47719	1	Contralbero di equilibrio	Layshaft	Arbre de bal.	Worgelegewelle	Contra eje	
	3	8000 11868	2	Rosetta di rasam. sp. 0,3 mm.	Washer	Rondelle	Scheibe	Arandela	
	3	8A00 11868	2	Rosetta di rasam. sp. 0,5 mm.	Washer	Rondelle	Scheibe	Arandela	
	3	8B00 11868	2	Rosetta di rasam. sp. 0,6 mm.	Washer	Rondelle	Scheibe	Arandela	
	3	8C00 11868	2	Rosetta di rasam. sp. 0,7 mm.	Washer	Rondelle	Scheibe	Arandela	
	3	8D00 11868	2	Rosetta di rasam. sp. 0,8 mm.	Washer	Rondelle	Scheibe	Arandela	
	3	8E00 11868	2	Rosetta di rasam. sp. 0,9 mm.	Washer	Rondelle	Scheibe	Arandela	
	3	8F00 11868	2	Rosetta di rasam. sp. 1 mm.	Washer	Rondelle	Scheibe	Arandela	
	3	8G00 11868	2	Rosetta di rasam. sp. 1,1 mm.	Washer	Rondelle	Scheibe	Arandela	
	3	8H00 11868	2	Rosetta di rasam. sp. 1,2 mm.	Washer	Rondelle	Scheibe	Arandela	
	4	65N0 21007	1	Linguetta	Woodruff key	Clé woodruff	Federkeil	Lengueta	
	5	80A0 47665	1	Dado	Nut	Ecrou	Mutter	Tuerca	
	6	8000 31739	1	Rosetta	Washer	Rondelle	Scheibe	Arandela	
	7	80A0 47665	1	Dado	Nut	Ecrou	Mutter	Tuerca	
	8	8000 46428	2	Rosetta	Washer	Rondelle	Scheibe	Arandela	
	9	8000 42288	1	Distanziale	Spacer	Entretoise	Distanzstück	Separador	
	10	8000 25044	2	Gabbia a rullini	Needle cage	Cage à aiguilles	Nadelkaefig	Jaula de agujas del cojinete	
	11	8000 31813	1	Disco premifrizione	Disc	Disque	Scheibe	Disco	
	12	8000 31378	6	Anello parastrappi	Flexible coupling	Para fente	Gummidämpfer	Para tirones	
	13	8000 82864	1	Ass. gruppo frizione	Clutch group assy	Groupe embrayage compl.	Kupplungsgruppe Kpl	Grupo embrague compl.	
	14	8000 48874	1	Mozzo portadischi	Clutch hub	Moyeu porte disque	Scheibenhalternabe	Porta discos	
	15	8000 44346	6	Molla frizione	Clutch spring	Ressort embrayage	Kupplungsfeder	Resorte embrague	
KZ	15	8000 40220	6	Molla frizione	Clutch spring	Ressort embrayage	Kupplungsfeder	Resorte embrague	
	16	8000 38727	1	Rosetta	Washer	Rondelle	Scheibe	Arandela	
	17	8000 38726	1	Dado	Nut	Ecrou	Mutter	Tuerca	
	18	8000 48875	1	Disco ritegno molle	Plate	Disque	Platte	Disco	
	19	8000 30820	6	Vite	Screw	Vis	Schraube	Tornillo	
	20	8000 01025	1	Cuscinetto	Bearing	Roulement	Lager	Cojinete	
	21	8000 48852	1	Piattello	Plate	Plateau	Teller	Placa	
	22	8000 48855	1	Molla richiamo	Spring	Ressort	Feder	Resorte	
	23	8000 48853	1	Ass. leva comando frizione	Clutch control lever, assy	Levier comm. embray. compl.	Kupplungshebel, Kpl.	Palanca embrague comp.	
	24	8000 38707	1	Linguetta	Woodruff key	Clé woodruff	Federkeil	Lengueta	

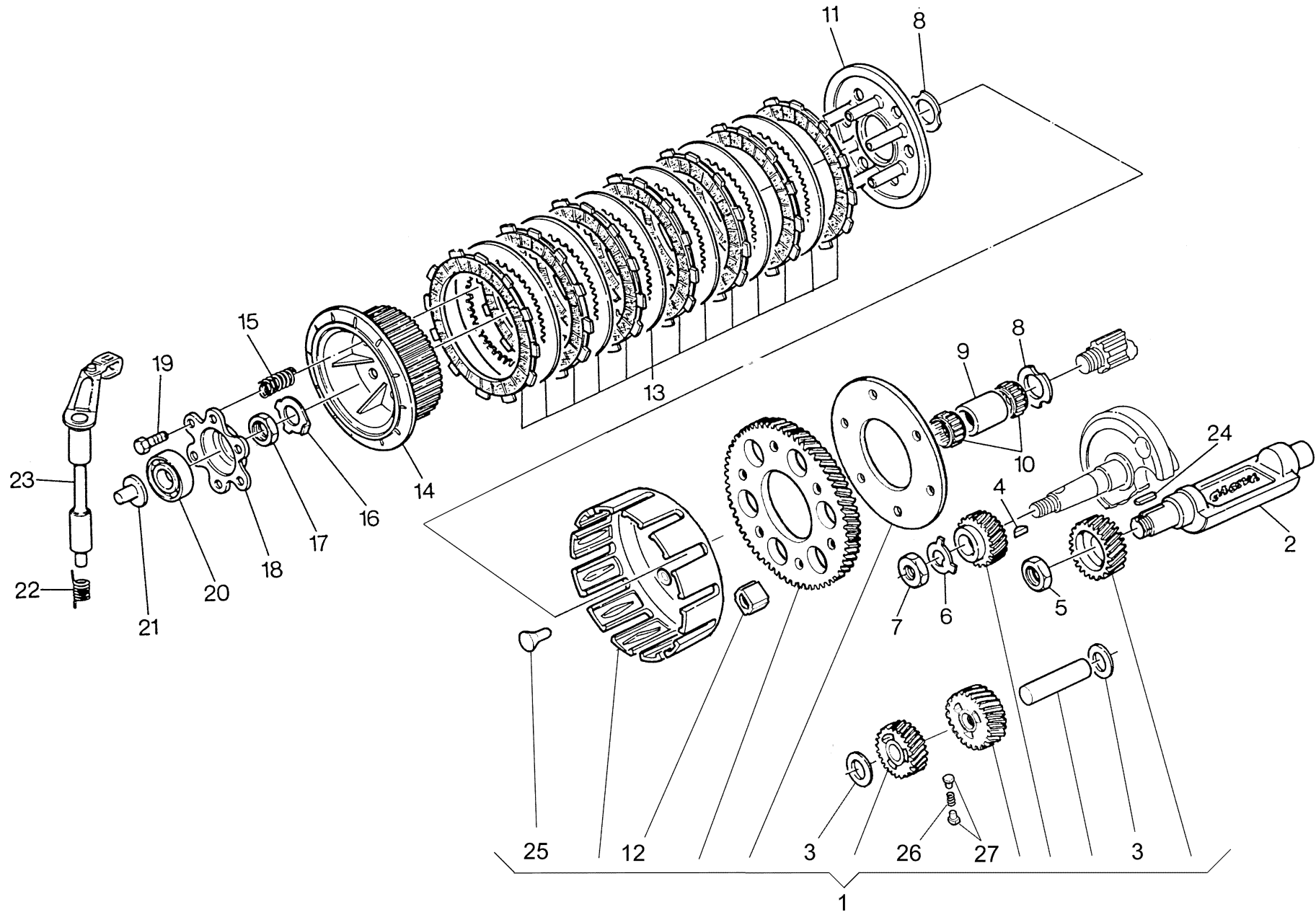

**FRIZIONE, CONTRALBERO, TRASM. PRIMARIA - CLUTCH, LAYSHAFT, PRIMARY DRIVE  
 EMBRAYAGE, ARBRE DE BAL, TRANS. PRIMARIE - KUPPLUNG, VORGELEGEWELLE, ERSTERANTRIEB  
 ENBRAGUE, CONTRA-EJE TRANSM. PRIMARIA**

Note Notes Marke Notas	Pos. No. Index Pos.	N. Cod. Code No. Nr. Code Code Nr N. Cod.	Q.tà Q.ty Q.te M.ge C.ad	DENOMINAZIONE	NAME	DESIGNATION	BESHREIBUNG	DENOMINACION	Validità Validity Validité Gültig Valides
	25	63NO 16349	6	Rivetto svasato	Rivet	Rivet	Niet	Remache	
	26	8000 55587	3	Molla per parastrappi	Spring	Ressort	Feder	Resorte	
	27	8000 55588	6	Perno per parastrappi	Pin	Pivot	Bolzen	Perno	
K				A richiesta per kit S.P. '99 cod. 800092789	Upon request for S.P. kit '99 code 800092789	Sur demande pour set S.P. '99 code 800092789	Auf Anfrage für Kit S.P. '99 Code 800092789	Bajo pedido por kit S.P. '99 cod. 800092789	
Z				A richiesta per kit S.P. '01 cod. 800097946	Upon request for S.P. kit '01 code 800097946	Sur demande pour set S.P. '01 code 800092789	Auf Anfrage für Kit S.P. '01 Code 800097946	Bajo pedido por kit S.P. '01 cod. 800097946	

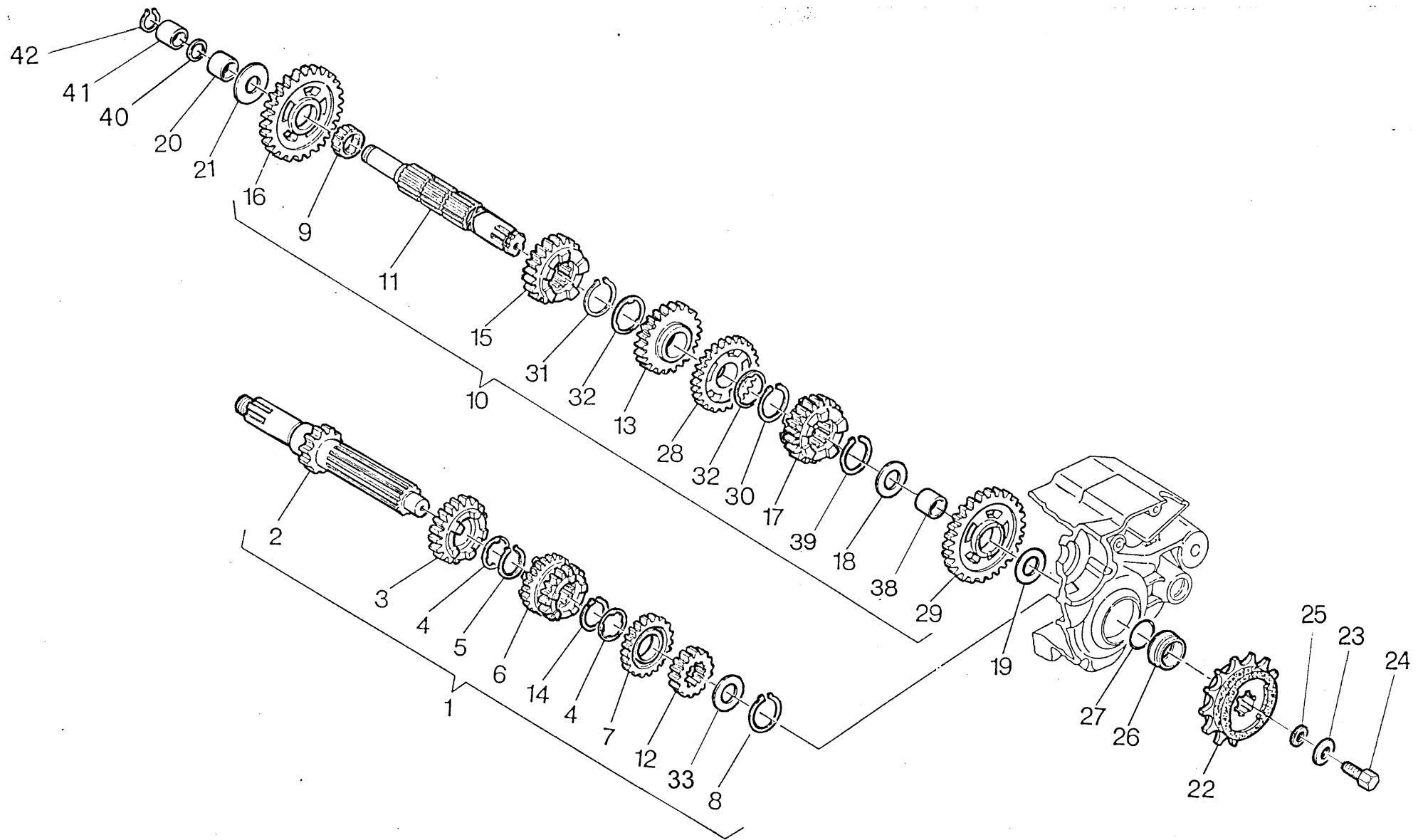

**CAMBIO - TRANSMISSION  
BOITE DE VITESSE - WECHSELGETRIEBE  
CAMBIO**

Note Notes Notas	Pos. No. Index Pos.	N. Cod. Code No. Nr. Code N. Cod.	Q.tà Q.ty Q.te M.ge C.ad	DENOMINAZIONE	NAME	DESIGNATION	BESHREIBUNG	DENOMINACION	Validità Validity Validité Gültig Valides
	1	8000 69247	1	Ass. albero primario	Main shaft compl.	Arbre primaire compl.	Hauptwelle, Kpl.	primario comp.	
	2	8000 69248	1	Albero primario Z=11	Main shaft	Arbre primaire	Hauptwelle	Eje primario	
	3	8000 52447	1	Ingran. 6ª velocità A.P. Z=22	Main shaft 6th gear	Engrenage 6ème vitesse A.P.	Zahn. f. 6. Geschw. Antriebsw.	Engranaje 6° velocidad Eje P.	
	4	8000 25151	2	Rosetta di rasamento	Thrust washer	Rondelle de butée	Ausgleichscheibe	Arandela de tope	
	5	60N2 21208	1	Anello elastico	Ring	Bague	Sprengring	Anillo elástico	
	6	8000 46532		Ingranaggio 3ª vel. Z=17 e 4ª vel. Z=21 A.P.	Driven gear 3rd and 4th speed	Engrenage conduit 3ème et 4 éme	Zahnrad 3. u. 4. Gang	Engr. 3° y 4° velocidad	
	7	8000 53130	1	Ingranaggio 5ª vel. A.P. Z=23	Gear 5th speed	Engrenage 5ème	Zahnrad 5. Gang	Engranaje 5° velocidad	
	8	8000 53392	1	Anello elastico	Ring	Bague	Sprengring	Anillo elástico	
	9	8000 31773	1	Cuscinetti a rullini	Needle bearing	Roulement à rouleaux	Nadelkäfig	Cojinete de rodillos	
	10	8000 69252	1	Ass. albero secondario	Layshaft compl.	Arbre secondaire compl.	Vorgelegewelle, Kpl.	secondario comp.	
	11	8000 69273	1	Albero secondario	Layshaft	Arbre secondaire	Vorgelegewelle	secondario	
	12	8000 69249	1	Ingranaggio 2ª vel. A.P. Z=14	Main shaft 2rd gear	Engrenage 2ème vitesse A.P.	Zahn. f. 2. Geschw. Antriebsw.	Engranaje 2° velocidad Eje P.	
	13	8000 46534	1	Ingranaggio 4ª vel. A.S. Z=23	Secondary shaft 4th gear	Engrenage 4ème vitesse A.S.	Zahn.f.4. Geschw. Vorgelegew.	Engranaje 4° velocidad Eje S.	
	14	8000 34690	1	Anello elastico	Ring	Bague	Sprengring	Anillo elástico	
	15	8000 52448	1	Ingranaggio 6ª vel. Z=19 A.S	Secondary shaft 6th gear	Engrenage 6ème vitesse A.S.	Zahn. f. 6.Geschw.Vorgelegew.	Engranaje 6° velocidad Eje S.	
	16	8000 54695	1	Ingranaggio 1ª vel. Z=30 A.S.	Gear 1st speed	Engrenage 1ère	Zahnrad 1. Gang	Engranaje 1° velocidad	
	17	8000 69250	1	Ingranaggio 5ª vel. Z=22 A.S.	Gear 5th speed	Engrenage 5ème	Zahnrad 5. Gang	Engranaje 5° velocidad	
	18	8000 43199	1	Rosetta di rasamento	Thrust washer	Rondelle de butée	Ausgleichscheibe	Arandela de tope	
	19	8000 07989	1	Rosetta di rasam. sp.0,3 mm	Thrust washer	Rondelle de butée	Ausgleichscheibe	Arandela de tope	
	19	8B00 07989	1	Rosetta di rasam. sp.0,5 mm	Thrust washer	Rondelle de butée	Ausgleichscheibe	Arandela de tope	
	19	8E00 07989	1	Rosetta di rasam. sp.0,8 mm	Thrust washer	Rondelle de butée	Ausgleichscheibe	Arandela de tope	
	19	8G00 07989	1	Rosetta di rasam. sp.1,0 mm	Thrust washer	Rondelle de butée	Ausgleichscheibe	Arandela de tope	
	19	8I00 07989	1	Rosetta di rasam. sp.1,2 mm	Thrust washer	Rondelle de butée	Ausgleichscheibe	Arandela de tope	
	20	8000 54874	1	Anello	Ring	Bague	Ring	Anillo	
	21	8000 05272	1	Rosetta di rasam. sp.0,3 mm	Thrust washer	Rondelle de butée	Ausgleichscheibe	Arandela de tope	
	21	8C00 05272	1	Rosetta di rasam. sp.0,8 mm	Thrust washer	Rondelle de butée	Ausgleichscheibe	Arandela de tope	
	21	8E00 05272	1	Rosetta di rasam. sp.1,0 mm	Thrust washer	Rondelle de butée	Ausgleichscheibe	Arandela de tope	
	21	8G00 05272	1	Rosetta di rasam. sp.1,2 mm	Thrust washer	Rondelle de butée	Ausgleichscheibe	Arandela de tope	
	22	8000 49778	1	Pignone uscita cambio Z=14.	Pinion	Pignon	Ritzel	Piñón	
KZ	22	8A00 68003	1	Pignone uscita cambio Z=16	Pinion	Pignon	Ritzel	Piñón	
KZ	22	8000 68003	1	Pignone uscita cambio Z=17	Pinion	Pignon	Ritzel	Piñón	
KZ	22	8B00 68003	1	Pignone uscita cambio Z=18	Pinion	Pignon	Ritzel	Piñón	

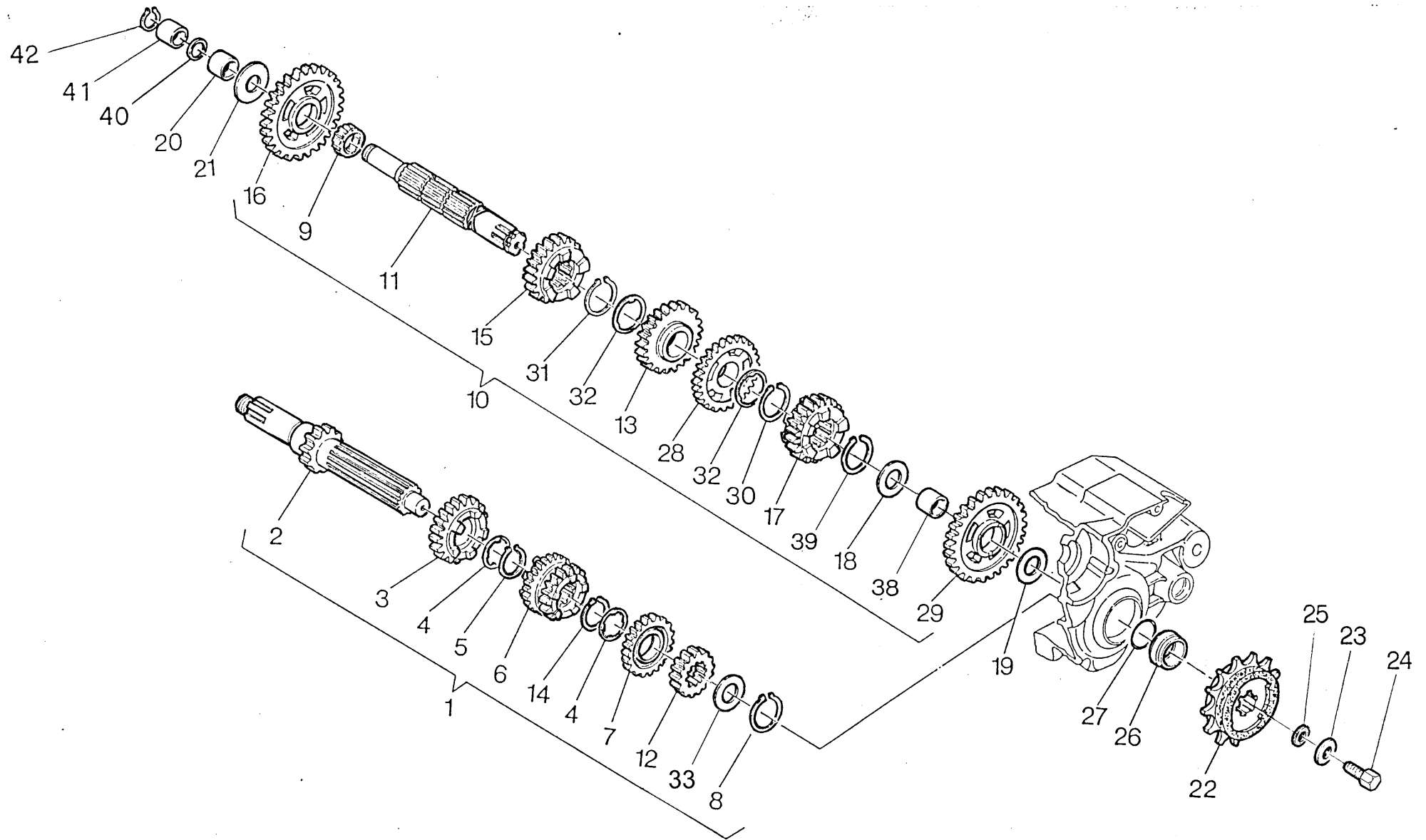



**CAMBIO - TRANSMISSION  
BOITE DE VITESSE - WECHSELGETRIEBE  
CAMBIO**

Note Notes Marken Notas	Pos. No. Index Pos.	N. Cod. Code No. Nr. Code Code Nr N. Cod.	Q.tà Q.ty Q.te M.ge C.ad	DENOMINAZIONE	NAME	DESIGNATION	BESHREIBUNG	DENOMINACION	Validità Validity Validité Gültig Valides
	23	8000 73650	1	Rosetta di sicurezza	Washer	Rondelle	Scheibe	Arandela	
	24	60N1 01140	1	Vite	Screw	Vis	Schraube	Tornillo	
KZ	24	8A00 62153	1	Vite	Screw	Vis	Schraube	Tornillo	
	25	8000 73649	1	Rosetta	Washer	Rondelle	Scheibe	Arandela	
KZ	25	8000 62154	1	Rosetta	Washer	Rondelle	Scheibe	Arandela	
	26	8A00 31744	1	Distanziale	Spacer	Entretoise	Distanzstück	Separador	
	27	8000 19789	1	Anello OR	O-Ring	Bague OR	O-Ring	Anillo OR	
	28	8000 46533	1	Ingranaggio 3 <sup>a</sup> vel. A.S. Z=23	Secondary shaft 3rd gear	Engrenage 3ème vitesse A.S.	Zahnr.f.3.Geschw. Vorgelegew.	Engranaje 3° velocidad Eje S.	
	29	8000 69251	1	Ingranaggio 2 <sup>a</sup> vel. A.S. Z=26	Secondary shaft 2rd gear	Engrenage 2ème vitesse A.S.	Zahnr.f.2.Geschw. Vorgelegew.	Engranaje 2° velocidad Eje S.	
	30	8000 31768	1	Anello elastico	Ring	Bague	Sprengring	Anillo elástico	
	31	8000 31768	1	Anello elastico	Ring	Bague	Sprengring	Anillo elástico	
	32	8000 43199	2	Rosetta di rasamento	Thrust washer	Rondelle de butée	Ausgleichscheibe	Arandela de tope	
	33	8000 38210	1	Rosetta di rasam. sp.0,3 mm	Thrust washer	Rondelle de butée	Ausgleichscheibe	Arandela de tope	
	33	8B00 38210	1	Rosetta di rasam. sp.0,5 mm	Thrust washer	Rondelle de butée	Ausgleichscheibe	Arandela de tope	
	33	8D00 38210	1	Rosetta di rasam. sp.0,8 mm	Thrust washer	Rondelle de butée	Ausgleichscheibe	Arandela de tope	
	33	8F00 38210	1	Rosetta di rasam. sp.1,0 mm	Thrust washer	Rondelle de butée	Ausgleichscheibe	Arandela de tope	
	33	8H00 38210	1	Rosetta di rasam. sp.1,2 mm	Thrust washer	Rondelle de butée	Ausgleichscheibe	Arandela de tope	
	38	8000 61261	1	Bussola	Bushing	Douille	Buchse	Manguito	
	39	66N0 21209	1	Anello elastico	Ring	Bague	Sprengring	Anillo elástico	
	40	8D00 04553	1	Rosetta	Washer	Rondelle	Scheibe	Arandela	
	41	8000 56770	1	Distanziale	Spacer	Entretoise	Distanzstück	Separador	
	42	66N0 21204	1	Anello elastico	Ring	Bague	Sprengring	Anillo elástico	
K				A richiesta per kit S.P. '99 cod. 800092789	Upon request for S.P. kit '99 code 800092789	Sur demande pour set S.P. '99 code 800092789	Auf Anfrage für Kit S.P. '99 Code 800092789	Bajo pedido por kit S.P. '99 cod. 800092789	
Z				A richiesta per kit S.P. '01 cod. 800097946	Upon request for S.P. kit '01 code 800097946	Sur demande pour set S.P. '01 code 800092789	Auf Anfrage für Kit S.P. '01 Code 800097946	Bajo pedido por kit S.P. '01 cod. 800097946	

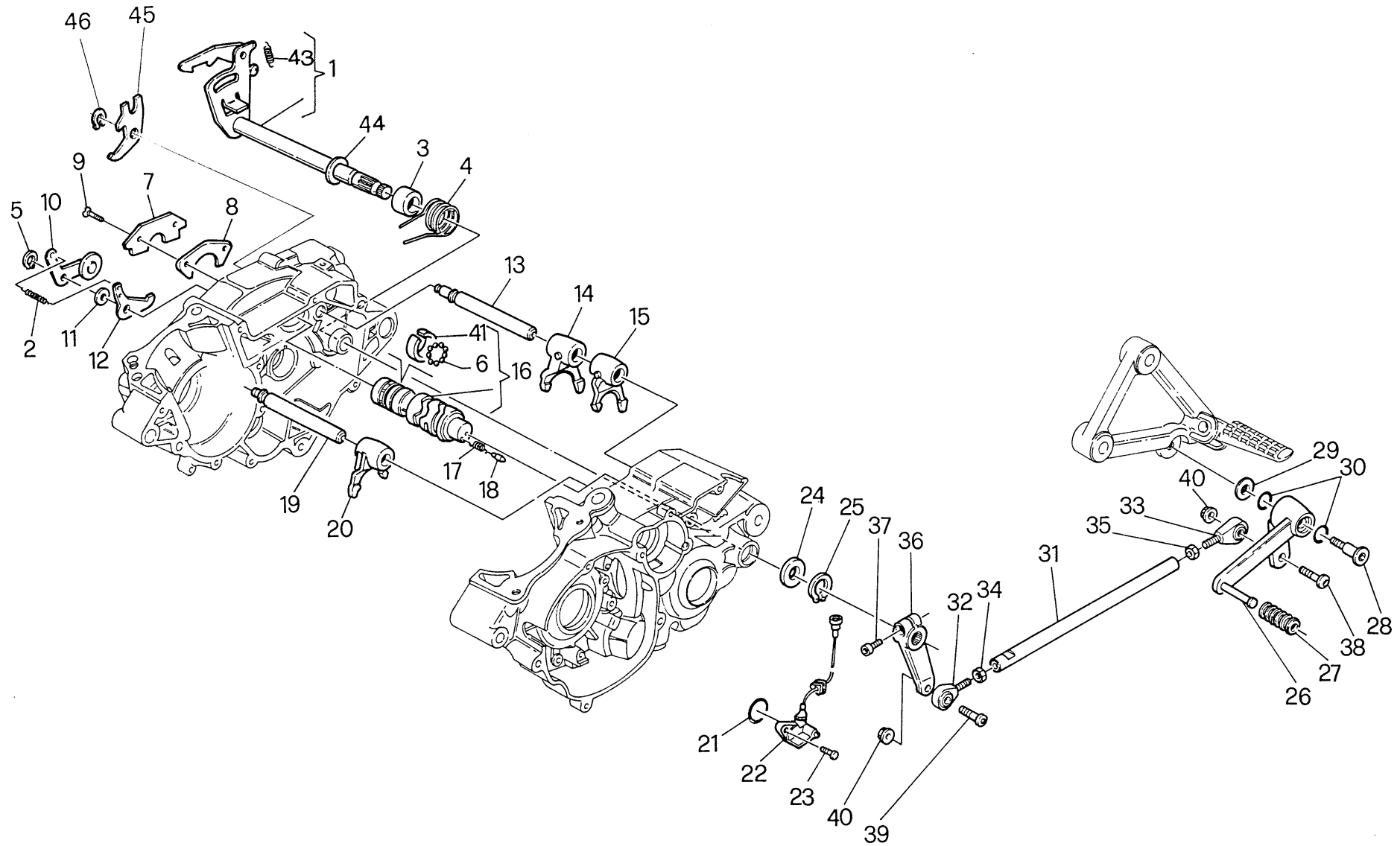

**COMANDO CAMBIO - SHIFTER  
 COMMANDE DE VITESSE - GANGSCHALTUNG  
 MANDO CAMBIO**

Note Notes Notas	Pos. No. Index Pos.	N. Cod. Code No. Nr. Code N. Cod.	Q.tà Q.ty Q.te M.ge C.ad	DENOMINAZIONE	NAME	DESIGNATION	BESHREIBUNG	DENOMINACION	Validità Validity Validité Gültig Valides
	1	8000 62195	1	Assieme selettore	Selector assembly	Ensemble sélecteur	Aggregat Wählschalter	Juego selector	
	2	8000 27103	1	Molla	Spring	Ressort	Feder	Resorte	
	3	8000 24857	1	Bussola	Bushing	Douille	Büchse	Manguito	
	4	8000 62210	1	Molla	Spring	Ressort	Feder	Resorte	
	5	8000 21375	1	Anello elastico	Split ring	Anneau ressort	Sprengring	Anillo elástico	
	6	6BNO 21505	15	Sfera	Ball	Bille	Kugel	Esfera	
	7	8000 24840	1	Piastrina di ritegno	Plate	Plaquette	Plättchen	Placa	
	8	8A00 24841	1	Piastrina di rasam. sp. 0,3 mm.	Plate	Plaquette	Plättchen	Placa	
	8	8000 24841	1	Piastrina di rasam. sp. 0,2 mm.	Plate	Plaquette	Plättchen	Placa	
	9	60N1 03834	2	Vite	Screw	Vis	Schraube	Tornillo	
	10	8000 34035	1	Assieme salterello fissa marce	Gear fixing klik assembly	Cliquet compl.	Strumhaken kpl.	Salt. fijo marchas	
	11	8000 43859	1	Rosetta di rasam. sp. 0,2 mm.	Washer	Rondelle	Scheibe	Arandela	
	11	8A00 43859	1	Rosetta di rasam. sp. 0,3 mm.	Washer	Rondelle	Scheibe	Arandela	
	12	8000 44300	1	Salterello fissa folle	Pawl	Clique	Sturmhaken	Salt. fijo neutro	
	13	8000 24839	1	Perno forc. 1ª, 2ª, 3ª, 4ª, vel.	Pin 1st, 2nd, 3rd, 4th	Pivot 1ème, 2ème, 3ème, 4ème	Stift 1, 2, 3, 4	Perno horquilla 1°, 2°, 3°, 4°,	
	14	8000 26134	1	Forcella ing.1ª e 4ª vel. A.S.	Fork gear shifter 1st, 4th	Fourch 1ère, 4ème	Schaltgabelachse 1,4	Horquilla engr. 1°, 4° vel.	
	15	8000 35119	1	Forcella ing. 2ª e 3ª vel. A.S.	Fork gear shifter 2st, 3th	Fourche 2ère, 3ème	Schaltgabelachse 2, 3	Horquilla engr.2°, 3° vel.	
	16	8000 69253	1	Albero comando forcelle	Fork driving shaft	Arbre de commande fourche	Steuerwelle f. Gabel	Eje mando horquilla	
	17	8000 42677	1	Molla	Spring	Ressort	Feder	Resorte	
	18	8000 42676	1	Puntale	Push rod	Embout	Stösselschaft	Puntal	
	19	8000 44299	1	Perno forcella 5ª e 6ª vel.	Pin 5th and 6th	Pivot 5ème, 6ème	Stift 5., 6.	Perno horquil, 5°, 6° vel.	
	20	8000 33721	1	Forcella ing. 5ª e 6ª vel. A.P.	Fork gear shifter 5th, 6th	Fourch 5ème, 6ème	Schaltgabelachse 5, 6	Horquilla engr. 5° y 6° vel.	
	21	8000 42700	1	Anello OR	O ring	Bague OR	O ring	Anillo OR	
	22	8A00 41682	1	Segnatore folle	Loose transponder	Signaleur	Leerlicht	Senalador	
	23	8000 25254	2	Vite	Screw	Vis	Schraube	Tornillo	
	24	8000 19604	1	Rosetta	Washer	Rondelle	Scheibe	Arandela	
	25	66NO 21203	1	Anello elastico	Split ring	Anneau ressort	Sprengring	Anillo elástico	
	26	8000 66174	1	Pedale cambio	Pedal	Pedale	Pedal	Pedale	
	27	8000 62636	1	Manicotto	Sleeve	Manchon	Muffe	Manguito	
	28	80A0 53548	1	Perno	Pin	Pivot	Bolzen	Perno	
	29	8000 59485	1	Rondella	Washer	Rondelle	Scheibe	Arandela	
	30	8000 01199	2	Anello di tenuta	Seal ring	Bague d'étanchéité	Dichtungsring	Anillo de retención	
	31	8000 60686	1	Astina	Control rod	Coulisseau	Steuerstange	Varilla	

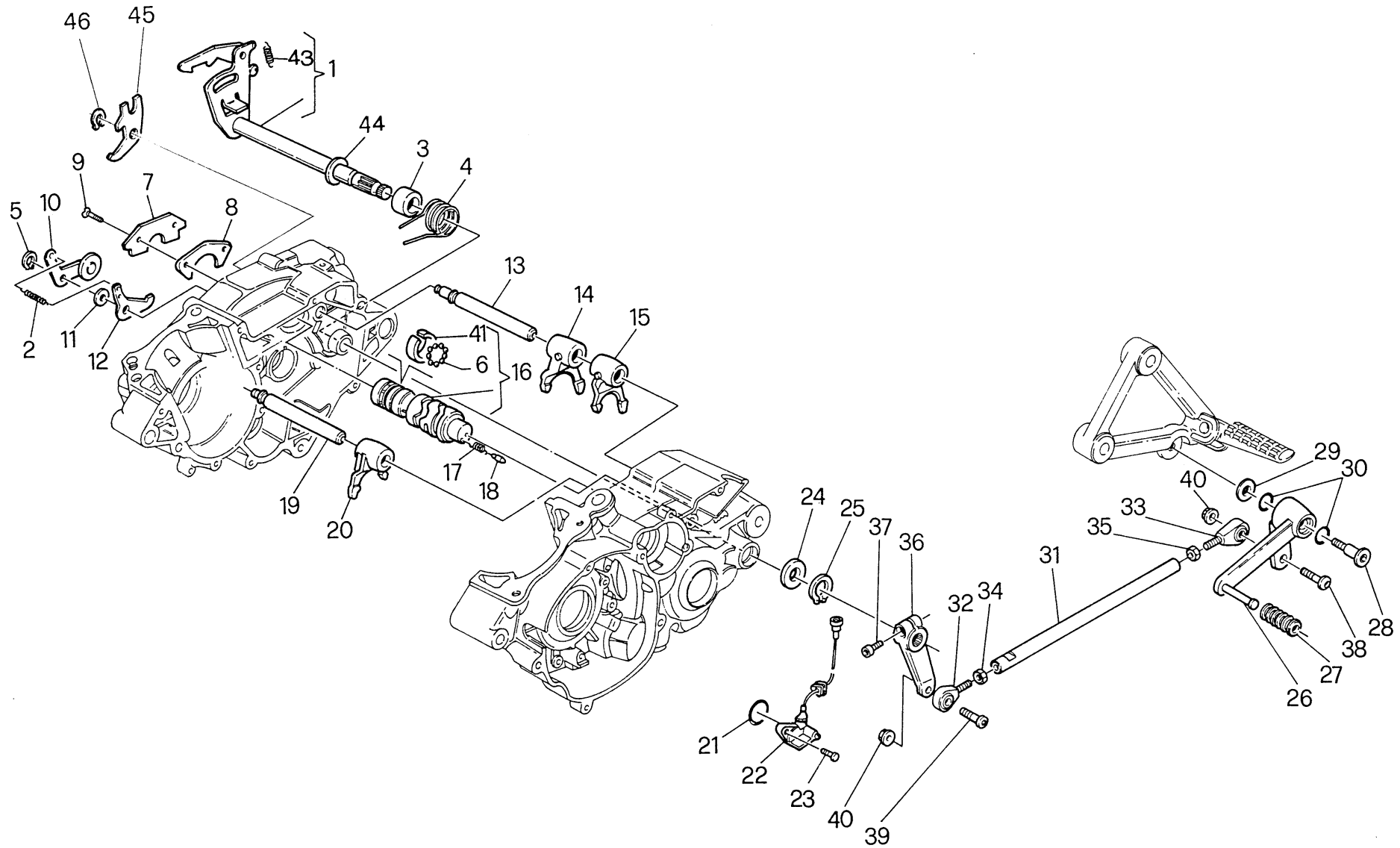

**COMANDO CAMBIO - SHIFTER  
 COMMANDE DE VITESSE - GANGSCHALTUNG  
 MANDO CAMBIO**

Note Notes Marke Notas	Pos. No. Index Pos.	N. Cod. Code No. Nr. Code Code Nr N. Cod.	Q.tà Q.ty Q.te M.ge C.ad	DENOMINAZIONE	NAME	DESIGNATION	BESHREIBUNG	DENOMINACION	Validità Validity Validité Gültig Valides
	32	8000 76055	1	Snodo sferico sx	Ball joint	Joint a rotule	Kugelgelenk	Articulación esférica	
	33	8A00 76055	1	Snodo sferico dx	Ball joint	Joint a rotule	Kugelgelenk	Articulación esférica	
	34	8000 56459	1	Dado	Nut	Ecrou	Mutter	Tuerca	
	35	61N1 15062	1	Dado	Nut	Ecrou	Mutter	Tuerca	
	36	8000 60684	1	Leva	Lever	Levier	Lasche	Palanca	
	37	8G00 90425	1	Vite	Screw	Vis	Schraube	Tornillo	
	38	8000 61070	1	Vite	Screw	Vis	Schraube	Tornillo	
	39	8000 61070	1	Vite	Screw	Vis	Schraube	Tornillo	
	40	8000 44240	2	Dado	Nut	Ecrou	Mutter	Tuerca	
	41	8000 61260	1	Anello elastico	Split ring	Anneau ressort	Sprengring	Anillo elástico	
	43	8000 27103	1	Molla	Spring	Ressort	Feder	Resorte	
	44	8A00 09408	1	Rosetta	Washer	Rondelle	Scheibe	Arandela	
	45	8000 24856	1	Piastrina	Plate	Plaque	Platte	Placa	
	46	8000 21375	1	Anello elastico	Split ring	Anneau ressort	Sprengring	Anillo elástico	

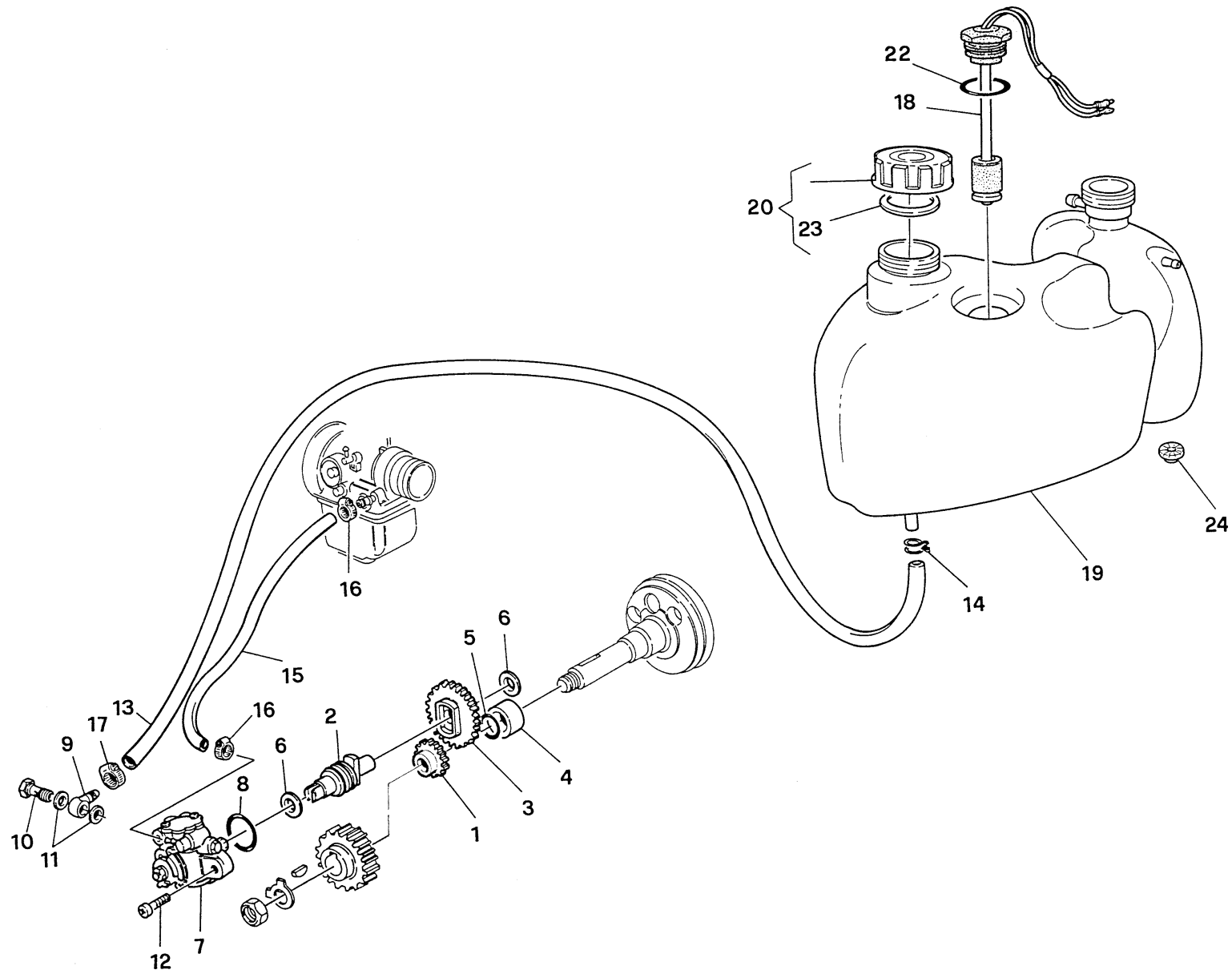

Note Notes Notas	Pos. No. Index Pos.	N. Cod. Code No. Nr. Code Code Nr N. Cod.	Q.tà Q.ty Q.te M.ge C.ad	DENOMINAZIONE	NAME	DESIGNATION	BESHREIBUNG	DENOMINACION	Validità Validity Validité Gültig Valides
	1	8000 92027	1	Pignone pompa olio z= 21	Pinion	Pignon	Ritzel	Piñón	
	2	8000 51662	1	Albero di rinvio	Lay shaft	Arbre renvoi	Vorgelegewelle	Eje reenvío	
	3	8000 51660	1	Ingran. com. pompa z= 42	Pump gear	Engrenage pompe	Zahnrad f. Pumpe	Engranaje com. bomba	
	4	8000 47667	1	Distanziale	Spacer	Entretoise	Distanzstück	Separador	
	5	8000 26884	1	Anello OR per detto	O Ring	Bague OR	O Ring	Anillo OR	
	6	8000 33270	2	Rosetta di rasamento per ingr.	Washer	Rondelle	Scheibe	Arandela	
	7	8000 52129	1	Pompa olio	Oil pump	Pompe à huile	Ölpumpe	Anillo de retención	
	8	8000 71764	1	Anello di tenuta	Seal ring	Bague d'étanchéité	Dichtungsring	Anillo de retención	
	9	8000 19069	1	Raccordo	Union	Raccord	Anschluss	Empalme	
	10	8000 19070	1	Vite	Screw	Vis	Schraube	Tornillo	
	11	8000 19071	2	Rosetta	Washer	Rondelle	Scheibe	Arandela	
	12	8000 24962	2	Vite	Screw	Vis	Schraube	Tornillo	
	13	8000 68873	1	Condotto	Duct	Conduit	Rohr	Conducto	
	14	8000 64586	1	Fascetta	Clamp	Collier	Schelle	Banda	
	15	8000 33272	1	Condotto	Duct	Conduit	Rohr	Conducto	
	16	8000 33273	2	Fascetta	Clamp	Collier	Schelle	Banda	
	17	8000 49642	1	Fascetta	Clamp	Collier	Schelle	Banda	
	18	8A00 59596	1	Interruttore livello olio	Oil level switch	Interrupteur du niveau d'huile	Schalter Oelstand	Interruptor nivel aceite	
	19	8A00 77910	1	Serbatoio olio acqua	Oil tank	Reservoir huile	Öltank	Depósito aceite	
	20	8000 53717	1	Tappo	Plug	Bouchon	Verschluss	Tapón	
	22	8000 23118	1	Guarnizione OR	"OR" Gasket	Garniture "OR"	O Ring Dichtung	Junta OR	
	23	8000 56722	1	Guarnizione	Gasket	Garniture	Dichtung	Junta	
	24	8000 71414	1	Tampone ritegno serbatoio	Pad	Tampon	Stpfen	Tampòn	

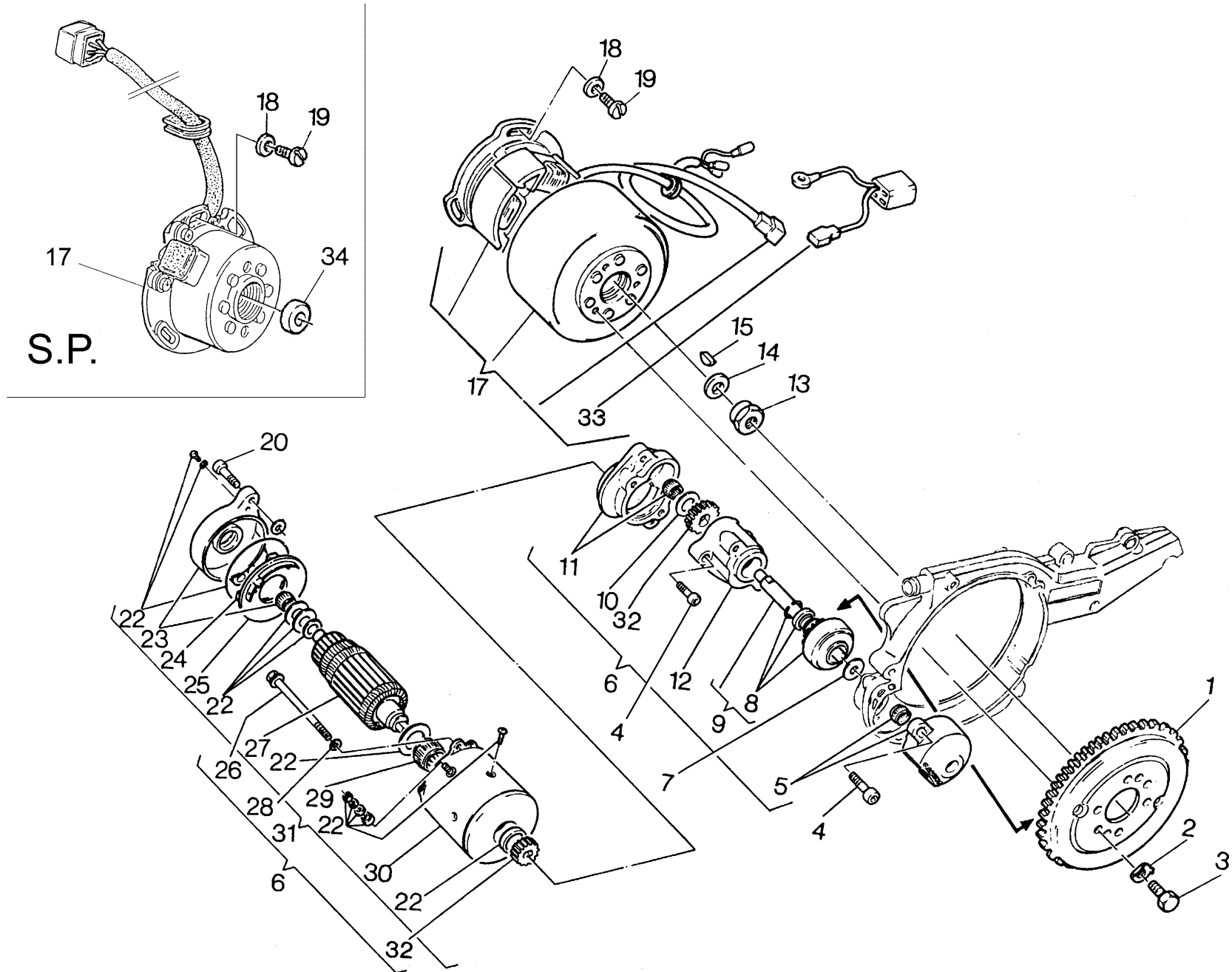



**MOTORINO AVVIAMENTO, ALTERNATORE - ALTERNATOR, STARTING MOTOR  
MOTEUR DE DEMARRAGE, ALTERNATEUR - ALTERNATORANLABMOTOR  
MOTOR DE ARRANQUE, ALTERNADOR**
**(FACIND)**
**TAVOLA  
DRAWING  
TABLE  
BILD  
TABLA**
**11**

Note Notes Marka Notas	Pos. No. Index Pos.	N. Cod. Code No. Nr. Code Code Nr N. Cod.	Q.tà Q.ty Q.te M.ge C.ad	DENOMINAZIONE	NAME	DESIGNATION	BESHREIBUNG	DENOMINACION	Validità Validity Validité Gültig Valides
	1	8000 47374	1	Corona	Soricket	Couronne	Kranz	Corona	
	2	8000 48878	3	Rosetta	Washer	Rondelle	Scheibe	Arandela	
	3	8000 49628	3	Vite	Screw	Vis	Schraube	Tornillo	
	4	60N1 07335	2	Vite	Screw	Vis	Schraube	Tornillo	
	5	8000 50045	1	Coperchio	Cover	Couvercle	Deckel	Tapa	
	6	8000 47373	1	Ass. motorino avv. elettrico	Start motor	Moteur démarrage	Selbstarter	Motor arranque eléctrico	
	7	8G00 31756	1	Rasamento sp. 1 mm.	Thrust	Épaulement	Ausgleich	Rasadura	
	8	8000 47676	1	Serie molla, anello arr.elastico	Kit sprins, seal ring, elastic ring	Kit de ressort, bague d'etan	Kit Feder, Dichtung und elast.	Serie resorte, anillo de suje.	
	9	8000 47675	1	Rinvio completo	Transmission, compl.	Compl. transmission	Vorgelege,Kpl.	Reenvío compl.	
	10	8000 50043	1	Rosetta	Washer	Rondelle	Scheibe	Arandela	
	11	8000 50044	1	Flangia di riduzione compl.	Flange	Bride	Flansch	Brida	
	12	8000 47381	1	Distanziale	Spacer	Entretoise	Distanzstück	Separador	
	13	8000 42023	1	Dado	Nut	Ecrou	Mutter	Tuerca	
	14	8000 66565	1	Rosetta	Washer	Rondelle	Scheibe	Arandela	
	15	65N0 21002	1	Linguetta	Woodruff key	Clé woodruff	Federkeil	Lengüeta	
	17	8000 59030	1	Volano elettronico compl.	Flywheel	Volant	Schwungrad	Volante	
KZ	17	8000 85969	1	Volano elettronico compl.	Flywheel	Volant	Schwungrad	Volante	
	18	62N1 15766	3	Rosetta	Washer	Rondelle	Scheibe	Arandela	
KZ	18	8000 12634	3	Rosetta	Washer	Rondelle	Scheibe	Arandela	
	19	60N1 02901	3	Vite	Screw	Vis	Schraube	Tornillo	
KZ	19	8C00 67997	3	Vite	Screw	Vis	Schraube	Tornillo	
	20	60N1 02509	4	Vite	Screw	Vis	Schraube	Tornillo	
	22	8000 47677	1	Serie rosette e guarnizioni	Washer and gasket kit	Kid de rondelles et Joints	Scheibe und Dichtungskit	Seire arandelas juntas	
	23	8000 47670	1	Supporto	Support	Support	Halterung	Soporte	
	24	8000 51726	2	Spazzole	Brush	Balai	Kohlen	Escobillas	
	25	8000 47672	1	Portaspazzole con molla	Brusch holder	Porte balai	Bürstenhalter	Porta escobillas con resortes	
	26	8000 47679	2	Tirante	Tie rod	Tirant	Spannstange	Tirante	
	27	8000 47674	1	Indotto	Armature	Induit	Anker	Inductor	
	28	62N1 15536	2	Rosetta	Washer	Rondelle	Scheibe	Arandela	
	29	8000 50251	1	Cuscinetto a rullini	Needle bearing	Roulement à aiguilles	Nadelkäfig	Cojinete	
	30	8000 47673	1	Campo induttore compl.	Inductor field assy	Champ inducteur compl.	Induktorfeld	Campo inductor compl.	
	31	8000 50042	1	Motorino senza rinvii	Start motor	Moteur démarrage	Selbstarter	Motor de arranque sin reenvíos	
	32	8000 65575	1	Coppia ingranaggio rinvio	Twing idle gears with spring ring	Couple d'engrenage de	Vorgelegeraderpaar mit	Par engranaje trasmisión	

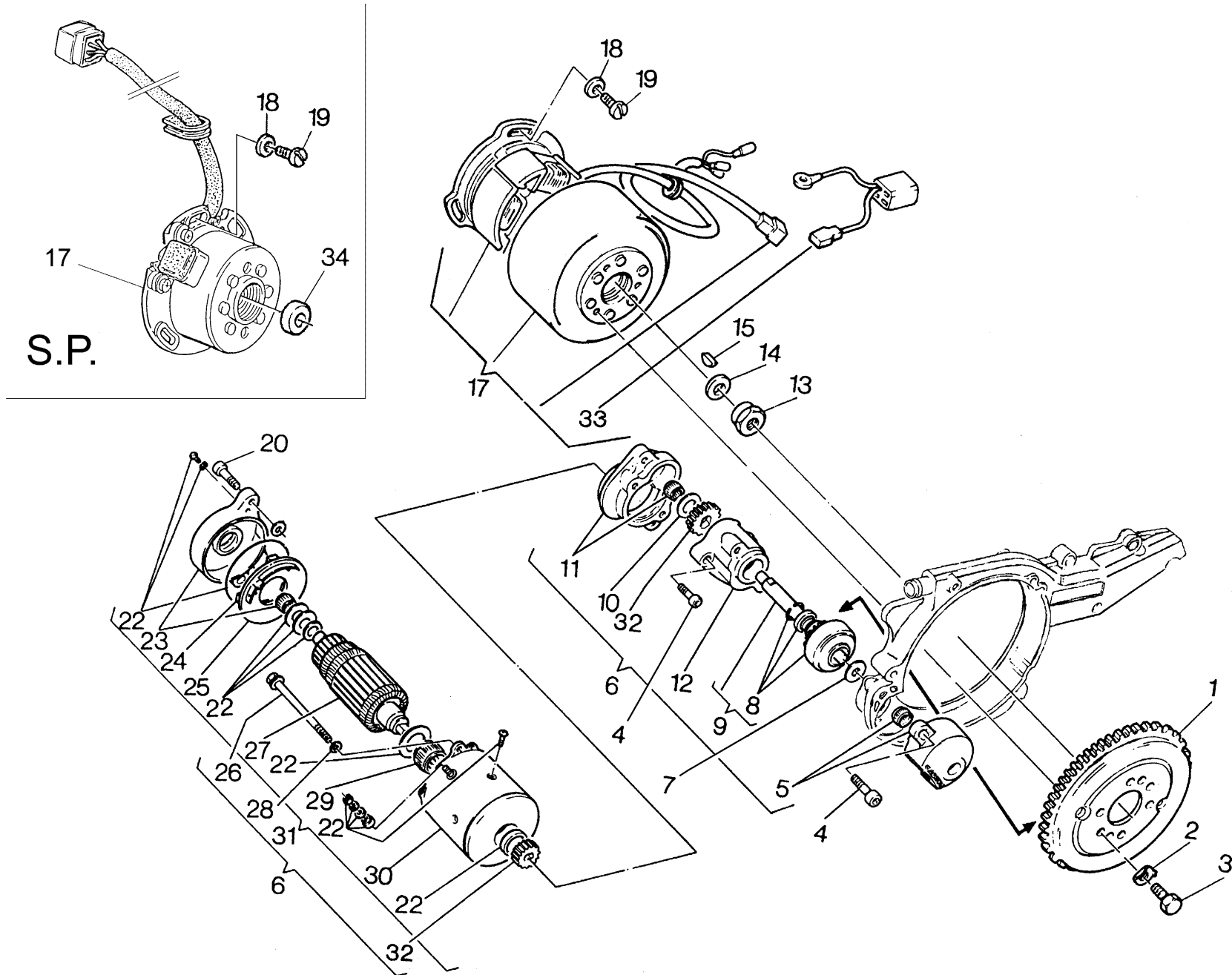

**MOTORINO AVVIAMENTO, ALTERNATORE - ALTERNATOR, STARTING MOTOR  
MOTEUR DE DEMARRAGE, ALTERNATEUR - ALTERNATORANLAßMOTOR  
MOTOR DE ARRANQUE, ALTERNADOR**

(FACIND)

**TAVOLA  
DRAWING  
TABLE  
BILD  
TABLA****11**

Note Notes Marke Notas	Pos. No. Index Pos.	N. Cod. Code No. Nr. Code Code Nr N. Cod.	Q.tà Q.ty Q.te M.ge C.ad	DENOMINAZIONE	NAME	DESIGNATION	BESHREIBUNG	DENOMINACION	Validità Validity Validité Gültig Valides
	33	8000 66550	1	Cavo volano centralina	Cable	Cable	Kabel	Cable	
KZ	34	8000 85791	1	Distanziale	Spacer	Entretoise	Distanzstück	Separador	
K				A richiesta per kit S.P. '99 cod. 800092789	Upon request for S.P. kit '99 code 800092789	Sur demande pour set S.P. '99 code 800092789	Auf Anfrage für Kit S.P. '99 Code 800092789	Bajo pedido por kit S.P. '99 cod. 800092789	
Z				A richiesta per kit S.P. '01 cod. 800097946	Upon request for S.P. kit '01 code 800097946	Sur demande pour set S.P. '01 code 800092789	Auf Anfrage für Kit S.P. '01 Code 800097946	Bajo pedido por kit S.P. '01 cod. 800097946	

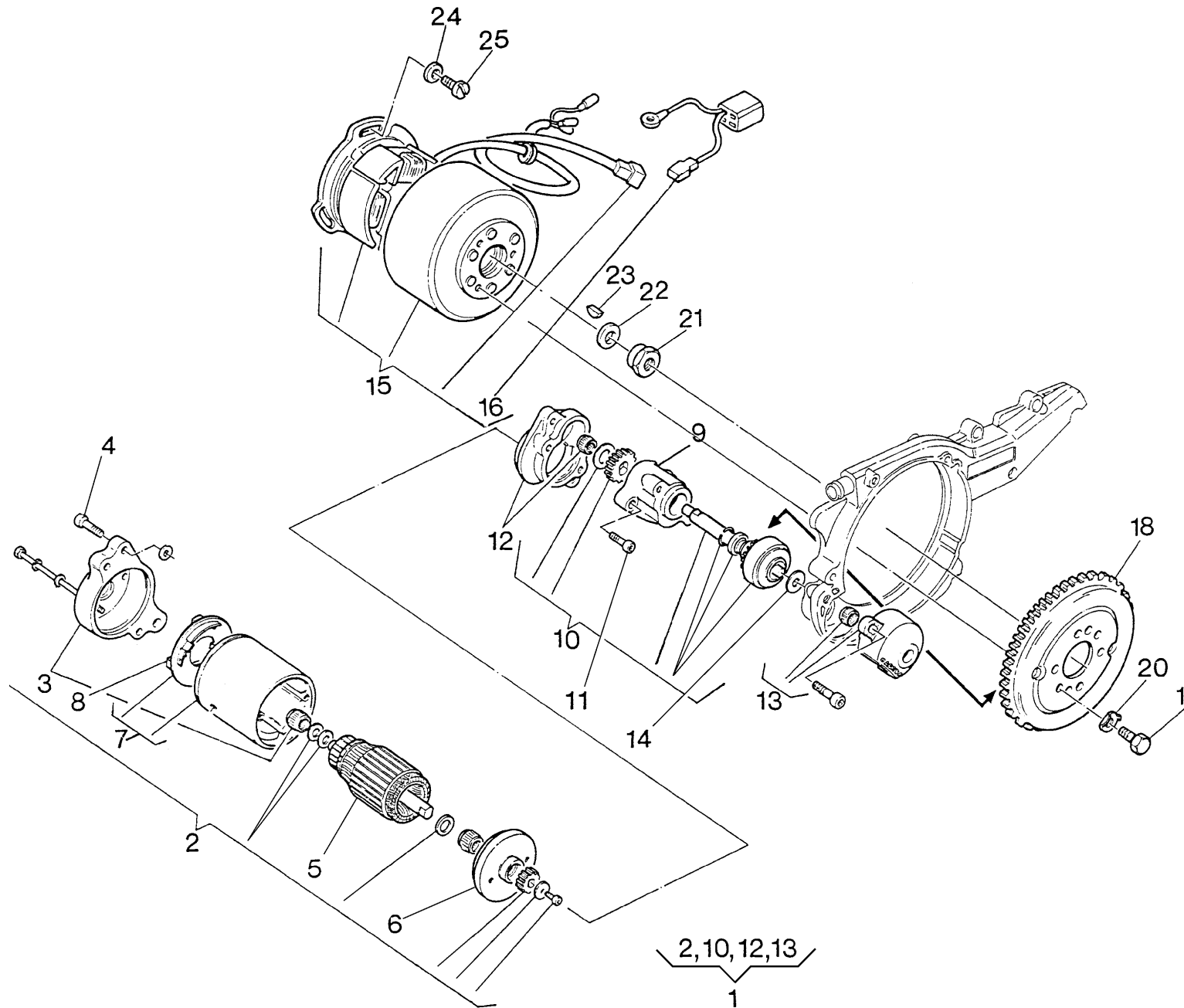

Note Notes Marken Notas	Pos. No. Index Pos.	N. Cod. Code No. Nr. Code Code Nr N. Cod.	Q.tà Q.ty M.ge C.ad	DENOMINAZIONE	NAME	DESIGNATION	BESHREIBUNG	DENOMINACION	Validità Validity Validité Gültig Valides
	1	8000 75398	1	Ass. motorino avv. elettrico	Start motor assy	Moteur démarrage compl.	Selbstarter	Motor arranque eléctrico	
	2	8000 75399	1	Motorino senza rinvii	Start motor	Moteur démarrage	Selbstarter	Motor de arranque sin reenvíos	
	3	8000 75400	1	Calotta	Cover	Couvercle	Haube	Cassquete	
	4	60N1 02509	4	Vite	Screw	Vis	Schraube	Tornillo	
	5	8000 75402	1	Indotto	Armature	Induit	Anker	Inductor	
	6	8000 75403	1	Flangia	Flange	Bride	Flansch	Brida	
	7	8000 75404	1	Tubo statorico completo	Pipe	Tuyau	Rohr	Tubo	
	8	8000 75407	2	Spazzole	Brusch	Balai	Kohlen	Escobillas	
	9	8000 47381	1	Distanziale	Spacer	Entretoise	Distanzstück	Separator	
	10	8000 75405	1	Gruppo pignone	Pinion assy	Plgnon compl.	Ritzel	Pinòn	
	11	60N1 07335	2	Vite	Screw	Vis	Schraube	Tornillo	
	12	8000 50044	1	Flangia	Flange	Bride	Flansch	Brida	
	13	8000 50045	1	Coperchio	Cover	Couvercle	Deckel	Tapa	
	14	8G00 31756	1	Rasamento sp. 1,0 mm.	Thrust	Épaulement	Ausgleich	Rasadura	
	15	8000 59030	1	Volano elettronico compl.	Flywheel	Volant	Schwungrad	Volante	
	16	8000 66550	1	Cavo volano centralina	Cable	Cable	Kabel	Cable	
	18	8000 47374	1	Corona	Soricket	Couronne	Kranz	Corona	
	19	8000 49628	3	Vite	Screw	Vis	Schraube	Tornillo	
	20	8000 48878	3	Rosetta	Washer	Rondelle	Scheibe	Arandela	
	21	8000 42023	1	Dado	Nut	Ecrou	Mutter	Tuerca	
	22	8000 66565	1	Rosetta	Washer	Rondelle	Scheibe	Arandela	
	23	65N0 21002	1	Linguetta	Woodruff key	Clé woodruff	Federkeil	Lengüeta	
	24	62N1 15766	3	Rosetta	Washer	Rondelle	Scheibe	Arandela	
	25	60N1 02901	3	Vite	Screw	Vis	Schraube	Tornillo	

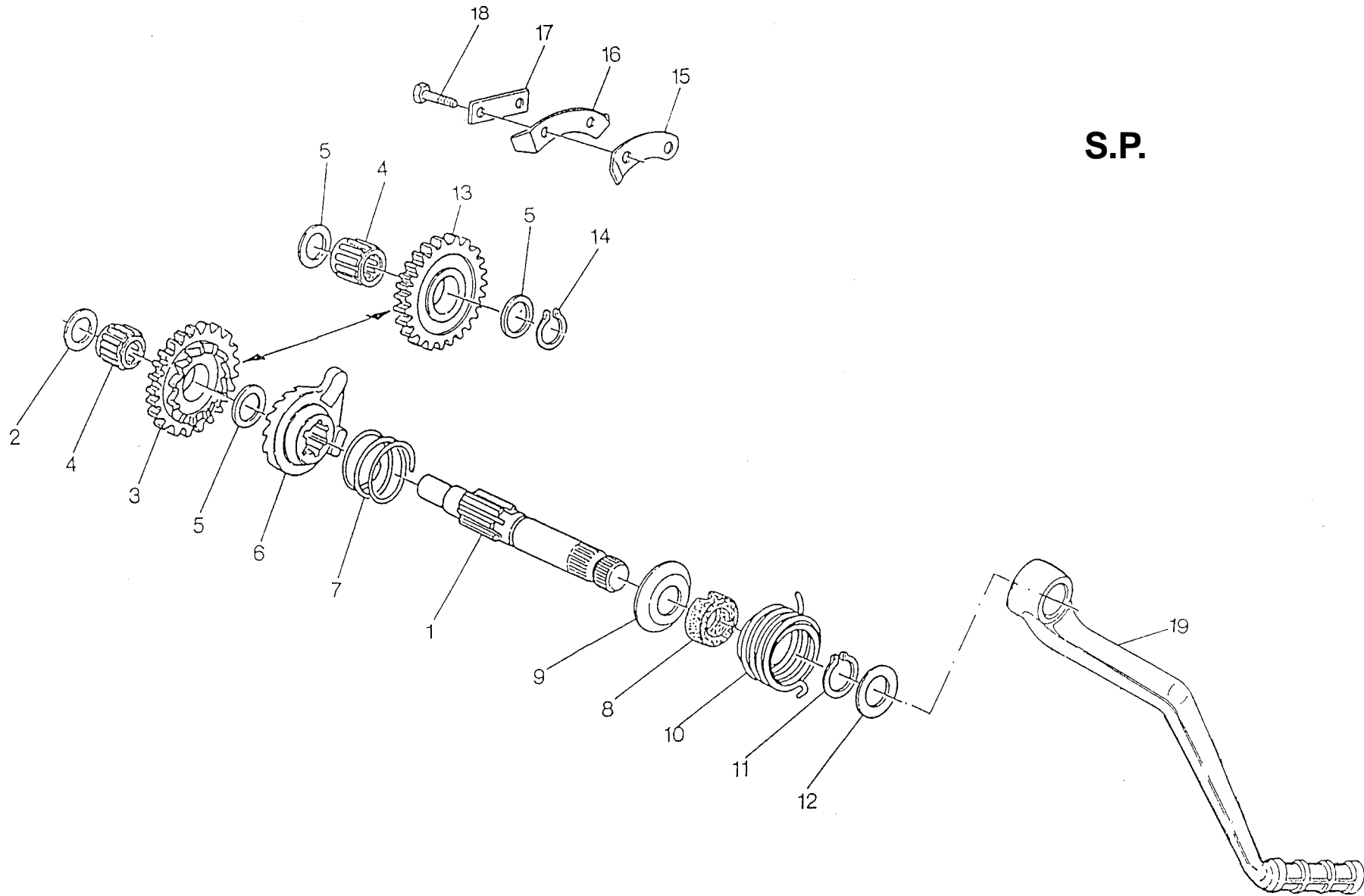

S.P.

Note Notes Marke Notas	Pos. No. Index Pos.	N. Cod. Code No. Nr. Code Code Nr N. Cod.	Q.tà Q.ty Q.te M.ge C.ad	DENOMINAZIONE	NAME	DESIGNATION	BESHREIBUNG	DENOMINACION	Validità Validity Validité Gültig Valides
	1	8000 36379	1	Albero comando avviamento	Starter crank shaft	Arbre de démarrage	Kickstarterwelle	Eje arranque	
	2	8G00 04551	1	Rosetta di rasam. sp. 1,0 mm	Thrust washer	Rondelle d'épaulement	Anlaufscheibe	Arandela	
	3	8000 42284	1	Ingranaggio	Gear	Engrenage	Zahnrad	Engranaje	
	4	8000 22375	2	Cuscinetto a rullini	Needle bearing	Roulement à aiguilles	Nadelkafig	Cojinete de rodillos	
	5	8D00 04553	3	Rosetta di rasam. sp. 0,6 mm	Thrust washer	Rondelle d'épaulement	Anlaufscheibe	Arandela	
	6	8000 24905	1	Manicotto scorrevole	Sliding boot	Manchon	Muffe	Manguito	
	7	8000 31762	1	Molla	Spring	Ressort	Feder	Resorte	
	8	8000 31763	1	Distanziale	Spacer	Entretoise	Distanzstück	Separador	
	9	8000 57660	1	Rosetta di rasamento	Thrust washer	Rondelle d'épaulement	Anlaufscheibe	Arandela	
	10	8000 31764	1	Molla	Spring	Ressort	Feder	Resorte	
	11	66N0 21206	1	Anello seeger	Circlip	Bague d'arret	Federring	Anillo seeger	
	12	8G00 10904	1	Rosetta di rasam. sp. 1,0 mm	Thrust washer	Rondelle d'épaulement	Anlaufscheibe	Arandela	
	13	8000 42282	1	Ingranaggio	Gear	Engrenage	Zahnrad	Engranaje	
	14	66N0 21204	1	Anello seeger	Circlip	Bague d'arret	Federring	Anillo seeger	
	15	8000 31695	1	Piastrina	Plate	Plaque	Platte	Placa	
	16	8000 31696	1	Piastrina	Plate	Plaque	Platte	Placa	
	17	8000 20474	1	Piastrina	Plate	Plaque	Platte	Placa	
	18	60N1 01081	2	Vite	Screw	Vis	Schraube	Tornillo	
	19	8000 78714	1	Leva avviamento compl.	Starter lever assy	Levier démarrage compl.	Hebelanlasser kpl.	Palanca arranque compl.	

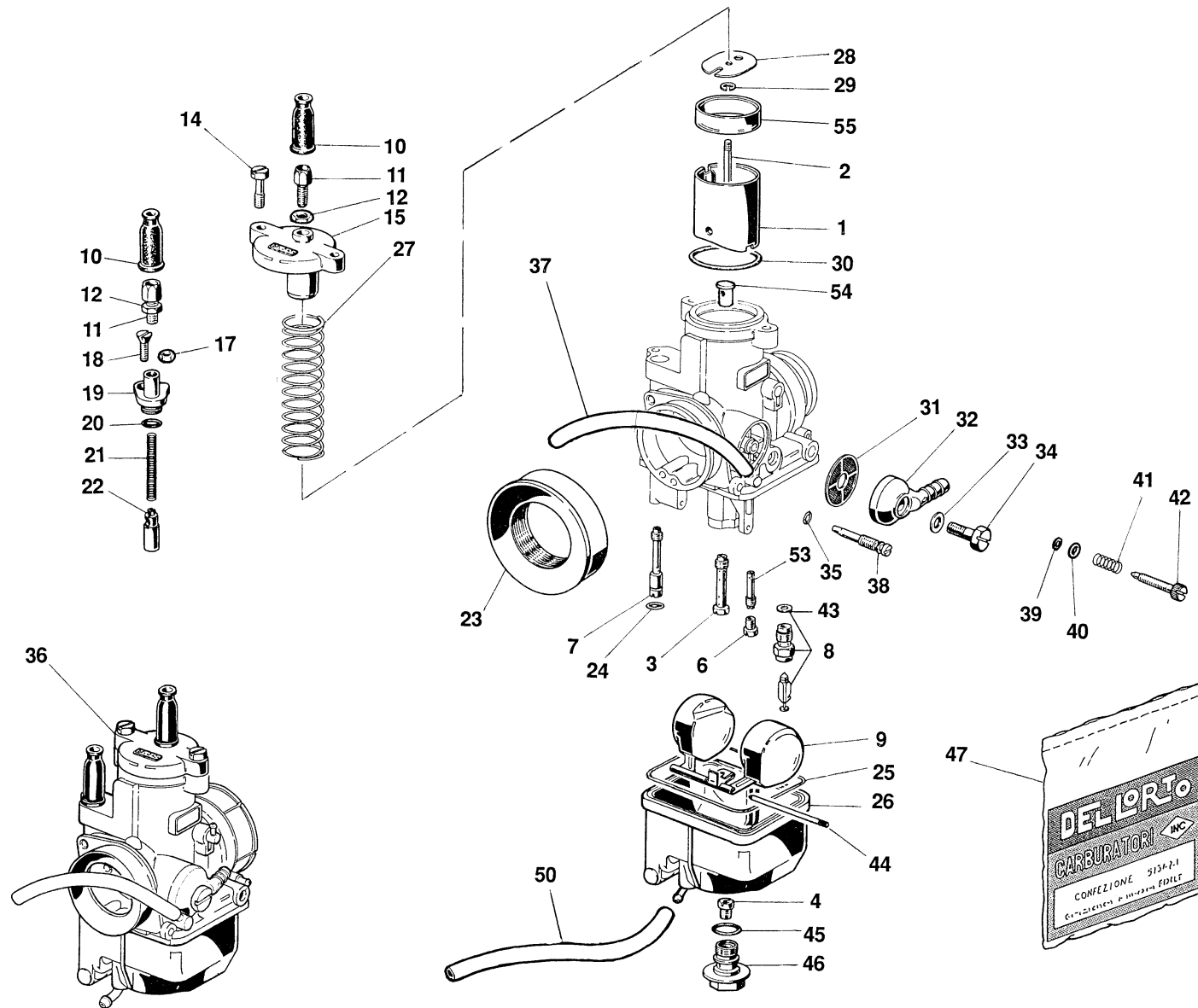



Note Notes Marken Notas	Pos. No. Index Pos.	N. Cod. Code No. Nr. Code Code Nr N. Cod.	Q.tà Q.ty Q.te M.ge C.ad	DENOMINAZIONE	NAME	DESIGNATION	BESHREIBUNG	DENOMINACION	Validità Validity Validité Gültig Valides
	1	80D0 36681	1	Valvola gas da 45	Throttle valve	Soupape gaz	Drosselkappe	Válvula	
KZ	1	80C0 36681	1	Valvola gas da 50	Throttle valve	Soupape gaz	Drosselkappe	Válvula	
	2	80S0 36683	1	Spillo conico 3° tacca	Needle	Pointeau conique	Kon. Nadel	Pasador cónico	
	3	8A00 49525	1	Polverizzatore BN 270	Fuel nozzle	Pulvérisateur	Einspritzdüse	Pulverizador	
KZ	3	8C00 49525	1	Polverizzatore BN 272	Fuel nozzle	Pulvérisateur	Einspritzdüse	Pulverizador	
KZ	3	8D00 49525	1	Polverizzatore BN 274	Fuel nozzle	Pulvérisateur	Einspritzdüse	Pulverizador	
KZ	3	8E00 49525	1	Polverizzatore BN 276	Fuel nozzle	Pulvérisateur	Einspritzdüse	Pulverizador	
KZ	3	8F00 49525	1	Polverizzatore BN 278	Fuel nozzle	Pulvérisateur	Einspritzdüse	Pulverizador	
Q	3	8D00 49525	1	Polverizzatore BN 274 ( BR )	Fuel nozzle ( BR )	Pulvérisateur ( BR )	Einspritzdüse ( BR )	Pulverizador ( BR )	
	4	8AB0 12041	1	Getto massimo 100	Main jet	Gicleur principal	Hauptdüse	Chiclé máximo	
KZ	4	80G0 12041	1	Getto massimo 125	Main jet	Gicleur principal	Hauptdüse	Chiclé máximo	
KZ	4	80H0 12041	1	Getto massimo 128	Main jet	Gicleur principal	Hauptdüse	Chiclé máximo	
KZ	4	80I0 12041	1	Getto massimo 130	Main jet	Gicleur principal	Hauptdüse	Chiclé máximo	
KZ	4	8BE0 12041	1	Getto massimo 132	Main jet	Gicleur principal	Hauptdüse	Chiclé máximo	
KZ	4	80N0 12041	1	Getto massimo 135	Main jet	Gicleur principal	Hauptdüse	Chiclé máximo	
KZ	4	8AD0 12041	1	Getto massimo 140	Main jet	Gicleur principal	Hauptdüse	Chiclé máximo	
P	4	80E0 12041	1	Getto massimo 120	Main jet	Gicleur principal	Hauptdüse	Chiclé máximo	
Q	4	80E0 12041	1	Getto massimo 120	Main jet	Gicleur principal	Hauptdüse	Chiclé máximo	
				<b>(AUS - INA - MAL - ZA)</b>	<b>(AUS - INA - MAL - ZA)</b>	<b>(AUS - INA - MAL - ZA)</b>	<b>(AUS - INA - MAL - ZA)</b>	<b>(AUS - INA - MAL - ZA)</b>	
Q	4	80N0 12041	1	Getto massimo 135 ( BR )	Main jet ( BR )	Gicleur principal ( BR )	Hauptdüse ( BR )	Chiclé máximo ( BR )	
	6	8D00 87148	1	Getto minimo 55	Idle jet	Gicleur minimum	Leerlaufdüse	Chiclé mínimo	
P	6	8C00 87148	1	Getto minimo 65	Idle jet	Gicleur minimum	Leerlaufdüse	Chiclé mínimo	
Q	6	8B00 87148	1	Getto minimo 60 ( BR )	Idle jet ( BR )	Gicleur minimum ( BR )	Leerlaufdüse ( BR )	Chiclé mínimo ( BR )	
Q	6	8C00 87148	1	Getto minimo 65	Idle jet	Gicleur minimum	Leerlaufdüse	Chiclé mínimo	
				<b>(AUS - INA - MAL - ZA)</b>	<b>(AUS - INA - MAL - ZA)</b>	<b>(AUS - INA - MAL - ZA)</b>	<b>(AUS - INA - MAL - ZA)</b>	<b>(AUS - INA - MAL - ZA)</b>	
	7	80F0 12032	1	Getto avviamento 65	Starting jet	Gicleur de starter	Starterdüse	Chiclé arranque	
	8	8000 33109	1	Valvola a spillo 300	Needle valve	Soupape à pointeau	Nadelventil	Válvula de aguja	
	9	80C0 35357	1	Galleggiante g 9,5	Float	Flotteur	Schwimmer	Flotador	
	11	8000 87563	2	Vite	Screw	Vis	Schraube	Tornillo	
	12	8000 51987	2	Dado	Nut	Ecrou	Mutter	Tuerca	
	14	8000 23981	2	Vite	Screw	Vis	Schraube	Tornillo	
	15	8000 36685	1	Coperchio valvola gas	Throttle valve cover	Couvercle papillon de gaz	Drosselkappe Deckel	Tapa válvula acelerador	
	17	8000 04104	1	Dado	Nut	Ecrou	Mutter	Tuerca	

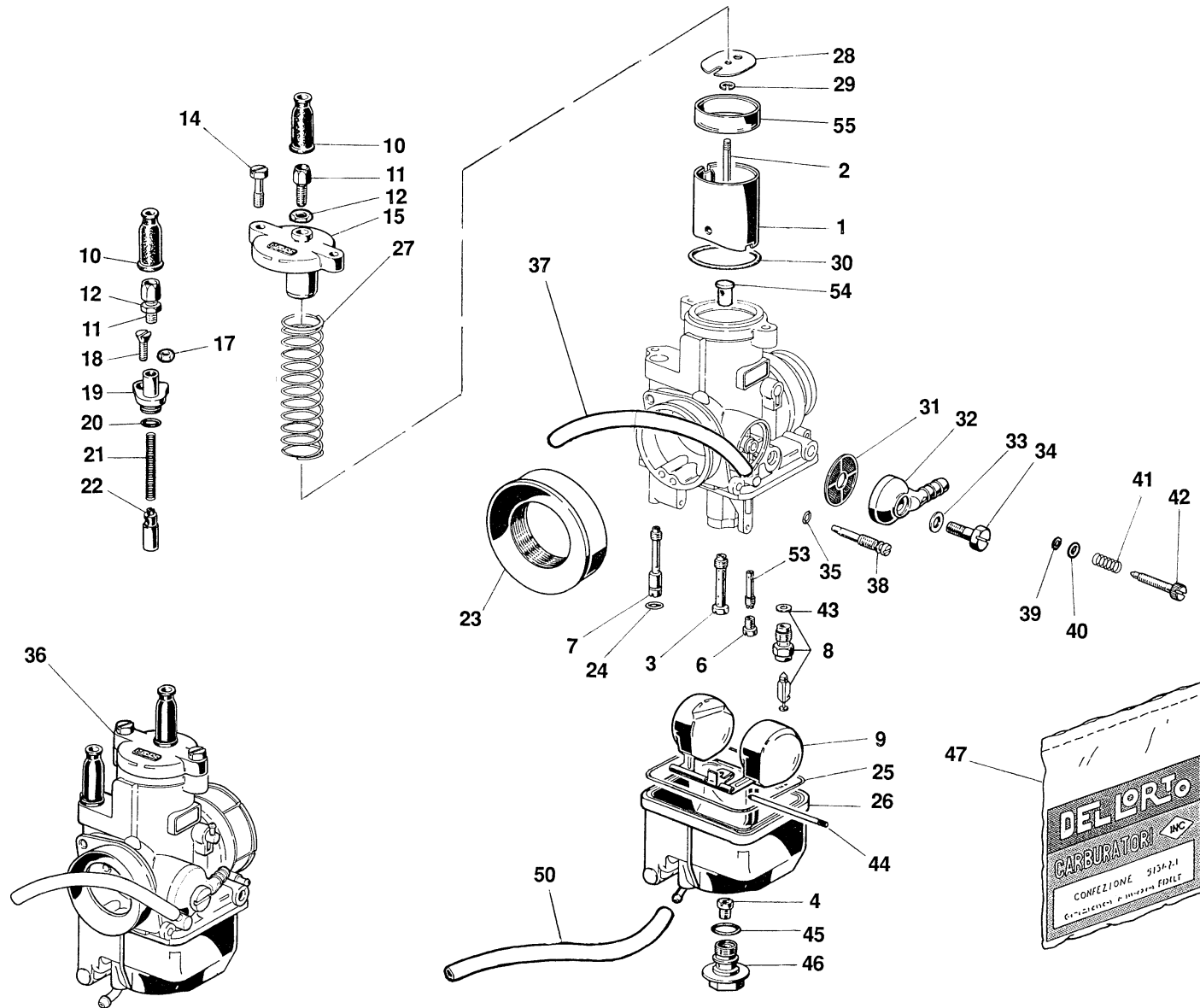

Note Notes Marka Notas	Pos. No. Index Pos.	N. Cod. Code No. Nr. Code Code Nr N. Cod.	Q.tà Q.ty Q.te M.ge C.ad	DENOMINAZIONE	NAME	DESIGNATION	BESHREIBUNG	DENOMINACION	Validità Validity Validité Gültig Valides
	18	8000 32855	1	Vite	Screw	Vis	Schraube	Tornillo	
	19	8000 40582	1	Coperchio	Cover	Couvercle	Deckel	Tapa	
	20	I	1	Guarnizione dispos. avv.	Gasket	Garniture	Dichtung	Junta	
	21	8000 44043	1	Molla	Spring	Ressort	Feder	Resorte	
	22	8000 40580	1	Valvola avviamento	Starter valve	Soupape de démarrage	Startventil	Válvula	
	23	8000 36687	1	Raccordo	Union	Raccord	Anschluss	Empalme	
	24	I	1	Guarnizione getto avviamento	Gasket	Garniture	Dichtung	Junta	
	25	I	1	Guarnizione vaschetta	Gasket	Garniture	Dichtung	Junta	
	26	8000 79936	1	Vaschetta	Chamber	Cuvette	Becken	Cubeta	
	27	8000 35086	1	Molla	Spring	Ressort	Feder	Resorte	
	28	8000 36682	1	Piastrina	Plate	Plaque	Plättchen	Placa	
	29	8000 35353	1	Fermaglio spillo conico	Retainer	Arret	Klammer	Pasador cónico	
	30	I	1	Guarnizione coperchio	Gasket	Garniture	Dichtung	Junta tapa válvulas	
	31	8000 12045	1	Filtro benzina	Fuel filter	Filtre essence	Benzinfilter	Filtro gasolina	
	32	8000 57436	1	Pipetta	Pipette	Pipette	Pipette	Pipa	
	33	I	1	Guarnizione vite	Gasket	Garniture	Dichtung	Junta	
	34	8000 57437	1	Vite	Screw	Vis	Schraube	Tornillo	
	35	I	1	Guarnizione vite	Gasket	Garniture	Dichtung	Junta	
	36	8000 91813	1	Assieme carburatore	Carburetor assy	Carbureteur complet	Vegaser, kpl.	Carburador compl.	
Q	36	8000 A1062	1	Assieme carburatore (AUS - INA - MAL - ZA)	Carburetor assy (AUS - INA - MAL - ZA)	Carbureteur complet (AUS - INA - MAL - ZA)	Vegaser, kpl. (AUS - INA - MAL - ZA)	Carburador compl. (AUS - INA - MAL - ZA)	
	37	8A00 55507	2	Tubetto	Pipe	Tuyau	Rohr	Tubo	
	38	8000 64169	1	Vite	Screw	Vis	Schraube	Tornillo	
	39	I	1	Guarnizione vite	Gasket	Garniture	Dichtung	Junta	
	40	8000 23983	1	Rondella piana	Washer	Rondelle	Unterlegscheibe	Arandela plana	
	41	8000 12030	1	Molla	Spring	Ressort	Feder	Resorte	
	42	8000 12029	1	Vite	Screw	Vis	Schraube	Tornillo	
	43	I	1	Guarnizione valvola a spillo	Gasket	Garniture	Dichtung	Junta	
	44	8000 12037	1	Perno galleggiante	Pin	Pivot	Bolzen	Perno	
	45	I	1	Guarnizione tappo	Gasket	Garniture	Dichtung	Junta	
	46	8000 49531	1	Tappo	Plug	Bouchon	Verschluss	Tapòn	
	47	8000 64170	1	Gruppo guarnizioni	Gasket set	Groupe garniture	Dichtungssatz	Grupo junta	
	49	8000 21810	1	Fascetta	Clamp	Collier	Schelle	Banda	

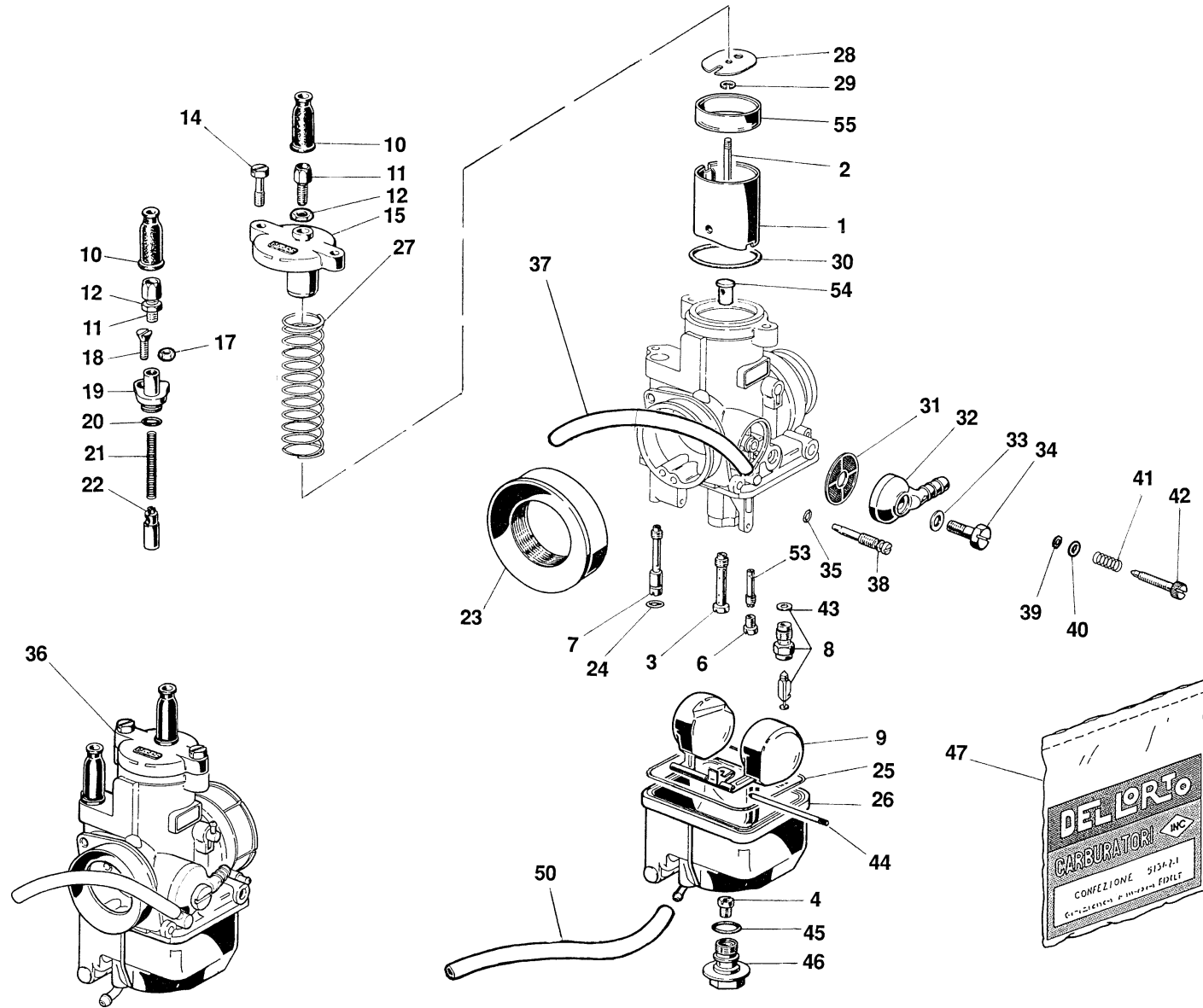

Note Notes Mark Notas	Pos. No. Index Pos.	N. Cod. Code No. Nr. Code Code Nr N. Cod.	Q.tà Q.ty M.ge C.ad	DENOMINAZIONE	NAME	DESIGNATION	BESHREIBUNG	DENOMINACION	Validità Validity Validité Gültig Valides
	50	8D00 55507	1	Tubo scarico benzina	Pipe	Tuyau	Rohr	Tubo	
	52	I	1	Guarnizione	Gasket	Garnitue	Dichtung	Junta	
	53	80A0 63846	1	Emulsionatore da 55	Emulsifier	Emulsionneur	Mischer	Emulsionador	
P	53	80D0 63846	1	Emulsionatore da 65	Emulsifier	Emulsionneur	Mischer	Emulsionador	
Q	53	80D0 63846	1	Emulsionatore da 65 (AUS - INA - MAL - ZA)	Emulsifier (AUS - INA - MAL - ZA)	Emulsionneur (AUS - INA - MAL - ZA)	Mischer (AUS - INA - MAL - ZA)	Emulsionador (AUS - INA - MAL - ZA)	
	54	8000 87150	1	Ugello polverizzatore	Spry nozzle	Buse atomiseur	Einspritzdüse	Injectòr pulverizadòr	
	55	8000 A0554	1	Distanziale (D)	Spacer (D)	Entretoise (D)	Distanzstück (D)	Separadòr (D)	
K		I		Contenuto in busta guarnizioni (47) A richiesta per kit S.P. '99 cod. 800092789	It's contained in the gasket set (47) Upon request for S.P. kit '99 code 800092789	Contenu en l'enveloppe joints (47) Sur demande pour set S.P. '99 code 800092789	In den reparaturenrichtungssatz (47) Auf Anfrage für Kit S.P. '99 Code 800092789	En el saquito de guarnic. (47) Bajo pedido por kit S.P. '99 cod. 800092789	
Z				A richiesta per kit S.P. '01 cod. 800097946	Upon request for S.P. kit '01 code 800097946	Sur demande pour set S.P. '01 code 800092789	Auf Anfrage für Kit S.P. '01 Code 800097946	Bajo pedido por kit S.P. '01 cod. 800097946	
P				Kit potenziamento N. 800093893	Kit poweri No 800093893	Kit de puissance Nr 800093893	Kit Potenz Nr 800093893	Kit Potencia N. 800093893	
Q				Versione Piena Potenza	Full power version	Vérsion plein puissance	Version Plus Potenz	Vérsion potencia plena	

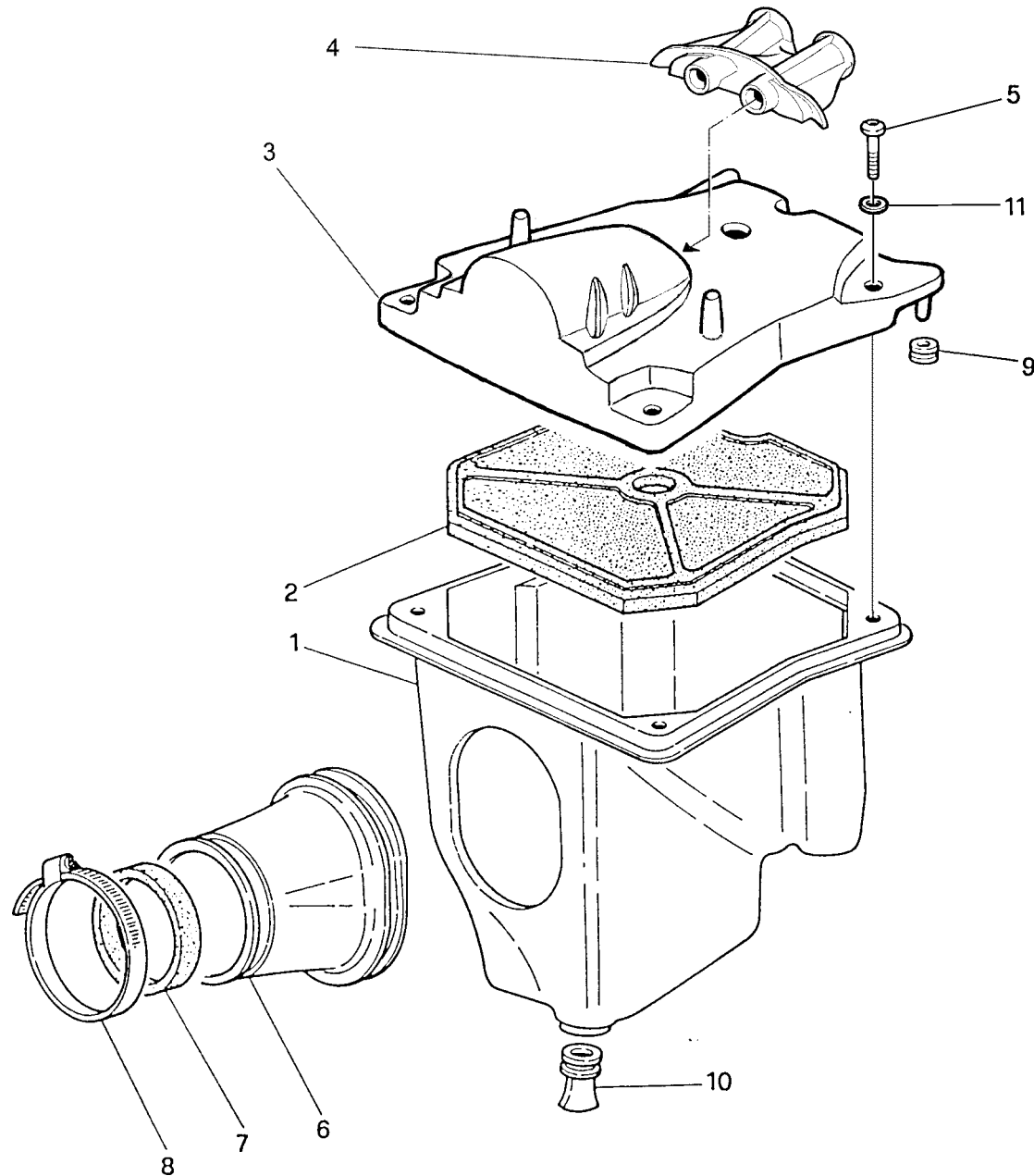

**SCATOLA FILTRO ARIA - AIR FILTER BOX  
BITE FILTRE AIRE - FILTERKASTEN  
CAJA FILTRO AIRE**

Note Notes Marke Notas	Pos. No. Index Pos.	N. Cod. Code No. Nr. Code Code Nr N. Cod.	Q.tà Q.ty Q.te M.ge C.ad	DENOMINAZIONE	NAME	DESIGNATION	BESHREIBUNG	DENOMINACION	Validità Validity Validité Gültig Valides
	1	8000 66506	1	Scatola filtro	Air filter box	Boite pour filtre	Luftfiltergehäuse	Caja Filtro aire	
	2	8000 66507	1	Filtro	Filter	Filtre	Filter	Filtro	
	3	8000 90499	1	Coperchio	Cover	Couvercle	Deckel	Tapa	
	4	8000 92229	1	Manicotto	Sleeve	Manchon	Muffe	Manguito	
P	4	8000 93969	1	Manicotto	Sleeve	Manchon	Muffe	Manguito	
Q	4	8000 93969	1	Manicotto	Sleeve	Manchon	Muffe	Manguito	
				<b>(BR - AUS - INA - MAL - ZA)</b>	<b>(BR - AUS - INA - MAL - ZA)</b>	<b>(BR - AUS - INA - MAL - ZA)</b>	<b>(BR - AUS - INA - MAL - ZA)</b>	<b>(BR - AUS - INA - MAL - ZA)</b>	
	5	8000 62728	4	Vite	Screw	Vis	Schraube	Tornillo	
	6	8000 66510	1	Raccordo	Union	Raccord	Anschluss	Empalme	
	7	8000 67171	1	Anello	Ring	Bague	Ring	Anillo	
	8	8C00 68666	1	Fascetta	Clamp	Collier	Schelle	Banda	
	9	0370 72020	2	Antivibrante	Silent block	Antivibration	Schwingungsdämpfer	Anti vibrador	
	10	8000 48971	1	Gommino	Rubber pad	Pièce caoutchouc	Gummistück	Junta de goma	
	11	8000 04898	4	Rosetta	Washer	Rondelle	Scheibe	Arandela	
P				Kit potenziamento N. 800093893	Kit poweri No 800093893	Kit de puissance Nr 800093893	Kit Potenz Nr 800093893	Kit Potencia N. 800093893	
Q				Versione piena potenza	Full power version	Vérision plein puissance	Version Plus Potenz	Vérision potencia piena	

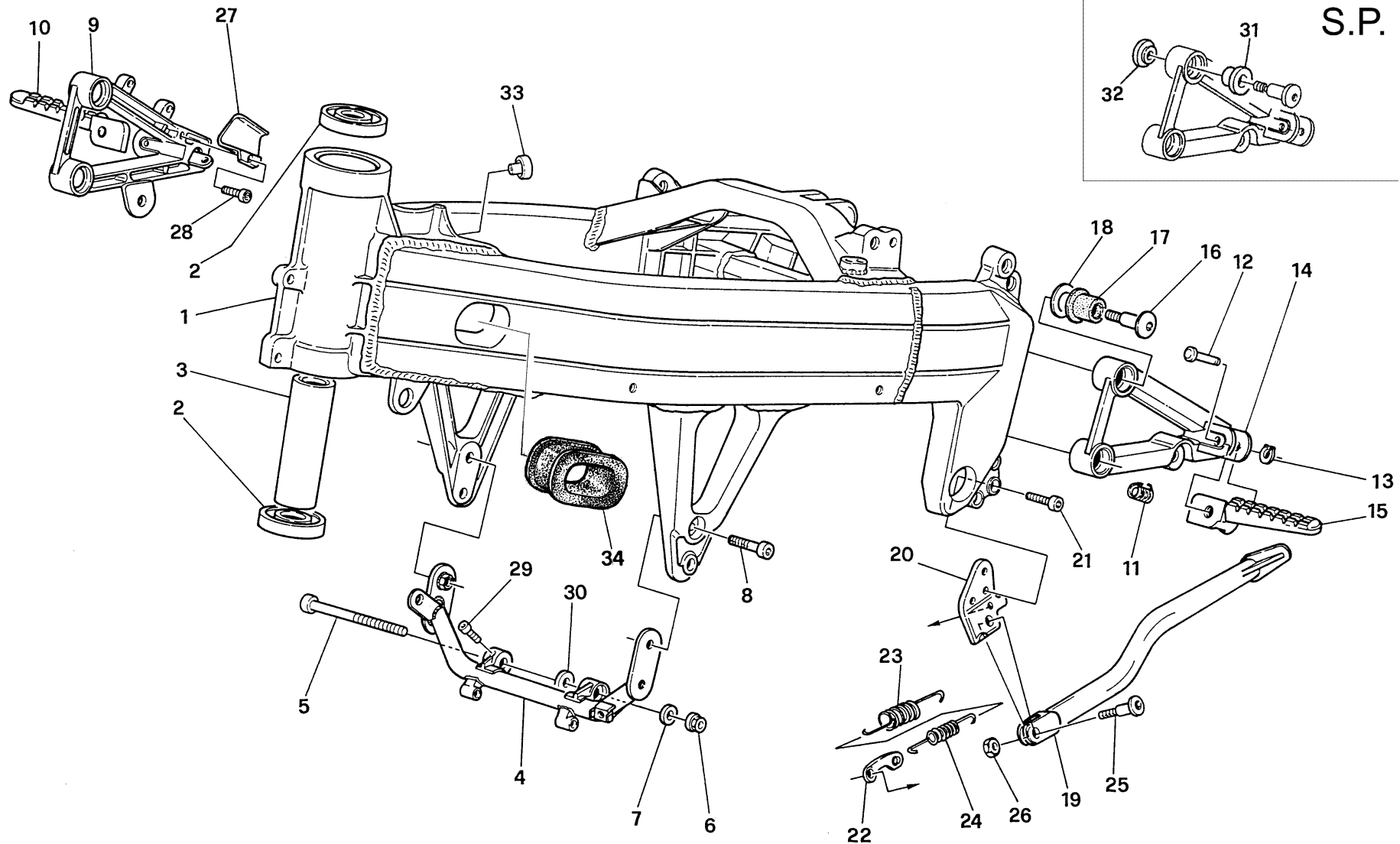



Note Notes Marka Notas	Pos. No. Index Pos.	N. Cod. Code No. Nr. Code Code Nr N. Cod.	Q.tà Q.ty Q.te M.ge C.ad	DENOMINAZIONE	NAME	DESIGNATION	BESHREIBUNG	DENOMINACION	Validità Validity Validité Gültig Valides
	1	8000 77752	1	Assieme telaio	Frame, assy	Cadre complete	Kpl., Rahmen	Bastidor compl.	
	2	8000 22672	2	Cuscinetto	Bearing	Roulement	Lager	Cojinete	
	3	8000 53554	1	Distanziale	Spacer	Entretoise	Distanzstück	Separador	
	4	8AA0 69057	1	Traversino	Cross member	Traverse	Traverse	Travesaño	
	5	8000 67987	1	Vite	Screw	Vis	Schraube	Tornillo	
	6	8000 43928	2	Dado	Nut	Ecrou	Mutter	Tuerca	
	7	8E00 05893	1	Rosetta piana	Washer	Rondelle	Scheibe	Arandela	
	8	8E00 90426	4	Vite	Screw	Vis	Schraube	Tornillo	
	9	8AA0 60685	1	Supporto destro	Support	Support	Halterung	Soporte	
	10	8AA0 62562	1	Pedana anteriore destra	Foot rest	Repose pieds	Fussraste	Pedal delnt. derech. compl.	
	11	8000 60700	2	Molla	Spring	Ressort	Feder	Resorte	
	12	80A0 53546	2	Perno	Pin	Pivot	Bolzen	Perno	
	13	66N1 21308	2	Anello seeger	Seeger ring	Bague seeger	Seegerring	Anillo Seeger	
	14	80A0 60688	1	Supporto sinistro	Support	Support	Halterung	Soporte	
	15	8AA0 62563	1	Pedana anteriore sinistra	Foot rest	Repose pieds	Fussraste	Pedal delnt. derech. compl.	
	16	8000 62568	4	Vite	Screw	Vis	Schraube	Tornillo	
	17	8000 60683	4	Silent block	Silent block	Silent block	Silentblock	Silentblock	
	18	8000 62567	8	Rondella	Washer	Rondelle	Scheibe	Arandela	
	19	8000 60693	1	Gamba laterale	Side stand	Bequille lat.	Seitenständer	Horquilla lateral	
	20	8000 62592	1	Piastra	Plate	Plaque	Platte	Placa	
	21	8E00 90426	3	Vite	Screw	Vis	Schraube	Tornillo	
	22	8000 62644	1	Piastrina	Plate	Plaque	Plättchen	Placa	
	23	8000 62675	1	Molla esterna	Spring	Ressort	Feder	Resorte	
	24	8000 62676	1	Molla interna	Spring	Ressort	Feder	Resorte	
	25	8000 62595	2	Perno	Pin	Pivot	Bolzen	Perno	
	26	8000 43928	1	Dado	Nut	Ecrou	Mutter	Tuerca	
	27	8000 62646	1	Protezione	Guard	Protection	Schutz	Protección	
	28	8000 62725	1	Vite	Screw	Vis	Schraube	Tornillo	
	29	8G00 90426	1	Vite	Screw	Vis	Schraube	Tornillo	
	30	8000 05893	1	Rosetta	Washer	Rondelle	Scheibe	Arandela	
KZ	31	8000 73030	2	Distanziale	Spacer	Entretoise	Distanzstück	Separador	
KZ	32	8000 73031	2	Distanziale	Spacer	Entretoise	Distanzstück	Separador	
	33	8000 78181	1	Tampone	Pad	Tampon	Stpfen	Tampòn	

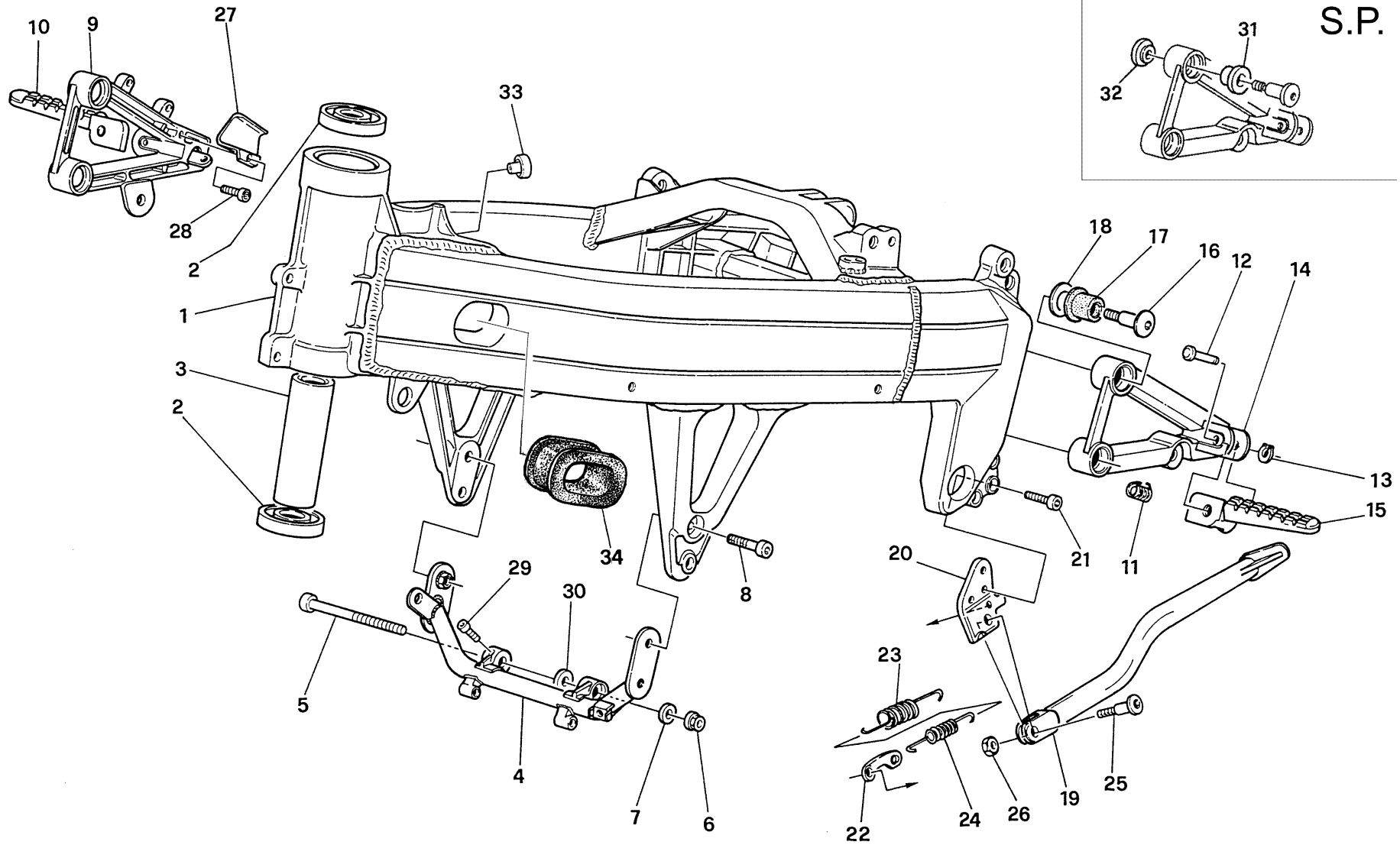

Note Notes Marka Notas	Pos. No. Index Pos.	N. Cod. Code No. Nr. Code Code Nr N. Cod.	Q.tà Q.ty Q.te M.ge C.ad	DENOMINAZIONE	NAME	DESIGNATION	BESHREIBUNG	DENOMINACION	Validità Validity Validité Gültig Valides
	34	8000 67978	1	Manicotto	Sleeve	Manchon	Muffe	Manguito	
K				A richiesta per kit S.P. '99 cod. 800092789	Upon request for S.P. kit '99 code 800092789	Sur demande pour set S.P. '99 code 800092789	Auf Anfrage für Kit S.P. '99 Code 800092789	Bajo pedido por kit S.P. '99 cod. 800092789	
Z				A richiesta per kit S.P. '01 cod. 800097946	Upon request for S.P. kit '01 code 800097946	Sur demande pour set S.P. '01 code 800092789	Auf Anfrage für Kit S.P. '01 Code 800097946	Bajo pedido por kit S.P. '01 cod. 800097946	

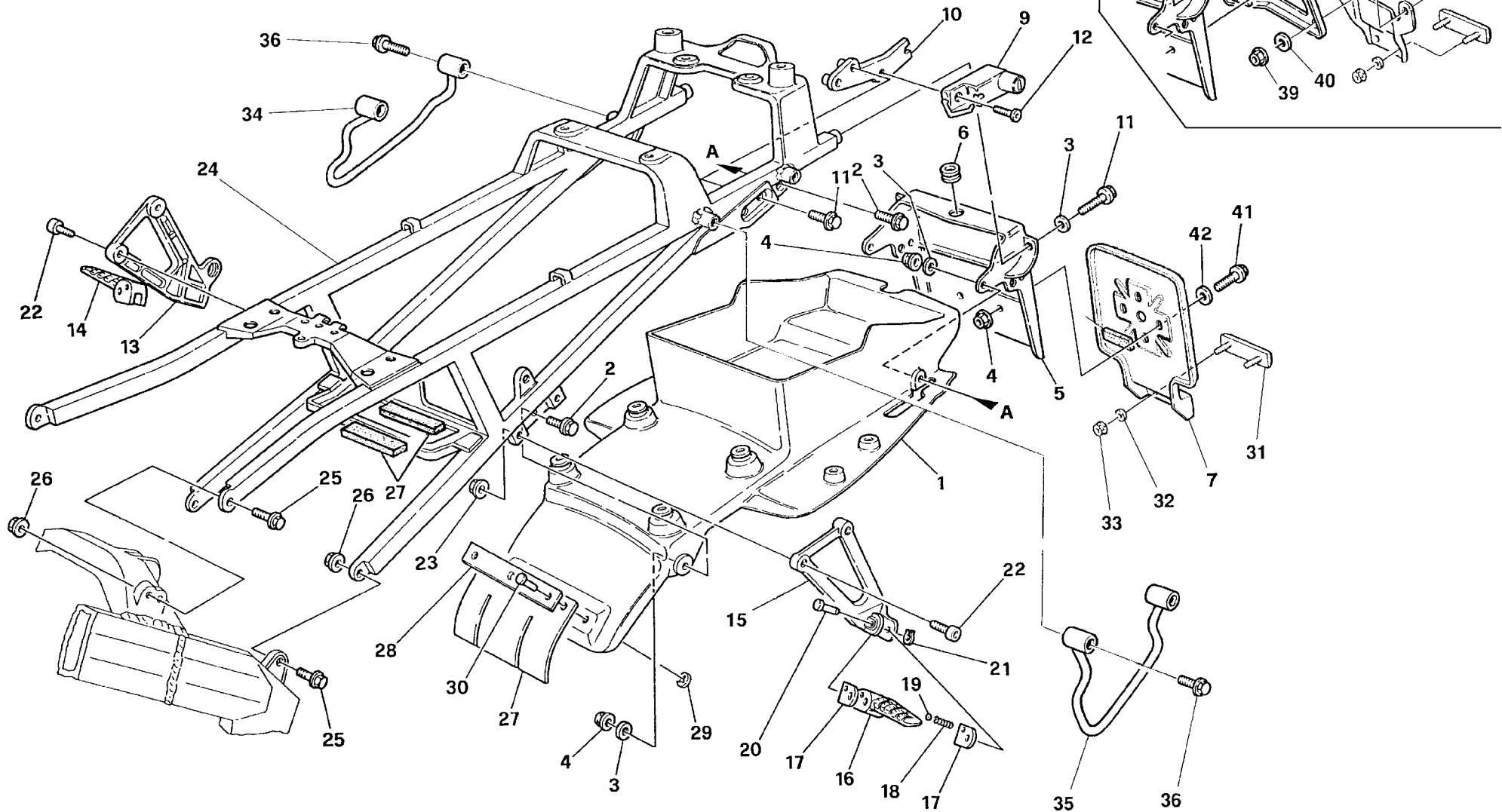

**TELAIO POSTERIORE - REAR FRAME SIDE  
CHASSIS ARRIERE - SATTELBRUCKE  
CUADRO POSTERIOR**

Note Notes Marke Notas	Pos. No. Index Pos.	N. Cod. Code No. Nr. Code Code Nr N. Cod.	Q.tà Q.ty Q.te M.ge C.ad	DENOMINAZIONE	NAME	DESIGNATION	BESHREIBUNG	DENOMINACION	Validità Validity Validité Gültig Valides
	1	8000 77809	1	Parafango posteriore	Rear mudguard	Garde boue arriere	Hint.Kotfluegel	Guarda barro trasero	
	2	8000 62727	4	Vite	Screw	Vis	Schraube	Tornillo	
	3	8000 04898	4	Rondella piana	Washer	Rondelle	Unterlegscheibe	Arandela plana	
	4	8000 44240	6	Dado autobloccante	Nut	Ecrou	Mutter	Tuerca	
	5	8000 77891	1	Portatarga	Plate holder	Porte balai	Schildtraeger	Porta matrícula	
	6	8000 07051	1	Tampone	Pad	Tampon	Stopfen	Tampón	
E	7	8000 62700	1	Piastra	Plate	Plaque	Platte	Placa	
	7	8000 94595	1	Piastra	Plate	Plaque	Platte	Placa	
E	8	8000 66308	2	Antivibrante	Silent block	Antivibration	Schwingungsdämpfer	Anti vibrador	
	9	8000 66155	1	Serratura casco	Helmet lock	Serrure casque	Helmschloss	Cerradura casco	
	10	8000 77771	1	Piastrina	Plate	Plaquette	Plättchen	Placa	
	11	8000 62725	2	Vite	Screw	Vis	Schraube	Tornillo	
	12	8000 58140	1	Vite	Screw	Vis	Schraube	Tornillo	
	13	80A0 70180	1	Supporto dx	R.H. holder	Support D.	Halter, R.	Soporte der.	
	14	8AA0 62562	1	Pedana destra	R. foot rest	Repose pied D.	Fussraste R.	Pedal derech.	
	15	80A0 70179	1	Supporto sx	L.H. holder	Support G.	Halter, L.	Soporte izq.	
	16	8AA0 62563	1	Pedana	Foot rest	Repose pieds	Fussbrett	Reposapieds	
	17	8000 A0070	4	Piastrina	Plate	Plaquette	Plättchen	Placa	
	18	8000 A0204	2	Molla	Spring	Ressort	Feder	Resorte	
	19	6BN0 21507	2	Sfera	Ball	Bille	Kugel	Esfera	
	20	80A0 53546	1	Perno	Pin	Pivot	Bolzen	Perno	
	21	66N1 21308	1	Anello seeger	Seeger ring	Bague seeger	Seegerring	Anillo Seeger	
	22	8E00 90426	4	Vite	Screw	Vis	Schraube	Tornillo	
	23	8000 43928	4	Dado autobloccante	Nut	Ecrou	Mutter	Tuerca	
	24	8000 77754	1	Telaio posteriore	Rear frame side	Chassis arrière	Sattelbrücke	Cuadro posterior	
	25	8C00 69056	4	Vite	Screw	Vis	Schraube	Tornillo	
	26	8000 43928	4	Dado autobloccante	Nut	Ecrou	Mutter	Tuerca	
	27	8000 66312	1	Protezione	Guard	Protection	Schutz	Protección	
	28	8000 66313	1	Piastrina	Plate	Plaquette	Plättchen	Placa	
	29	8D00 33690	3	Molla	Spring	Ressort	Feder	Resorte	
	30	8000 66298	3	Rivetto	Rivet	Rivet	Niet	Remache	
	31	8000 73834	1	Catadiottro	Reflector	Catadioptrique	Ruckstrahler	Catafaros	
	32	62N1 15765	2	Rondella elastica	Washer	Rondelle	Unterlegscheibe	Arandela plana	

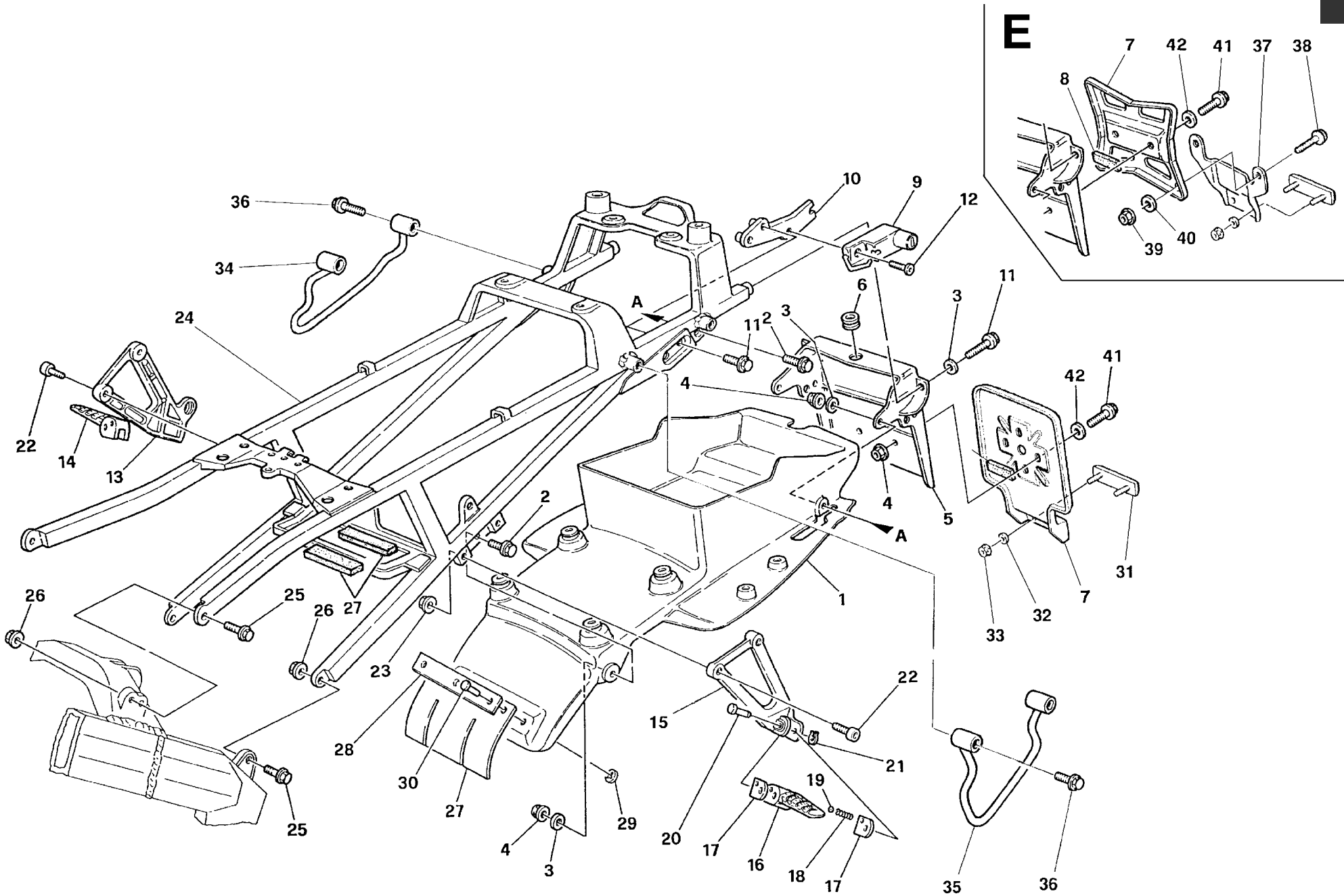

**TELAIO POSTERIORE - REAR FRAME SIDE  
CHASSIS ARRIERE - SATTELBRUCKE  
CUADRO POSTERIOR**

Note Notes Marke Notas	Pos. No. Index Pos.	N. Cod. Code No. Nr. Code Code Nr N. Cod.	Q.tà Q.ty Q.te M.ge C.ad	DENOMINAZIONE	NAME	DESIGNATION	BESHREIBUNG	DENOMINACION	Validità Validity Validité Gültig Valides
	33	61N1 15031	2	Dado autobloccante	Nut	Ecrou	Mutter	Tuerca	
	34	8000 92388	1	Maniglia Dx	R.H. handle	Poignée D.	Handgriff Rechte	Manilla derecha	
	35	8000 92387	1	Maniglia Sx	L.H. handle	Poignée G.	Handgriff Linke	Manilla izquierda	
	36	60N1 02509	4	Vite	Screw	Vis	Schraube	Tornillo	
E	37	8000 87696	1	Piastra	Plate	Plaque	Platte	Placa	
E	38	8C00 66525	2	Vite	Screw	Vis	Schraube	Tornillo	
E	39	8000 40718	2	Dado	Nut	Ecrou	Mutter	Tuerca	
E	40	61N1 15503	2	Rosetta	Washer	Rondelle	Unterlegscheibe	Arandela plana	
	41	60N1 01081	2	Vite	Screw	Vis	Schraube	Tornillo	
E	41	8000 62727	2	Vite	Screw	Vis	Schraube	Tornillo	
	42	8000 22271	4	Rondella piana	Washer	Rondelle	Unterlegscheibe	Arandela plana	
E	42	8000 04898	4	Rondella piana	Washer	Rondelle	Unterlegscheibe	Arandela plana	
E				Ad esaurimento	To fell out	A' finir	Ershöpfung	A' agotamiento	

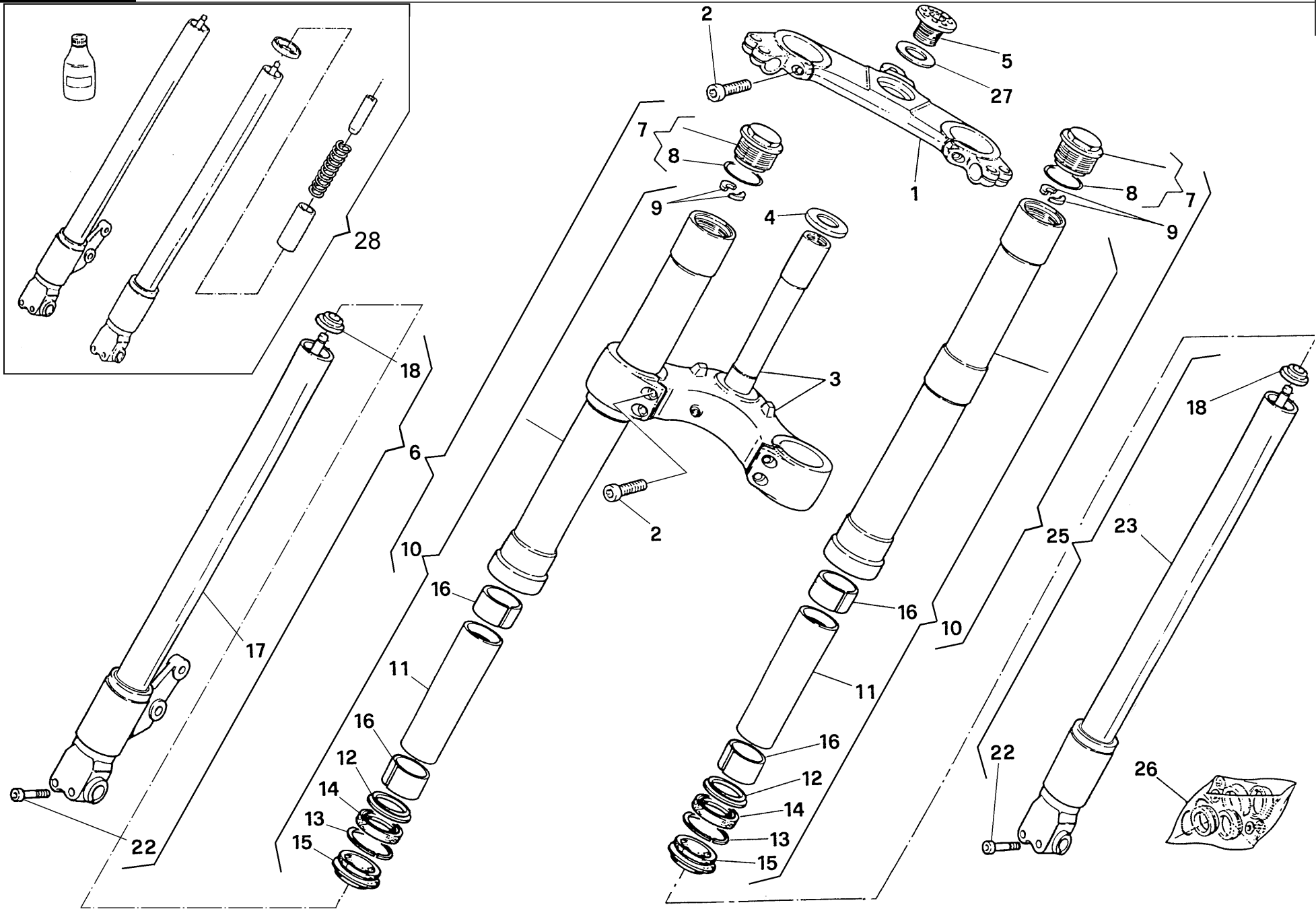



**SOSPENSIONE ANTERIORE - FRONT FORK ASSEMBLY  
 SUSPENSION AVANT - VORDERTELESKOPGABEL  
 SUSPENSION DELANTERA**

Note Notes Marken Notas	Pos. No. Index Pos.	N. Cod. Code No. Nr. Code Code Nr N. Cod.	Q.tà Q.ty Q.te M.ge C.ad	DENOMINAZIONE	NAME	DESIGNATION	BESHREIBUNG	DENOMINACION	Validità Validity Validité Gültig Valides
	1	8000 70140	1	Testa di sterzo	Steering head	Tête direction	Lenkkopf	Cabezal de dirección	
	2	8G00 90426	6	Vite	Screw	Vis	Schraube	Tornillo	
	3	8000 77792	1	Base sterzo- perno	Steering crown	Socle de direction	Gabelbrücke	Base de dirección	
	4	8000 70182	1	Calotta	Cover	Couvercle	Haube	Casquete	
	5	8000 70181	1	Vite	Screw	Vis	Schraube	Tornillo	
	6	8000 A0940	1	Stelo Dx. compl.	R.H. fork leg assy	Fourche complete D.	Telegabel Kpl. R.	Horquilla derech. compl.	
	7	8000 79889	2	Tappo compl.	Plug	Bouchon	Stopfen	Tapón	
H	8	8000 77360	2	Anello OR	O-Ring	Bague OR	O-Ring	Anillo OR	
	9	8000 79007	4	Semirondella	Split washer	Demi-rondelle	Halbscheibe	Semiarandela	
	10	8000 A0937	2	Portastelo compl.	Comp. stem holder	Porte-tige compl.	Kpl. Schafthalter	Portavastago	
	11	8000 79894	2	Tubetto	Pipe	Tuyau	Rohr	Tubo	
	12	8000 77378	2	Scodellino	Cup	Cuvette	Teller	Cubeta	
	13	8000 55520	2	Anello elastico	Seal ring	Bague d'étanchéité	Dichtungsring	Anillo elástico	
H	14	8000 37977	2	Anello di tenuta	Seal ring	Bague d'étanchéité	Dichtungsring	Anillo de retención	
H	15	8000 87038	2	Raschiapolvere	Dust scraper	Racloir poudre	Pulverabschaber	Rascador de polvo	
	16	8000 70966	4	Boccola	Bush	Douille	Buchse	Casquillo	
	17	8000 A0807	1	Tubo portante compl. Dx	R Pumping element	Element de pompage D	Pumpenelement R	Bombeadora compl. D	
	18	8000 79006	2	Anello portamolla	Ring	Bague	Ring	Anillo	
	22	8A00 69056	4	Vite	Screw	Vis	Schraube	Tornillo	
	23	8000 79891	1	Tubo portante compl. SX	L Pumping element	Element de pompage G	Pumpenelement L	Bombeadora compl. I	
	25	8000 A0941	1	Stelo Sx. com.	Compl. L.H. leg	Jambe G. compl.	Kpl. L. Bein	Pata izq. compl.	
	26	8000 79008	1	Gruppo guarnizioni	Gasket set	Grupe garniture	Dichtungssatz	Grupo juntas	
	27	8000 15397	1	Rosetta piana	Washer	Rondelle	Scheibe	Arandela	
KZ	28	8000 78890	1	Kit trasformazione S.P.	S.P. transformation kit	Set transformation S.P.	Kit S.P.	Kit S.P.	
H				Per i ricambi sono forniti anche in gruppo pos. 26	Gasket are also supplied in Bag Ref. N° 26	Pièces de rechange sont fournies en unités pos. 26	Die Dichtungen sind auch im Umschlag Bez. Nr 26	Partes de recambio es provisto en grupo pos. 26	
K				A richiesta per kit S.P. '99 cod. 800092789	Upon request for S.P. kit '99 code 800092789	Sur demande pour set S.P. '99 code 800092789	Auf Anfrage für Kit S.P. '99 Code 800092789	Bajo pedido por kit S.P. '99 cod. 800092789	
Z				A richiesta per kit S.P. '01 cod. 800097946	Upon request for S.P. kit '01 code 800097946	Sur demande pour set S.P. '01 code 800092789	Auf Anfrage für Kit S.P. '01 Code 800097946	Bajo pedido por kit S.P. '01 cod. 800097946	

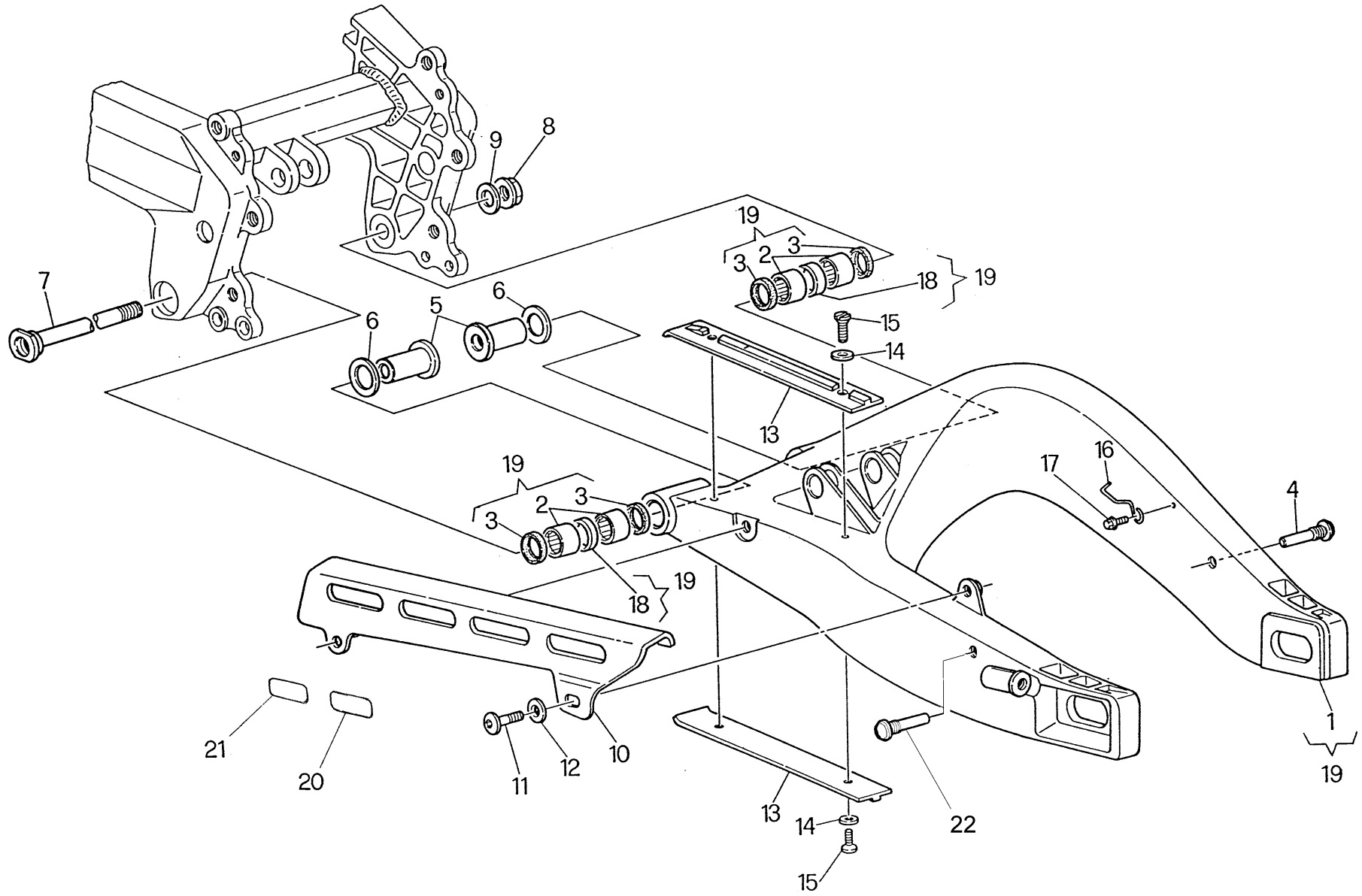

**FORCELLONE - FORK  
FOURCHE - GABEL  
HORQUILLA**

Note Notes Marke Notas	Pos. No. Index Pos.	N. Cod. Code No. Nr. Code Code Nr N. Cod.	Q.tà Q.ty Q.te M.ge C.ad	DENOMINAZIONE	NAME	DESIGNATION	BESHREIBUNG	DENOMINACION	Validità Validity Validité Gültig Valides
	1	80C0 62650	1	Forcellone	Fork	Fourche	Gabel	Horquilla	
	2	8000 32064	4	Cuscinetto a rullini	Needle bearing	Roulement à aiguilles	Nadelkäfig	Cojinete	
	3	8000 32065	4	Anello di tenuta	Seal ring	Bague d'étanchéité	Dichtungsring	Anillo de retención	
	4	8000 62669	1	Perno piastra portapinza	Pin	Pivot	Bolzen	Perno	
	5	8000 66188	2	Bussola	Bushing	Douille	Büchse	Manguito	
	6	8B00 32069	2	Rosetta Sp. 0,5	Washer	Rondelle	Scheibe	Arandela	
	6	8C00 32069	2	Rosetta Sp. 0,7	Washer	Rondelle	Scheibe	Arandela	
	6	8D00 32069	2	Rosetta Sp. 0,8	Washer	Rondelle	Scheibe	Arandela	
	6	8E00 32069	2	Rosetta Sp. 1	Washer	Rondelle	Scheibe	Arandela	
	6	8F00 32069	2	Rosetta Sp. 1,2	Washer	Rondelle	Scheibe	Arandela	
	7	8000 62637	1	Perno	Pin	Pivot	Bolzen	Perno	
	8	8000 62638	1	Dado	Nut	Ecrou	Mutter	Tuerca	
	9	8000 62639	1	Rondella piana	Washer	Rondelle	Unterlegscheibe	Arandela plana	
	10	8000 62654	1	Paracatena	Chain guard	Carter	Kettenkasten	Paracadena	
	10	8000 88306	1	Paracatena ( AUS )	Chain guard ( AUS )	Carter ( AUS )	Kettenkasten ( AUS )	Paracadena ( AUS )	
Q	10	8000 88306	1	Paracatena ( INA - MAL - ZA )	Chain guard ( INA - MAL - ZA )	Carter ( INA - MAL - ZA )	Kettenkasten ( INA - MAL - ZA )	Paracadena ( INA - MAL - ZA )	
	11	80B0 55703	2	Vite	Screw	Vis	Schraube	Tornillo	
	12	8000 56391	2	Rosetta	Washer	Rondelle	Scheibe	Arandela	
	13	8000 62622	2	Pattino catena	Chain slider	Glissière	Gleitbahn	Plato cadena	
	14	8000 62653	4	Distanziale	Spacer	Entretoise	Distanzstück	Separador	
	15	8000 57006	4	Vite	Screw	Vis	Schraube	Tornillo	
	16	8000 62561	1	Gancio	Hook	Crochet	Haken	Gancho	
	17	8000 62725	1	Vite	Screw	Vis	Schraube	Tornillo	
	18	8000 67977	2	Distanziale	Spacer	Entretoise	Distanzstück	Separador	
	19	8000 77795	1	Ass. forcellone completo	Fork assy	Fourche compl.	Gabelgruppe Kpl.	Horquilla compl.	
	20	8A00 66293	1	Decal pressione pneumatici MICHELIN	Tyre pressure transfer MICHELIN	Décal pression pneupape MICHELIN	Reifendruckstreifen MICHELIN	Calcom. presión neumáticos MICHELIN	
	20	8000 66293	1	Decal press. pneum. PIRELLI-DUNLOP	Tyre pressure transfer PIRELLI-DUNLOP	Décal press. pneup. PIRELLI-DUNLOP	Reifendruckstreifen PIRELLI-DUNLOP	Calcom. presi. neum. PIRELLI-DUNLOP	
	21	8000 66292	1	Decal regolazione catena	Chain adjustment transfer	Décal réglage chaîne	Kettenregelungsstreifen	Calcomania regulación cadena	
KZ	22	8000 73088	2	Perno per cavalletto di servizio	Pin	Pivot	Bolzen	Perno	
KZ				A richiesta per kit S.P.	Upon request for S.P. kit	Sur demande pour set S.P.	Auf Anfrage für Kit S.P.	Bajo pedido por kit S.P.	
Q				Versione Piena Potenza	Full power version	Vérision plein poissance	Version Plus Potenz	Versión potencia plena	

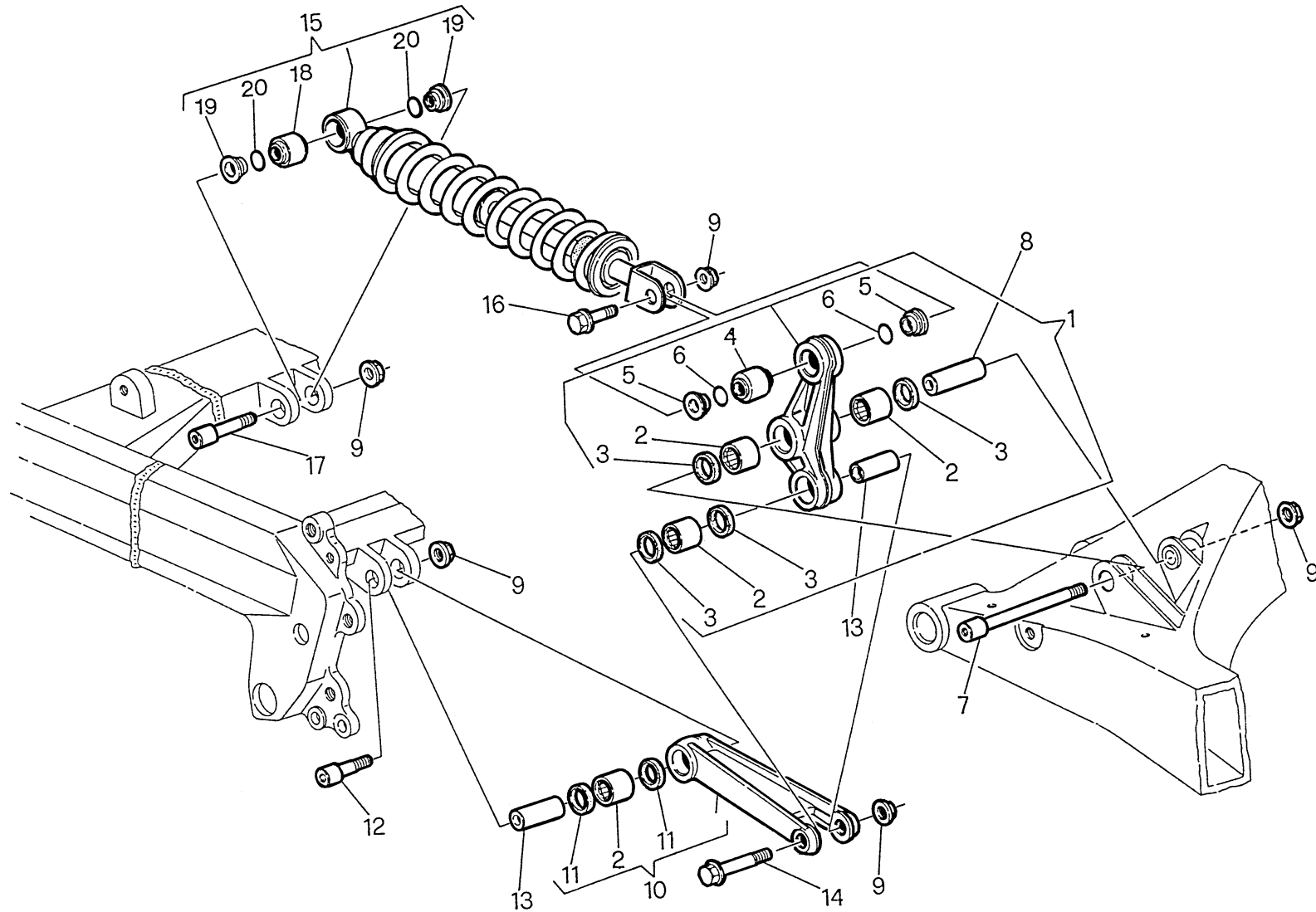

**SOSPENSIONE POSTERIORE - REAR SUSPENSION  
SUSPENSION ARRIERE - HINTERAUFHANGUNG  
SOUSPENSION TRASERA**

Note Notes Marke Notas	Pos. No. Index Pos.	N. Cod. Code No. Nr. Code Code Nr N. Cod.	Q.tà Q.ty Q.te M.ge C.ad	DENOMINAZIONE	NAME	DESIGNATION	BESHREIBUNG	DENOMINACION	Validità Validity Validité Gültig Valides
	1	8000 77030	1	Bilanciere completo	Rocking lever	Balancier	Schwinge	Balancines	
	2	8000 38956	4	Cuscinetto a rullini	Needle bearing	Roulement à aiguilles	Nadelkäfig	Cojinete	
	3	8000 38957	4	Anello di tenuta	Seal ring	Bague d'étanchéité	Dichtungsring	Anillo de retención	
	4	8000 72168	1	Cuscinetto sferico	Bearing	Roulement	Lager	Cojinete	
	5	8000 67165	2	Bussola	Bushing	Douille	Büchse	Manguito	
	6	8000 76785	2	Guarnizione	Gasket	Garnitue	Dichtung	Junta	
	7	8000 62571	1	Vite	Screw	Vis	Schraube	Tornillo	
	8	8000 62574	1	Distanziale	Spacer	Entretoise	Distanzstück	Separador	
	9	8000 42022	5	Dado autobloccante	Nut	Ecrou	Mutter	Tuerca	
	10	8000 66190	1	Biella completa	Connecting rod compl.	Bielle compl.	Pleuelstange kpl.	Biela motor completa	
	11	8000 38957	2	Anello di tenuta	Seal ring	Bague d'étanchéité	Dichtungsring	Anillo de retención	
	12	8000 62570	1	Vite	Screw	Vis	Schraube	Tornillo	
	13	8000 62575	2	Distanziale	Spacer	Entretoise	Distanzstück	Separador	
	14	8000 62572	1	Vite	Screw	Vis	Schraube	Tornillo	
	15	8000 A0632	1	Ammortizzatore completo	Shock absorber assy	Ammortisseur compl.	Stossdampfer kpl.	Amortigüador compl.	
	16	8000 62573	1	Vite	Screw	Vis	Schraube	Tornillo	
	17	8000 62569	1	Vite	Screw	Vis	Schraube	Tornillo	
	18	8000 72168	1	Cuscinetto sferico	Bearing	Roulement	Lager	Cojinete	
	19	8000 72169	2	Bussola	Bushing	Douille	Büchse	Manguito	
	20	8000 34323	2	Guarnizione	Gasket	Garnitue	Dichtung	Junta	

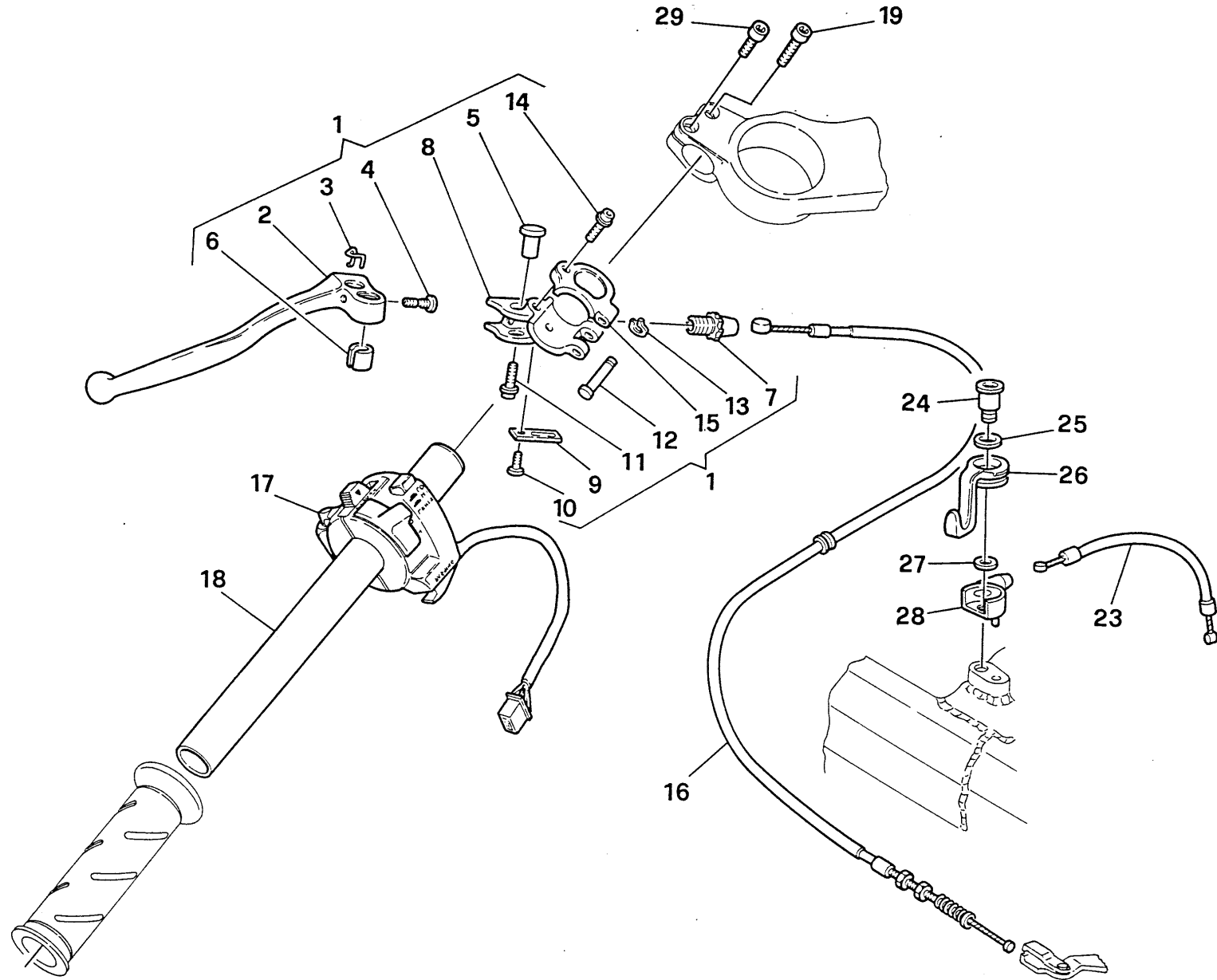

**COMANDI LATO SX. - LEFT CONTROLS  
 COMMANDES GAUCHE - LINKSSEITIGE BEDIENTEILE  
 MANDO LADO IZQUIERDO**

Note Notes Marken Notas	Pos. No. Index Pos.	N. Cod. Code No. Nr. Code Code Nr N. Cod.	Q.tà Q.ty Q.te M.ge C.ad	DENOMINAZIONE	NAME	DESIGNATION	BESHREIBUNG	DENOMINACION	Validità Validity Validité Gültig Valides
	1	8000 77776	1	Assieme comando frizione	Clutch control and light	Ensemble embrayage	Kupplungseinschaltungs	Juego mando embrague	
	2	8000 77940	1	Leva frizione	Lever	Levier	Hebel	Palanca	
	3	8000 71488	1	Molla	Spring	Ressort	Feder	Resorte	
	4	8000 77944	1	Registro	Adjustment	Réglage	Regler	Regulación	
	5	8000 77946	1	Perno	Pin	Pivot	Bolzen	Perno	
	6	8000 77941	1	Bussola	Bushing	Douille	Buchse	Manguito	
	7	8000 77945	1	Registro	Adjustment	Réglage	Regler	Regulación	
	8	8000 77939	1	Supporto	Support	Support	Halterung	Soporte	
	9	8000 71487	1	Molla	Spring	Ressort	Feder	Resorte	
	10	8A00 35408	2	Vite	Screw	Vis	Schraube	Tornillo	
	11	8D00 90425	2	Vite	Screw	Vis	Schraube	Tornillo	
	12	8000 77943	1	Perno	Pin	Pivot	Bolzen	Perno	
	13	66N1 21303	1	Anello elastico	Split ring	Bague d'arret	Haltering	Anillo de retenciion	
	14	8G00 90425	2	Vite	Screw	Vis	Schraube	Tornillo	
	15	8000 77942	1	Cavallotto	U bolt	Cavalier	Bügelbolzen	Caballate	
	16	8000 77777	1	Assieme trasmissione frizione	Clutch cable assy	Cable comm. embrayage comp.	Kupplungszung kpl	Juego trans. embrague	
	17	8000 77900	1	Commutatore sinistro completo	Commutator L.	Commutateur G.	Kommutator L.	Commutador izquierdo compl.	
	18	8000 77784	1	Semimanubrio sinistro	Left semihandlebar	Semiguïdon gauche	Linke Lenkerhälfte	Semimanillar izquierdo	
	19	8J00 90425	1	Vite	Screw	Vis	Schraube	Tornillo	
	23	8000 70186	1	Trasm. starter	Starter wire	Trasm. starter	Anlassen kabel	Trasm. starter	
	24	8000 77791	2	Vite	Screw	Vis	Schraube	Tornillo	
	25	8000 71489	1	Rosetta elastica	Washer	Rondelle	Scheibe	Arandela	
	26	8000 77790	1	Leva starter	Lever	Levier	Hebel	Palanca	
	27	8A00 70163	1	Rosetta sp. 0,4	Washer	Rondelle	Scheibe	Arandela	
	27	8B00 70163	1	Rosetta sp. 0,5	Washer	Rondelle	Scheibe	Arandela	
	27	8C00 70163	1	Rosetta sp. 0,6	Washer	Rondelle	Scheibe	Arandela	
	27	8000 70163	1	Rosetta sp. 0,7	Washer	Rondelle	Scheibe	Arandela	
	27	8D00 70163	1	Rosetta sp. 0,8	Washer	Rondelle	Scheibe	Arandela	
	28	8000 77789	1	Comando starter	Starter	Starter	Startersteuerung	Mando starter	
	29	8G00 90425	1	Vite	Screw	Vis	Schraube	Tornillo	

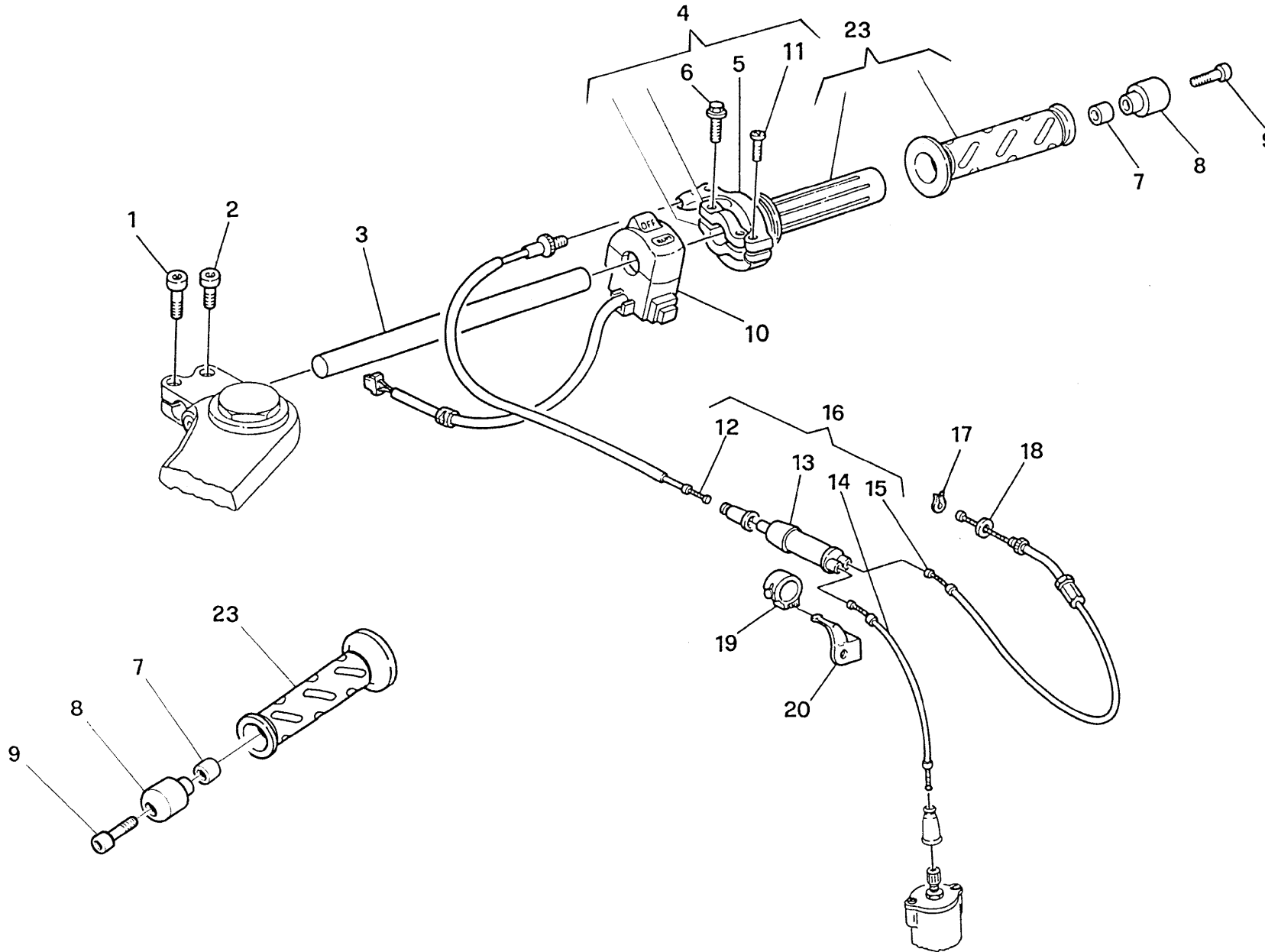



Note Notes Notas	Pos. No. Index Pos.	N. Cod. Code No. Nr. Code Code Nr N. Cod.	Q.tà Q.ty Q.te M.ge C.ad	DENOMINAZIONE	NAME	DESIGNATION	BESHREIBUNG	DENOMINACION	Validità Validity Validité Gültig Valides
	1	8J00 90425	2	Vite	Screw	Vis	Schraube	Tornillo	
	2	8G00 90425	2	Vite	Screw	Vis	Schraube	Tornillo	
	3	8000 77787	1	Semimanubrio destro	Right semihandlebear	Semiguïdon droit	Rechte Lenkerhälfte	Semimanillar derecho	
	4	8000 77788	1	Assieme comando gas	Control throttle	Complète comm. gaz	Gassteuerung klp.	Mando acelerador compl.	
	5	6584 0021A	1	Coperchio	Cover	Couvercle	Deckel	Tapa	
	6	8000 62728	2	Vite	Screw	Vis	Schraube	Tornillo	
	7	8000 66163	2	Dado elastico	Nut	Ecrou	Mutter	Tuerca	
	8	8000 66164	2	Contrappeso	Counterweight	Contrepoids	Lenkergegengewicht	Contrapeso	
	9	60N1 02518	2	Vite	Screw	Vis	Schraube	Tornillo	
	10	8000 77901	1	Commutatore destro	R. commutator	Commutateur D.	Kommutor R.	Commutador D.	
	11	8000 66774	2	Vite	Screw	Vis	Schraube	Tornillo	
	12	8000 77947	1	Trasmis. comando gas e pompa	Throttle wire	Fil comm.gaz	Gaszugkabel	Transmisión	
	13	8000 21198	1	Astuccio sdoppiatore	Caables cage	Etui fils	Kabeltasche	Estuche	
	14	8000 77950	1	Trasmissione comando carburatore	Throttle wire	Fil comm. gaz	Gaszugkabel	Trasmisión mando carbura=dòr	
	15	8000 77949	1	Trasmis. comando pompa olio	Throttle wire	Fil comm. gaz	Gaszugkabel	Transmis. mando bomba aceite	
	16	8000 70185	1	Assieme trasmissione comando gas	Throttle cable assy	Cable commande gaz. complete	Gaszugkabel kpl	Juego transmisión mando gas	
	17	66N1 21309	1	Anello elastico	Split ring	Anneau ressort	Drahtspengring	Anillo elastico	
	18	8000 09721	1	Rosetta	Washer	Rondelle	Scheibe	Arandela	
	19	8000 74287	1	Fascetta	Clamp	Collier	Schelle	Banda	
	20	8000 78182	1	Supporto	Support	Support	Halterung	Soporte	
	23	6562 0121A	1	Tubo com. gas con manopola	Gas pipe with grip	Tuyau gaz avec poignée	Gasrohr mit griff	Tubo gas con manopola	

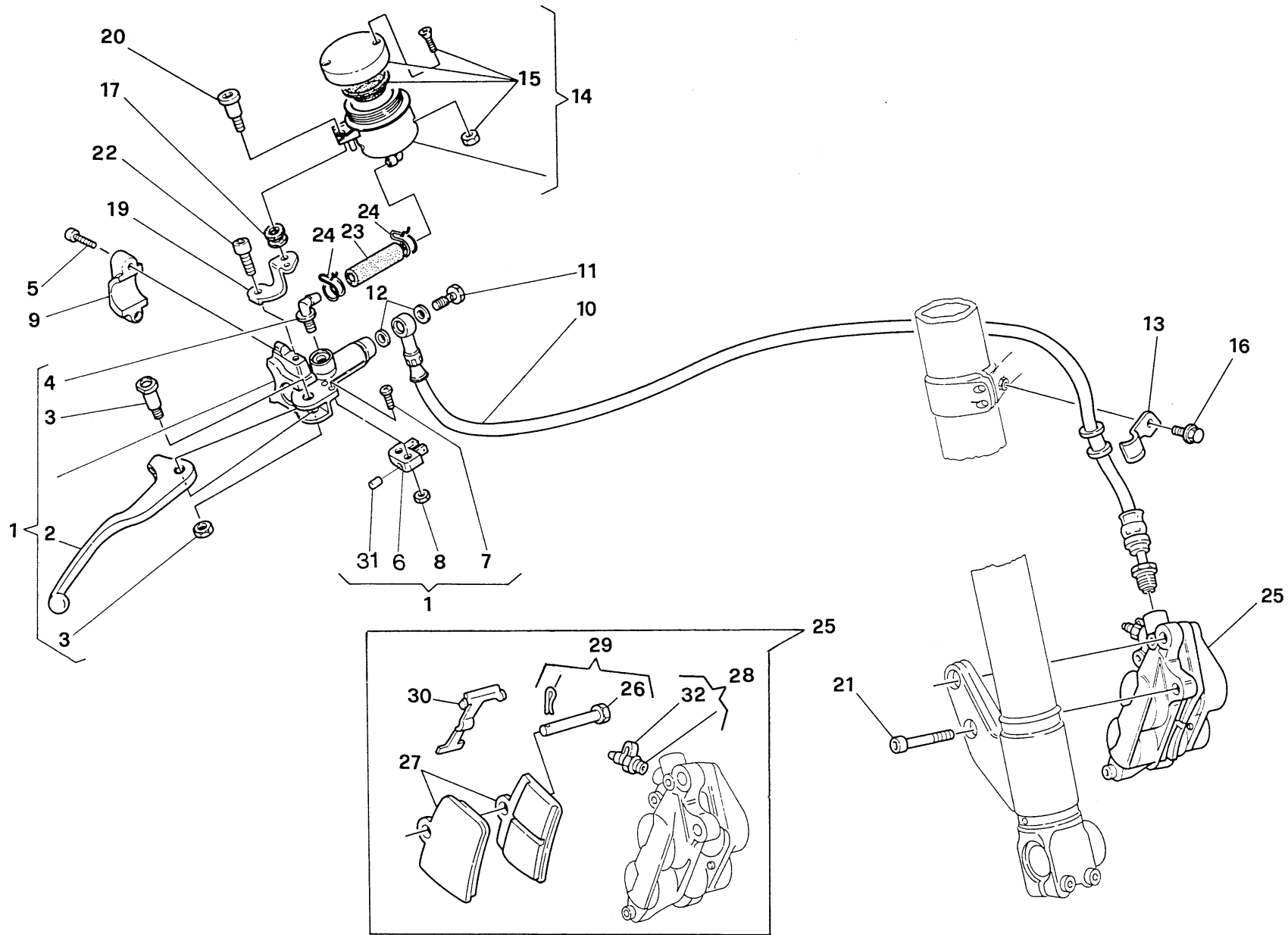

**FRENO ANTERIORE - FRONT BRAKE  
FREIN AVANT - VORDERRADBREMSE  
FRENO DELANTERO**

Note Notes Marke Notas	Pos. No. Index Pos.	N. Cod. Code No. Nr. Code Code Nr N. Cod.	Q.tà Q.ty Q.te M.ge C.ad	DENOMINAZIONE	NAME	DESIGNATION	BESHREIBUNG	DENOMINACION	Validità Validity Validité Gültig Valides
	1	8000 77962	1	Assieme pompa	Pump assy	Pompe compl.	Bremspumpe	Bomba compl.	
	2	8000 52662	1	Leva	Lever	Levier	Hebel	Palanca	
	3	8000 46664	1	Gruppo revisione perno leva	Lever pin set	Kit revision pivot levier	Hebelbolzensatz	Grupo revis. perno palanca	
	4	8000 42345	1	Gruppo revisione raccordo	Connection set	Kit de revision raccord	Anschluss repar. .Satz	Grupo revis. empalme	
	5	8G00 90425	2	Vite	Screw	Vis	Schraube	Tornillo	
	6	8000 47953	1	Interruttore stop	Stop switch	Interrupteur stop	Stopschalter	Interruptor stop	
	7	60N1 07701	2	Vite	Screw	Vis	Schraube	Tornillo	
	8	61N1 15001	2	Dado	Nut	Ecrou	Mutter	Tuerca	
	9	8000 67161	1	Cavallotto	U bolt	Cavalier	Bügelbolzen	Caballete	
	10	8000 72234	1	Tubo mandata	Pipe	Tuyau	Rohr	Tubo	
	11	8000 57155	1	Vite	Screw	Vis	Schraube	Tornillo	
	12	8000 21480	2	Rosetta	Washer	Rondelle	Scheibe	Arandela	
	13	8000 70173	1	Piastrina	Plate	Plaquette	Plättchen	Placa	
	14	8000 66181	1	Serbatoio olio	Oil tank	Reservoir huile	Öltank	Depósito aceite	
	15	8000 68490	1	Gruppo Tappo	Cork unit	Groupe bouchon	Stopfeinheit	Grupo tapón	
	16	8000 62725	1	Vite	Screw	Vis	Schraube	Tornillo	
	17	0370 72020	1	Antivibrante	Silent block	Antivibration	Schwingungsdämpfer	Anti vibrador	
	19	8292 0841A	1	Piastrina	Plate	Plaquette	Plättchen	Placa	
	20	7791 0921A	1	Vite	Screw	Vis	Schraube	Tornillo	
	21	8000 A1007	2	Vite fiss. pinza	Screw	Vis	Schraube	Tornillo	
	22	8000 62725	1	Vite	Screw	Vis	Schraube	Tornillo	
	23	8G00 66179	1	Tubo	Pipe	Tuyau	Rohr	Tubo	
	24	7411 0151A	2	Fascetta	Clamp	Collier	Schelle	Banda	
	25	8000 77781	1	Pinza completa di pastiglie	Caliper	Etrier	Sattel	Pinza	
	26	8000 77783	1	Perno ritegno pastiglie	Pin	Pivot	Bolzen	Perno	
	27	8000 78331	1	Coppia pastiglie	Pads pair	Paire plaquettes	Bremsbelagpaar	Pareja pastillas	
	28	8000 60404	1	Gruppo revisione spurgo	Bleeding set	Kit de rev. curage	Reinigungsatz	Grupo revis. purga	
	29	8000 80301	1	Ass. gruppo rev. perno	Plug overhaul device assy	Ensemble groupe revision axe	Übersicht bolzenrevisionsgruppe	Conjunto grupo revision perno	
	30	8000 77782	1	Molla	Spring	Ressort	Feder	Resorte	
	31	8000 57772	1	Nottolino	Pawl	Cliquet	Klinke	Pestillo	
	32	8000 53259	1	Parapolvere	Dust cover	Pare poudre	Schutzhaube	Parapolvo	

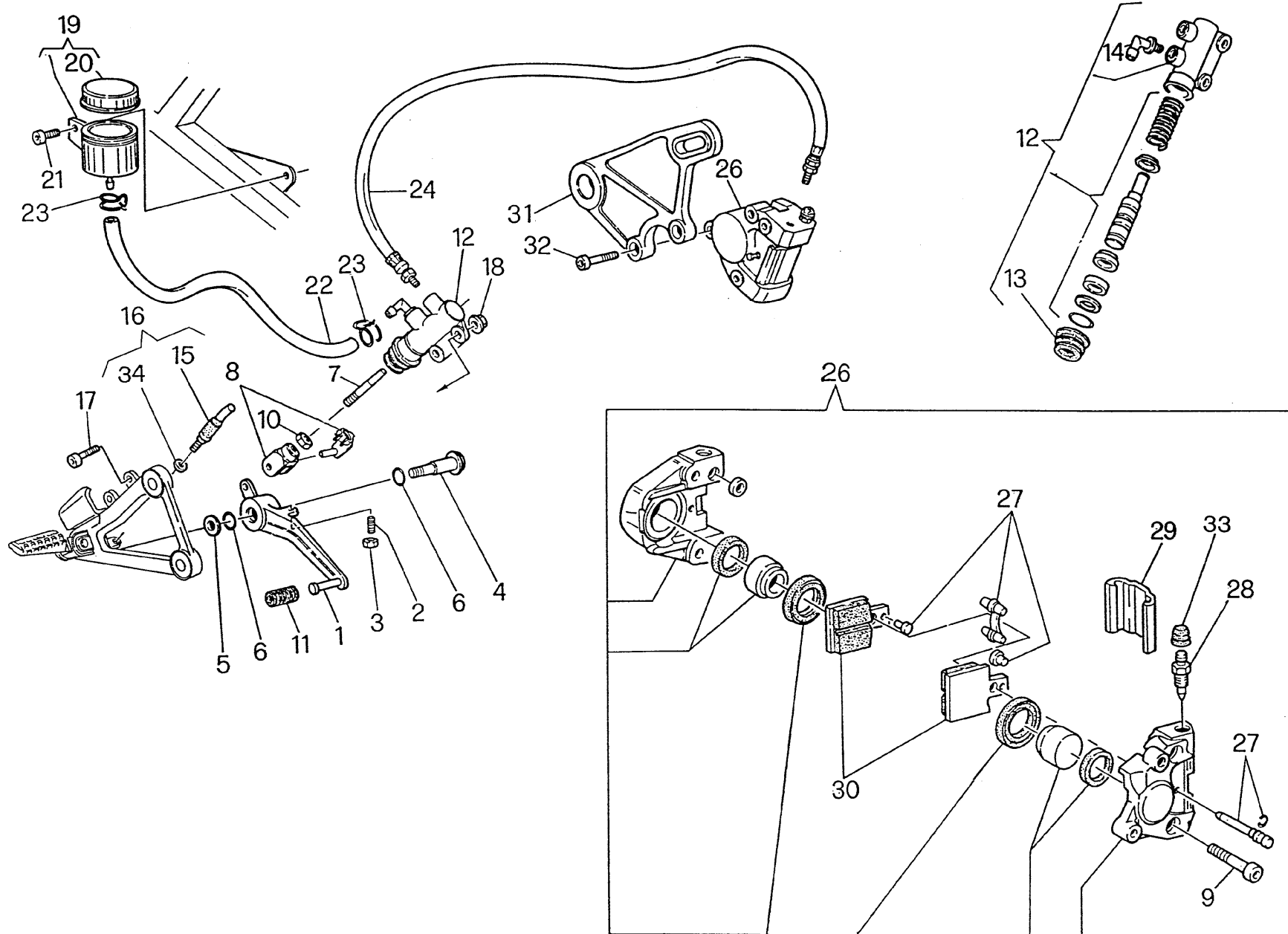

**FRENO POSTERIORE - REAR BRAKE  
FREIN ARRIERE - EINSTELLUNG  
FRENO TRASERO**

Note Notes Marke Notas	Pos. No. N. Index Pos.	N. Cod. Code No. Nr. Code Code Nr N. Cod.	Q.tà Q.ty Q.te M.ge C.ad	DENOMINAZIONE	NAME	DESIGNATION	BESHREIBUNG	DENOMINACION	Validità Validity Validité Gültig Valides
	1	8000 66177	1	Pedale freno	Pedal	Pedale	Pedal	Pedal	
	2	8000 67981	1	Grano	Dowel	Grain	Stift	Pasador	
	3	61N1 15062	1	Dado	Nut	Ecrou	Mutter	Tuerca	
	4	80A0 53548	1	Perno	Pin	Pivot	Bolzen	Perno	
	5	8000 59485	1	Rondella	Washer	Rondelle	Scheibe	Arandela	
	6	8000 01199	2	Anello	Ring	Bague	Ring	Anillo	
	7	8000 62586	1	Asta rinvio	Transmission rod	Barre de renvoi	Vorgelegestab	Varilla transmisión	
	8	80A0 55757	1	Forcella	Fork	Fourche	Gabel	Horquilla	
	9	60N1 07351	2	Vite	Screw	Vis	Schraube	Tornillo	
	10	61N1 15062	1	Dado	Nut	Ecrou	Mutter	Tuerca	
	11	8000 62636	1	Manicotto	Sleeve	Manchon	Muffe	Manguito	
	12	8000 55991	1	Assieme pompa freno	Brake pump assy	Pompe frein	Bremspumpe	Bomba freno	
	13	8000 57758	1	Cuffia parapolvere	Dust cover	Pare poussière	Staubdeckel	Tapa retención polvo	
	14	8000 57757	1	Gruppo revisore raccordo	Connection set	Kit revision raccord	Anschluss repar. Satz	Grupo revis. empalme	
	15	5394 0031B	1	Interruttore stop	Stop switch	Interrupteur stop	Stopschalter	Interruptor stop	
	16	8000 98016	1	Kit interruttore stop	Stop switch kit	Set interrupteur stop	Stopschalter Kit	Kit interruptor stop	
	17	8G00 90425	2	Vite	Screw	Vis	Schraube	Tornillo	
	18	8000 44240	2	Dado autobloccante	Nut	Ecrou	Mutter	Tuerca	
	19	8000 66529	1	Serbatoio	Tank assy	Réservoir	Tank	Depósito	
	20	8000 66305	1	Tappo	Plug	Bouchon	Verschluss	Tapón	
	21	8000 62725	1	Vite	Screw	Vis	Schraube	Tornillo	
	22	8A00 66179	1	Tubo	Pipe	Tuyau	Rohr	Tubo	
	23	7411 0151A	2	Fascetta	Clamp	Collier	Schelle	Banda	
	24	8000 66180	1	Tubo	Pipe	Tuyau	Rohr	Tubo	
	26	8000 66304	1	Ass. pinza completa di pastiglie	Caliper assy	Pince de frein, compl.	Bremszange, Kpl.	Pinza compl.	
	27	8000 66503	1	Gruppo revisione perni	Lever pin set	Kit revision pivot levier	Hebelbolzensatz	Grupo revis. perno palanca	
	28	8000 39727	1	Gruppo revisione spurgo	Bleeding set	Kit de rev. curage	Reinigungsatz	Grupo revis. purga	
	29	8000 39726	1	Coperchietto	Cover	Couvercle	Deckel	Tapa	
	30	8000 46147	1	Coppia pastiglie	Pads pair	Paire plaquettes	Bremsbelagpaar	Pareja pastillas	
	31	80A0 60697	1	Piastra porta pinza	Plate	Plaque	Platte	Placa	
	32	60N1 07351	2	Vite	Screw	Vis	Schraube	Tornillo	
	33	8000 48432	2	Parapolvere	Boot	Pare poussière	Staubdeckel	Parapolvos	
	34	62N1 15506	1	Rosetta	Washer	Douille	Scheibe	Arandela	

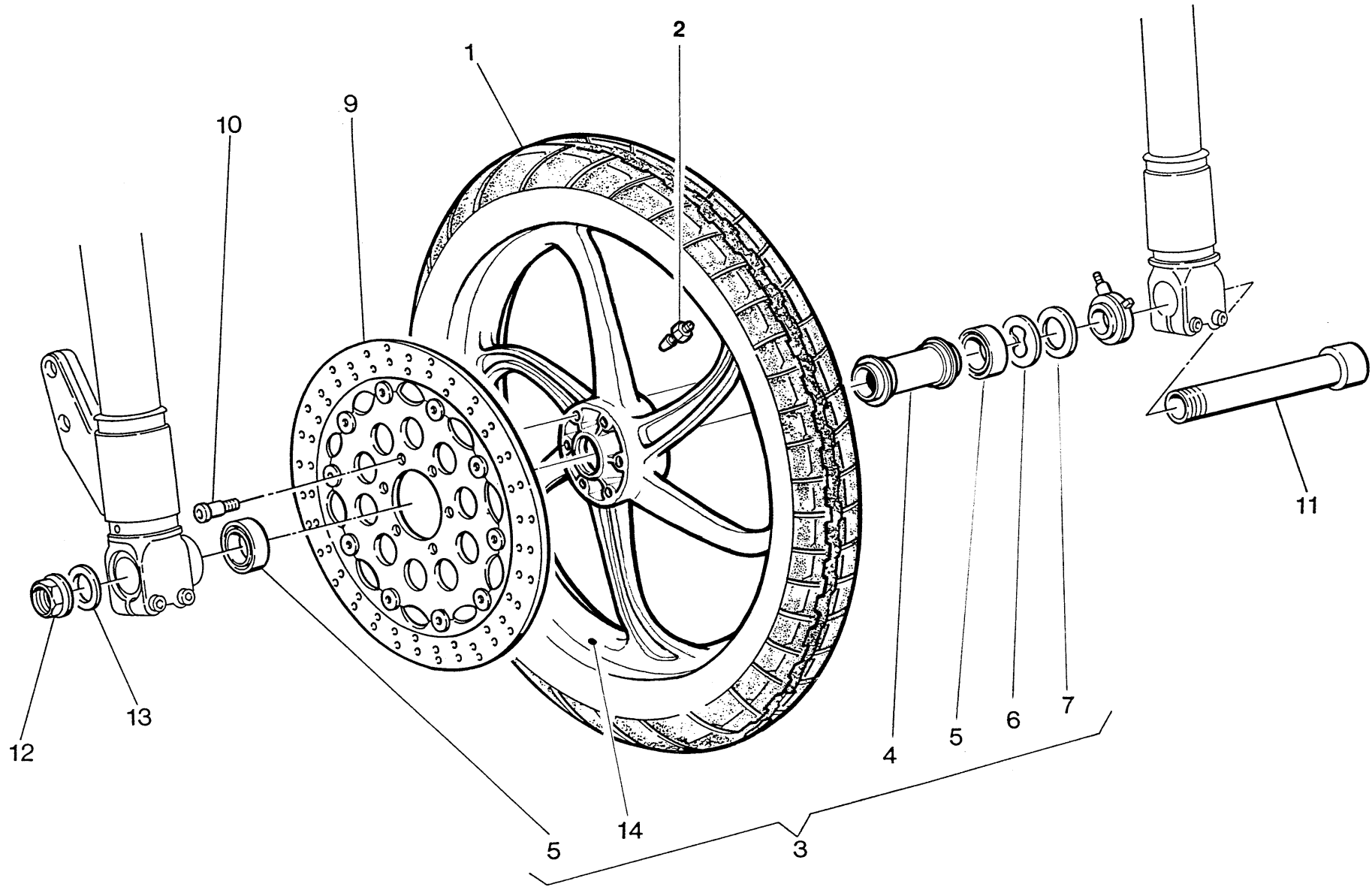

Note Notes Marken Notas	Pos. No. Index Pos.	N. Cod. Code No. Nr. Code Code Nr N. Cod.	Q.tà Q.ty Q.te M.ge C.ad	DENOMINAZIONE	NAME	DESIGNATION	BESHREIBUNG	DENOMINACION	Validità Validity Validité Gültig Valides
I	1	8000 87741	1	Pneumatico 110/70 R 17" TX 15	Tyre	Pneu	Reifen	Neumático	
	2	8000 91796	1	Valvola	Valve	Soupape	Ventil	Válvula	
	3	8000 90835	1	Cerchio ruota completo	Wheel rim assy	Jante roue com.	Radfelge kpl.	Llanta rueda com.	
	4	8000 85907	1	Distanziale interno	Spacer	Entretoise	Distanzstück	Separador	
	5	8000 72228	2	Cuscinetto	Bearing	Roulement	Kugellager	Cojinete	
	6	8000 62648	1	Trascinatore rinvio	Driving entrainer	Entraîneur	Mitnehmer	Arrastrador	
	7	8000 64471	1	Anello di tenuta	Seal ring	Bague d'étanchéité	Dichtungsring	Anillo de retención	
	9	8000 62587	1	Disco freno	Brake disc	Disque frein	Bremsscheibe	Disco freno	
	10	8000 41460	6	Vite	Screw	Vis	Schraube	Tornillo	
	11	8000 70167	1	Perno	Pin	Pivot	Bolzen	Perno	
	12	8000 70115	1	Dado	Nut	Ecrou	Mutter	Tuerca	
	13	8000 70119	1	Rosetta	Washer	Rondelle	Scheibe	Arandela	
I	14		1	Cerchio (codice colore GRIMECA ALFA-MIC.145.0.5623)	Rim (colour code GRIMECA ALFA-mic.145.0.5623)	Jante roue (cod.coleur GRIMECA ALFA-mic.145.0.5623)	Radfelge (Code Farbe GRIMECA ALFA-mic.145.0.5623)	Llanta rueda (código color GRIMECA ALFA-mic.145.0.5623)	
H				In alternativa	In alternative	En alternative	Die Auswahl	En alternativa	
I				Non fornito	Not supplied	Ne pas fornit	Nich versorgt	Sin forniture	

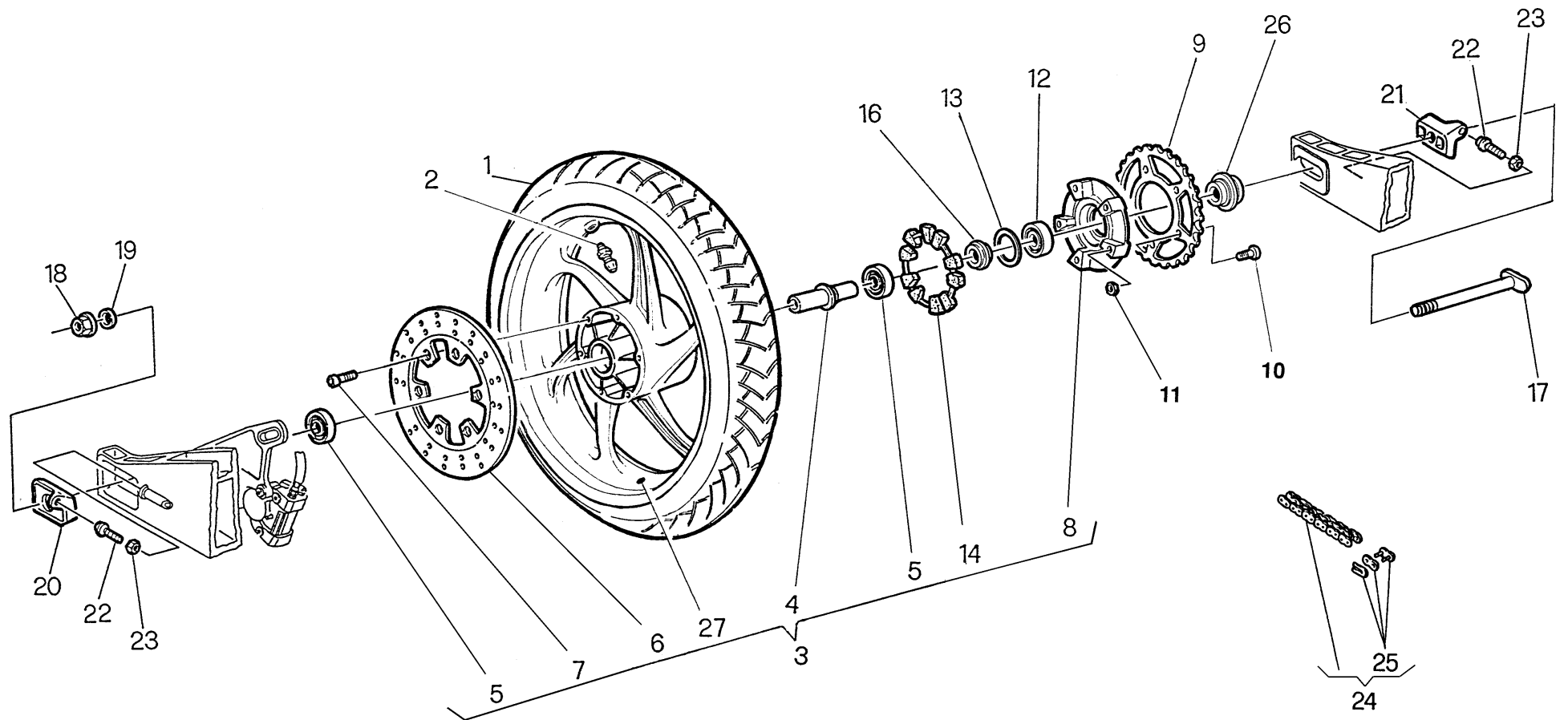



**RUOTA POSTERIORE - REAR WHEEL  
ROUE ARRIERE - HINTERRAD  
RUEDA TRASERA**

Note Notes Marken Notas	Pos. No. Index Pos.	N. Cod. Code No. Nr. Code N. Cod.	Q.tà Q.ty Q.te M.ge C.ad	DENOMINAZIONE	NAME	DESIGNATION	BESHREIBUNG	DENOMINACION	Validità Validity Validité Gültig Valides
I	1	8000 87742	1	Pneum. 150/60 ZR 17" TX 25	Tyre	Pneu	Reifen	Neumático	
	2	8000 91796	1	Valvola	Valve	Soupape	Ventil	Válvula	
	3	8D00 91794	1	Cerchio ruota com.	Wheel rim assy	Jante roue com.	Radfelge kpl.	Llanta rueda com.	
	3	8000 91794	1	Cerchio ruota com. ( D )	Wheel rim assy ( D )	Jante roue com. ( D )	Radfelge kpl. ( D )	Llanta rueda com. ( D )	
Q	3	8A00 91794	1	Cerchio ruota com. (BR - AUS - INA - MAL - ZA)	Wheel rim assy (BR - AUS - INA - MAL - ZA)	Jante roue com. (BR - AUS - INA - MAL - ZA)	Radfelge kpl. (BR - AUS - INA - MAL - ZA)	Llanta rueda com. (BR - AUS - INA - MAL - ZA)	
	4	8A00 62606	1	Distanziale interno	Spacer	Entretoise	Distanzstück	Separador	
	5	8000 15659	2	Cuscinetto	Bearing	Roulement	Lager	Cojinete	
	6	8000 62615	1	Disco freno	Brake disc	Disque frein	Bremsscheibe	Disco freno	
	7	8000 53185	6	Vite fissaggio disco	Screw	Vis	Schraube	Tornillo	
	8	80B0 78016	1	Supporto (codice colore GRIMECA ALFA-MIC.145.0.5623)	Support (colour code GRIMECA ALFA-mic.145.0.5623)	Support (cod.coleur GRIMECA ALFA-mic.145.0.5623)	Halterung (Code Farbe GRIMECA ALFA-mic.145.0.5623)	Soporte (código color GRIMECA ALFA-mic.145.0.5623)	
	9	8F00 62609	1	Corona Z = 38	Ring gear	Couronne	Kranz	Corona	
	9	8C00 62609	1	Corona Z = 43 ( D )	Ring gear Z = 43 ( D )	Couronne Z = 43 ( D )	Kranz Z = 43 ( D )	Corona Z = 43 ( D )	
KZ	9	8A00 73093	1	Corona Z = 48	Ring gear	Couronne	Kranz	Corona	
KZ	9	8B00 73093	1	Corona Z = 49	Ring gear	Couronne	Kranz	Corona	
KZ	9	8C00 73093	1	Corona Z = 50	Ring gear	Couronne	Kranz	Corona	
P	9	8000 62609	1	Corona Z = 41	Ring gear	Couronne	Kranz	Corona	
Q	9	8000 62609	1	Corona Z = 41 (BR - AUS - INA - MAL - ZA)	Ring gear (BR - AUS - INA - MAL - ZA)	Couronne (BR - AUS - INA - MAL - ZA)	Kranz (BR - AUS - INA - MAL - ZA)	Corona (BR - AUS - INA - MAL - ZA)	
	10	8000 62732	5	Vite	Screw	Vis	Schraube	Tornillo	
	11	8000 56410	5	Dado autobloccante	Nut	Ecrou	Mutter	Tuerca	
	12	8A00 43567	1	Cuscinetto	Bearing	Roulement	Lager	Cojinete	
	13	66N0 21275	1	Anello elastico	Split ring	Anneau ressort	Drahtspengring	Anillo elastico	
	14	8000 62608	1	Parastrappi	Flexible coupling	Pièce caoutchouc	Gummidämpfer	Para tirones	
	16	8000 87573	1	Boccola riduz. cuscinetto	Bush	Douille	Buchse	Manguito	
	17	8000 62612	1	Perno	Pin	Pivot	Bolzen	Perno	
	18	8000 62613	1	Dado	Nut	Ecrou	Mutter	Tuerca	
	19	80A0 19963	1	Rosetta piana	Washer	Rondelle	Scheibe	Arandela	
	20	80A0 60689	1	Tendicatena destra	Chain adjuster	Tendeur de chaine	Kettenspanner	Tensor de cadena	
	21	80A0 60690	1	Tendicatena sinistra	Chain adjuster	Tendeur de chaine	Kettenspanner	Tensor de cadena	
	22	8000 62576	2	Vite	Screw	Vis	Schraube	Tornillo	
	23	80A0 67502	1	Dado	Nut	Ecrou	Mutter	Tuerca	

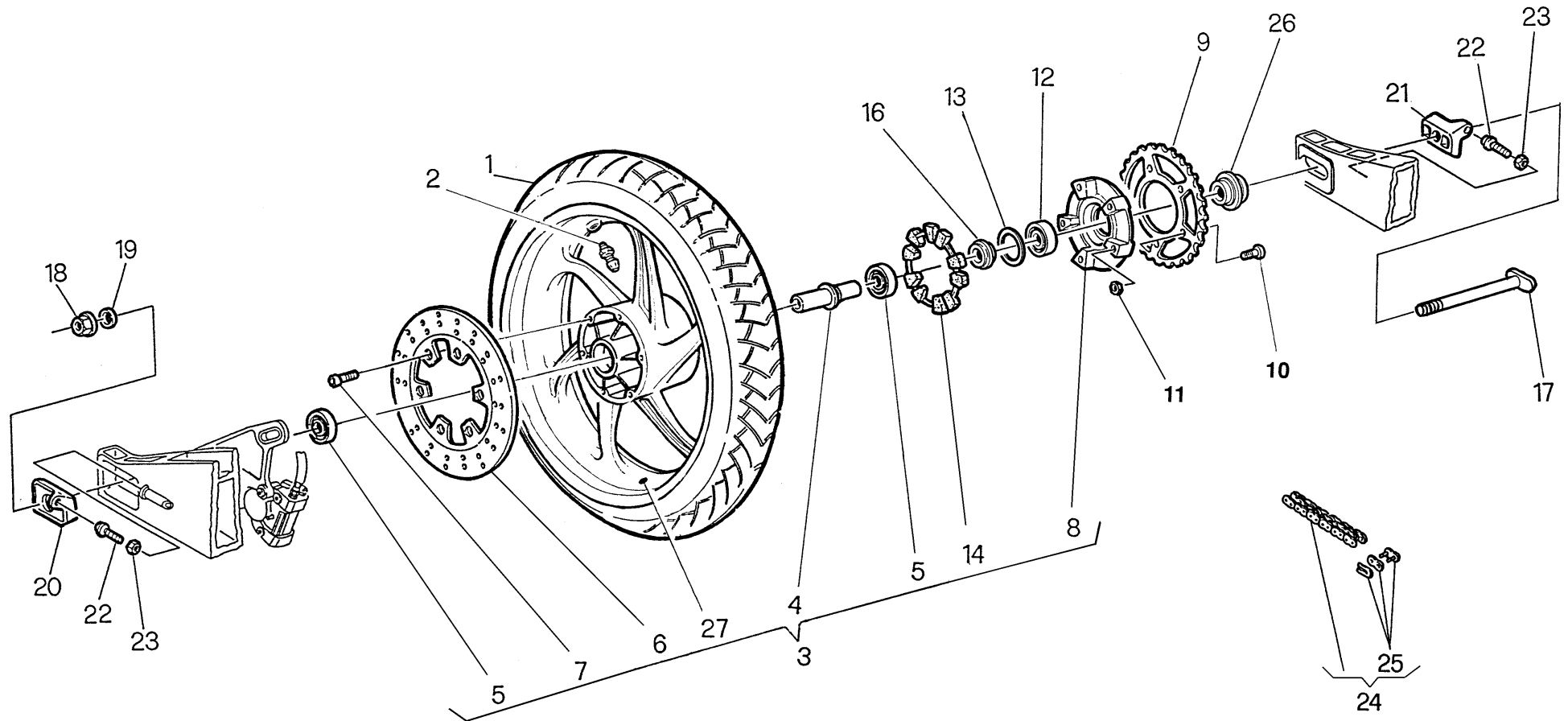

**RUOTA POSTERIORE - REAR WHEEL  
ROUE ARRIERE - HINTERRAD  
RUEDA TRASERA**

Note Notes Marke Notas	Pos. No. Index Pos.	N. Cod. Code No. Nr. Code Code Nr N. Cod.	Q.tà Q.ty Q.te M.ge C.ad	DENOMINAZIONE	NAME	DESIGNATION	BESHREIBUNG	DENOMINACION	Validità Validity Validité Gültig Valides
H	24	8D00 60831	1	Catena regina	Chain	Chaîne	Kette	Cadena	
H	24	8B00 79938	1	Catena takasago	Chain	Chaîne	Kette	Cadena	
	24	8E00 60831	1	Catena regina ( D )	Chain ( D )	Chaîne ( D )	Kette ( D )	Cadena ( D )	
KZ	24	8000 68017	1	Catena	Chain	Chaîne	Kette	Cadena	
P	24	8C00 60831	1	Catena	Chain	Chaîne	Kette	Cadena	
Q	24	8C00 60831	1	Catena	Chain	Chaîne	Kette	Cadena	
				<b>(BR - AUS - INA - MAL - ZA)</b>	<b>(BR - AUS - INA - MAL - ZA)</b>	<b>(BR - AUS - INA - MAL - ZA)</b>	<b>(BR - AUS - INA - MAL - ZA)</b>	<b>(BR - AUS - INA - MAL - ZA)</b>	
	25	8000 47456	1	Giunto regina	Coupling	Joint	Kupplung	Junta	
	25	8000 79939	1	Giunto takasago	Coupling	Joint	Kupplung	Junta	
KZ	25	8000 24078	1	Giunto	Coupling	Joint	Kupplung	Junta	
P	25	8000 47456	1	Giunto	Coupling	Joint	Kupplung	Junta	
	26	8000 87578	1	Distanziale esterno	Outside spacer	Entretoise ext.	Distanzstück	Separador	
I	27		1	Cerchio (codice colore GRIMECA ALFA-MIC.145.0.5623)	Rim (colour code GRIMECA ALFA-mic.145.0.5623)	Jante roue (cod.coleur GRIMECA ALFA-mic.145.0.5623)	Radfelge (Code Farbe GRIMECA ALFA-mic.145.0.5623)	Llanta rueda (código color GRIMECA ALFA-mic.145.0.5623)	
H				In alternativa	In alternative	En alternative	Die Auswahl	En alternativa	
I				Non fornito	Not supplied	Ne pas fournit	Nich versorgt	Sin forniture	
K				A richiesta per kit S.P. '99 cod. 800092789	Upon request for S.P. kit '99 code 800092789	Sur demande pour set S.P. '99 code 800092789	Auf Anfrage für Kit S.P. '99 Code 800092789	Bajo pedido por kit S.P. '99 cod. 800092789	
Z				A richiesta per kit S.P. '01 cod. 800097946	Upon request for S.P. kit '01 code 800097946	Sur demande pour set S.P. '01 code 800092789	Auf Anfrage für Kit S.P. '01 Code 800097946	Bajo pedido por kit S.P. '01 cod. 800097946	
P				Kit potenziamento N. 800093893	Kit poweri No 800093893	Kit de puissance Nr 800093893	Kit Potenz Nr 800093893	Kit Potencia N. 800093893	
Q				Versione Piena Potenza	Full power version	Vérision plein puissance	Version Plus Potenz	Vérision potencia piena	

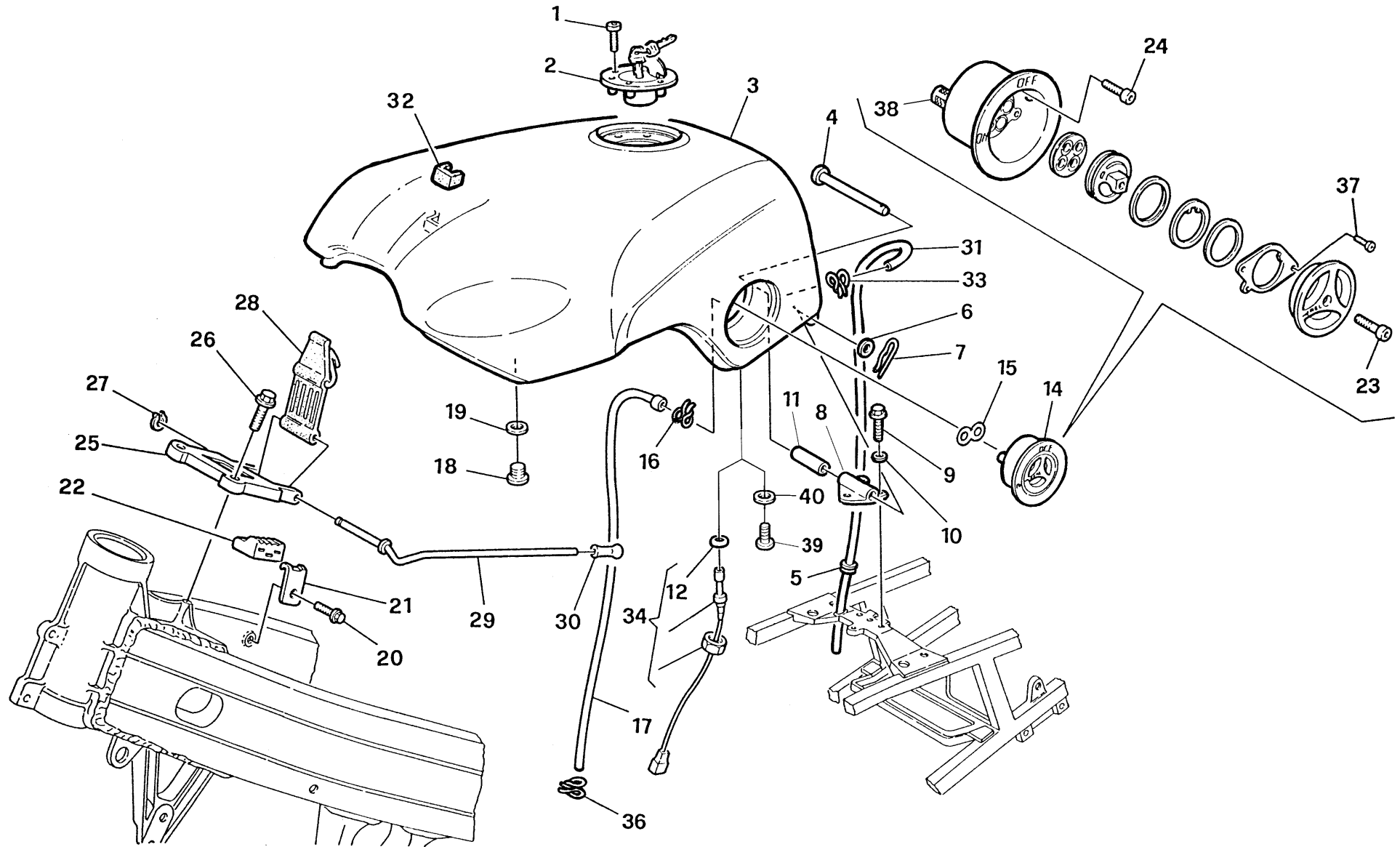

**SERBATOIO ALIMENTAZIONE - GAS TANK, FEED  
RESERVOIR, ALIMENTATION - KRAFTSTOFFBEHALTER, ZUFUEHRUNG  
DEPOSITO, ALIMENTACION**

Note Notes Marke Notas	Pos. No. Index Pos.	N. Cod. Code No. Nr. Code N. Cod.	Q.tà Q.ty Q.te M.ge C.ad	DENOMINAZIONE	NAME	DESIGNATION	BESHREIBUNG	DENOMINACION	Validità Validity Validité Gültig Valides
	1	60N1 07330	1	Vite	Screw	Vis	Schraube	Tornillo	
	2	8000 66157	1	Tappo	Plug	Bouchon	Verschluss	Tapón	
	3	8000 92325	1	Serbatoio (cod.colore B=8E43)	Tank assy (color cod. B=8E43)	Réservoir (cod.coleur B=8E43)	Tank (cod.Farbe B=8E43)	Depósito (cod.color B=8E43)	
	3	80A0 94047	1	Serbatoio (cod.colore E=8D83)	Tank assy (color cod. E=8D83)	Réservoir (cod.coleur E=8D83)	Tank (cod.Farbe E=8D83)	Depósito (cod.color E=8D83)	
	3	80B0 94047	1	Serbatoio (cod.colore F=8E38)	Tank assy (color cod. F=8E38)	Réservoir (cod.coleur F=8E38)	Tank (cod.Farbe F=8E38)	Depósito (cod.color F=8E38)	
	4	8000 66362	1	Perno	Pin	Pivot	Bolzen	Perno	
	5	8000 78201	1	Passacavo	Fairlead	Passe-cable	Kabelfurung	Prensa cable	
	6	8000 67953	2	Rosetta piana	Washer	Rondelle	Scheibe	Arandela	
	7	8000 62705	1	Spinetta	Pin	Goupille	Stift	Clavija	
	8	80A0 62672	1	Staffa	Bracket	Etrier	Buegel	Brida	
	9	8000 62725	3	Vite	Screw	Vis	Schraube	Tornillo	
	10	8000 04898	3	Rosetta	Washer	Rondelle	Scheibe	Arandela	
	11	8000 66363	1	Bussola	Bushing	Douille	Büchse	Manguito	
	12	8000 77907	1	Guarnizione	Gasket	Garnitue	Dichtung	Junta	
	14	8000 70165	1	Rubinetto	Cock assy	Robinet compl.	Kraftstoffahn, Kpl.	Llave de paso compl.	
	15	8000 70160	1	Guarnizione	Gasket	Garnitue	Dichtung	Junta	
	16	8G00 67963	1	Fascetta	Clamp	Collier	Schelle	Banda	
	17	8000 77755	1	Condotto	Duct	Conduit	Rohr	Conducto	
	18	8000 77921	1	Vite	Screw	Vis	Schraube	Tornillo	
	19	8000 21840	1	Rosetta	Washer	Rondelle	Scheibe	Arandela	
	20	8000 62726	2	Vite	Screw	Vis	Schraube	Tornillo	
	21	8000 78332	2	Piastrina	Plate	Plaquette	Plättchen	Placa	
	22	8000 77922	2	Tampone	Pad	Tampon	Stopfen	Tampón	
	23	8D00 90424	1	Vite	Screw	Vis	Schraube	Tornillo	
	24	8D00 90424	2	Vite	Screw	Vis	Schraube	Tornillo	
	25	80A0 70175	1	Supporto	Support	Support	Halterung	Soporte	
	26	8000 62727	2	Vite	Screw	Vis	Schraube	Tornillo	
	27	66N1 21307	1	Rondella elastica di ritegno	Washer	Rondelle	Scheibe	Arandela	
	28	8000 70178	1	Cinghietta	Belt	Courroie	Riemen	Correa	
	29	8000 77923	1	Astina	Control rod	Coulisseau	Steuerstange	Varilla	
	30	8000 62751	1	Terminale	Terminal	Terminal	Anschluss	Terminal	
	31	8000 78202	1	Tubo scarico benzina	Pipe	Tuyau	Rohr	Tubo	
	32	8000 77920	1	Protezione	Guard	Protection	Schutz	Protección	

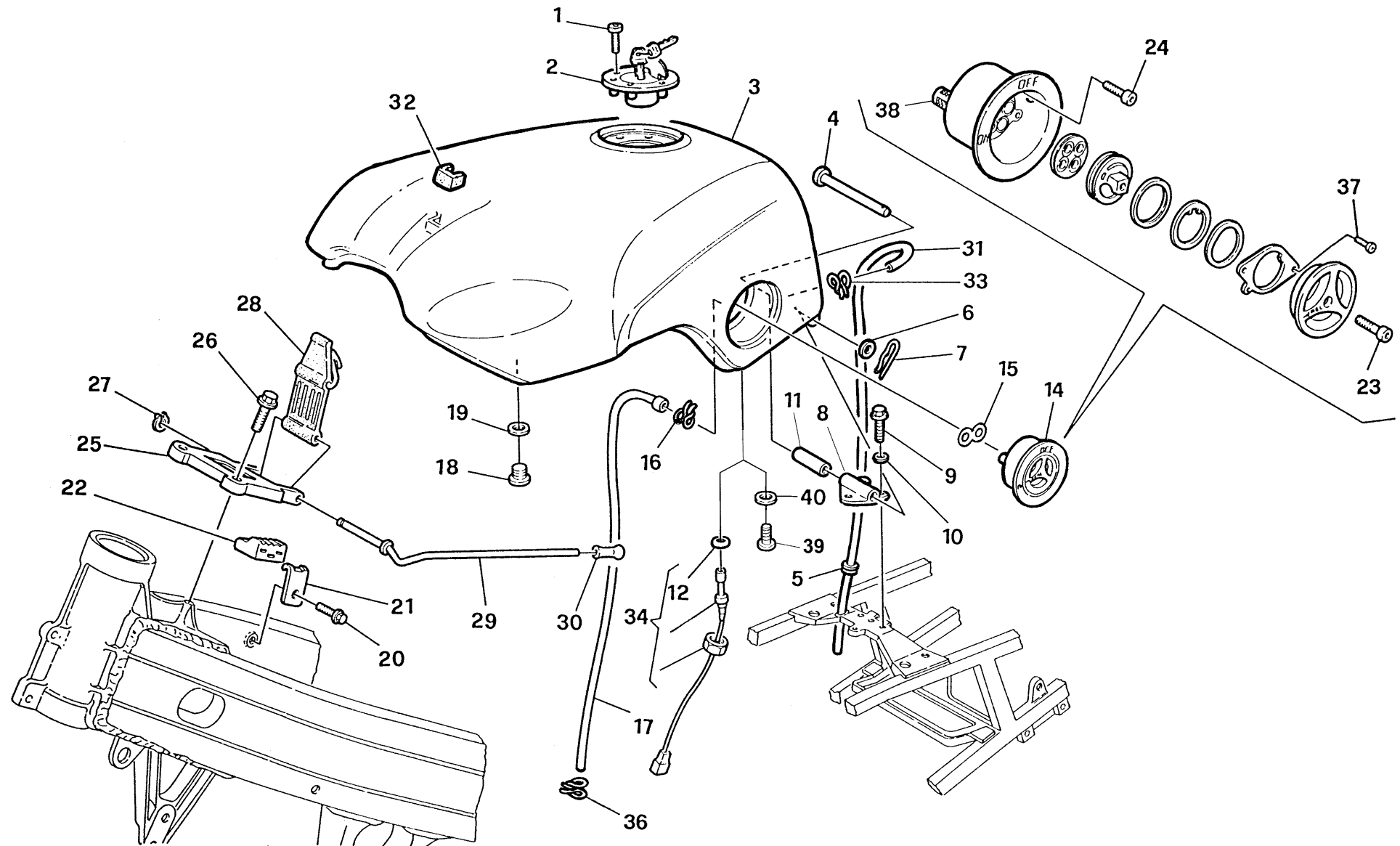

Note Notes Marke Notas	Pos. No. Index Pos.	N. Cod. Code No. Nr. Code Code Nr N. Cod.	Q.tà Q.ty Q.te M.ge C.ad	DENOMINAZIONE	NAME	DESIGNATION	BESHREIBUNG	DENOMINACION	Validità Validity Validité Gültig Valides
	33	8F00 67963	1	Fascetta	Clamp	Collier	Schelle	Banda	
	34	8000 77905	1	Sonda riserva completa	Fuel level feler compl.	Sonde niveau carb. ansamble	Fuhler Kpl.	Sonda riserva compl.	
	36	8000 67963	1	Fascetta	Clamp	Collier	Schelle	Banda	
	37	8000 48412	2	Vite fiss. piastrina	Screw	Vis	Schraube	Tornillo	
	38	8000 70158	1	Filtro benzina	Fuel filter	Filtre essence	Benzinfilter	Filtro gasolina	
KZ	39	8000 81941	1	Tappo chiusura foro sonda	Plug	Bouchon	Verschluss	Tapòn	
KZ	40	8000 78656	1	Rosetta	Washer	Rondelle	Scheibe	Arandela	
K				A richiesta per kit S.P. '99 cod. 800092789	Upon request for S.P. kit '99 code 800092789	Sur demande pour set S.P. '99 code 800092789	Auf Anfrage für Kit S.P. '99 Code 800092789	Bajo pedido por kit S.P. '99 cod. 800092789	
Z				A richiesta per kit S.P. '01 cod. 800097946	Upon request for S.P. kit '01 code 800097946	Sur demande pour set S.P. '01 code 800092789	Auf Anfrage für Kit S.P. '01 Code 800097946	Bajo pedido por kit S.P. '01 cod. 800097946	

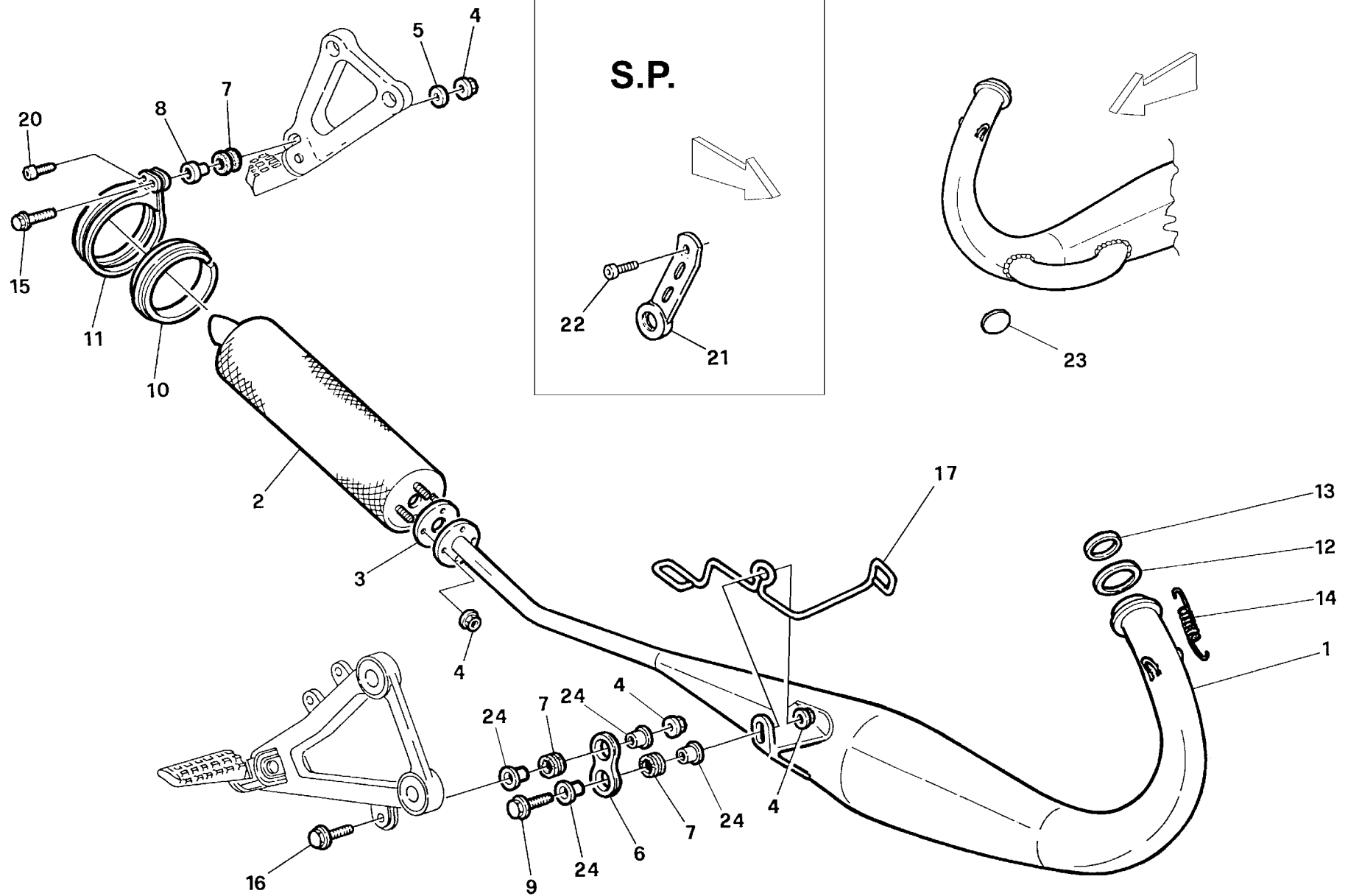



**SCARICO - EXHAUST SYSTEM  
TUYAU D'ÉCHAPPEMENT - AUSPUFFROHR  
TUBO DE ESCAPE**

Note Notes Marke Notas	Pos. No. Index Pos.	N. Cod. Code No. Nr. Code Code Nr N. Cod.	Q.tà Q.ty Q.te M.ge C.ad	DENOMINAZIONE	NAME	DESIGNATION	BESHREIBUNG	DENOMINACION	Validità Validity Validité Gültig Valides
	1	8000 99015	1	Tubo di scarico	Exhaust pipe	Tuyau d'échapp.	Auspuffrohr	Tubo de escape	
K	1	8000 85972	1	Tubo di scarico	Exhaust pipe	Tuyau d'échapp.	Auspuffrohr	Tubo de escape	
Z	1	8000 96883	1	Tubo di scarico	Exhaust pipe	Tuyau d'échapp.	Auspuffrohr	Tubo de escape	
Q	1	8000 A1045	1	Tubo di scarico	Exhaust pipe	Tuyau d'échapp.	Auspuffrohr	Tubo de escape	
				<b>(BR - AUS - INA - MAL - ZA)</b>	<b>(BR - AUS - INA - MAL - ZA)</b>	<b>(BR - AUS - INA - MAL - ZA)</b>	<b>(BR - AUS - INA - MAL - ZA)</b>	<b>(BR - AUS - INA - MAL - ZA)</b>	
	2	8000 99017	1	Silenziatore	Silencer	Silencieux	Schalldampfer	Silenciador	
KZ	2	8000 78335	1	Silenziatore	Silencer	Silencieux	Schalldampfer	Silenciador	
	3	8A00 67174	1	Guarnizione	Gasket	Garnitue	Dichtung	Junta	
	4	8000 44240	7	Dado	Nut	Ecrou	Mutter	Tuerca	
	5	8000 22271	1	Rosetta piana	Washer	Rondelle	Scheibe	Arandela	
	6	80A0 62649	1	Supporto	Support	Support	Halterung	Soporte	
	7	8000 62651	3	Silentblock	Silentblock	Silentblock	Silentblock	Silentblock	
	8	8000 62652	1	Distanziale	Spacer	Entretoise	Distanzstück	Separador	
	9	8000 62730	1	Vite	Screw	Vis	Schraube	Tornillo	
	10	8000 78184	1	Guarnizione	Gasket	Garnitue	Dichtung	Junta	
	11	8000 90502	1	Fascetta	Clamp	Collier	Schelle	Banda	
K	11	8000 77966	1	Fascetta D 75,5	Clamp D 75,5	Collier D 75,5	Schelle D 75,5	Banda D 75,5	
	12	8000 46487	1	Anello OR	O Ring	Bague OR	O Ring	Anillo OR	
KZ	12	8A00 23186	1	Anello OR	O Ring	Bague OR	O Ring	Anillo OR	
	13	8000 27073	1	Guarnizione	Gasket	Garnitue	Dichtung	Junta	
KZ	13	8B00 73541	1	Guarnizione	Gasket	Garnitue	Dichtung	Junta	
	14	8000 34924	2	Molla	Spring	Ressort	Feder	Resorte	
KZ	14	8000 62341	2	Molla	Spring	Ressort	Feder	Resorte	
	15	8000 62729	1	Vite	Screw	Vis	Schraube	Tornillo	
	16	8A00 67545	1	Vite	Screw	Vis	Schraube	Tornillo	
	17	8000 94671	1	Passacavo	Fairlead	Passecâble	Kabelführung	Prensacable	
	20	8C00 90424	1	Vite	Screw	Vis	Schraube	Tornillo	
KZ	21	8000 79040	1	Tirante	Tie rod	Tirant	Spannstange	Tirante	
K				A richiesta per kit S.P. '99 cod. 800092789	Upon request for S.P. kit '99 code 800092789	Sur demande pour set S.P. '99 code 800092789	Auf Anfrage für Kit S.P. '99 Code 800092789	Bajo pedido por kit S.P. '99 cod. 800092789	
Z				A richiesta per kit S.P. '01 cod. 800097946	Upon request for S.P. kit '01 code 800097946	Sur demande pour set S.P. '01 code 800092789	Auf Anfrage für Kit S.P. '01 Code 800097946	Bajo pedido por kit S.P. '01 cod. 800097946	
P				Kit potenziamento N. 800093893	Kit poweri No 800093893	Kit de puissance Nr 800093893	Kit Potenz Nr 800093893	Kit Potencia N. 800093893	

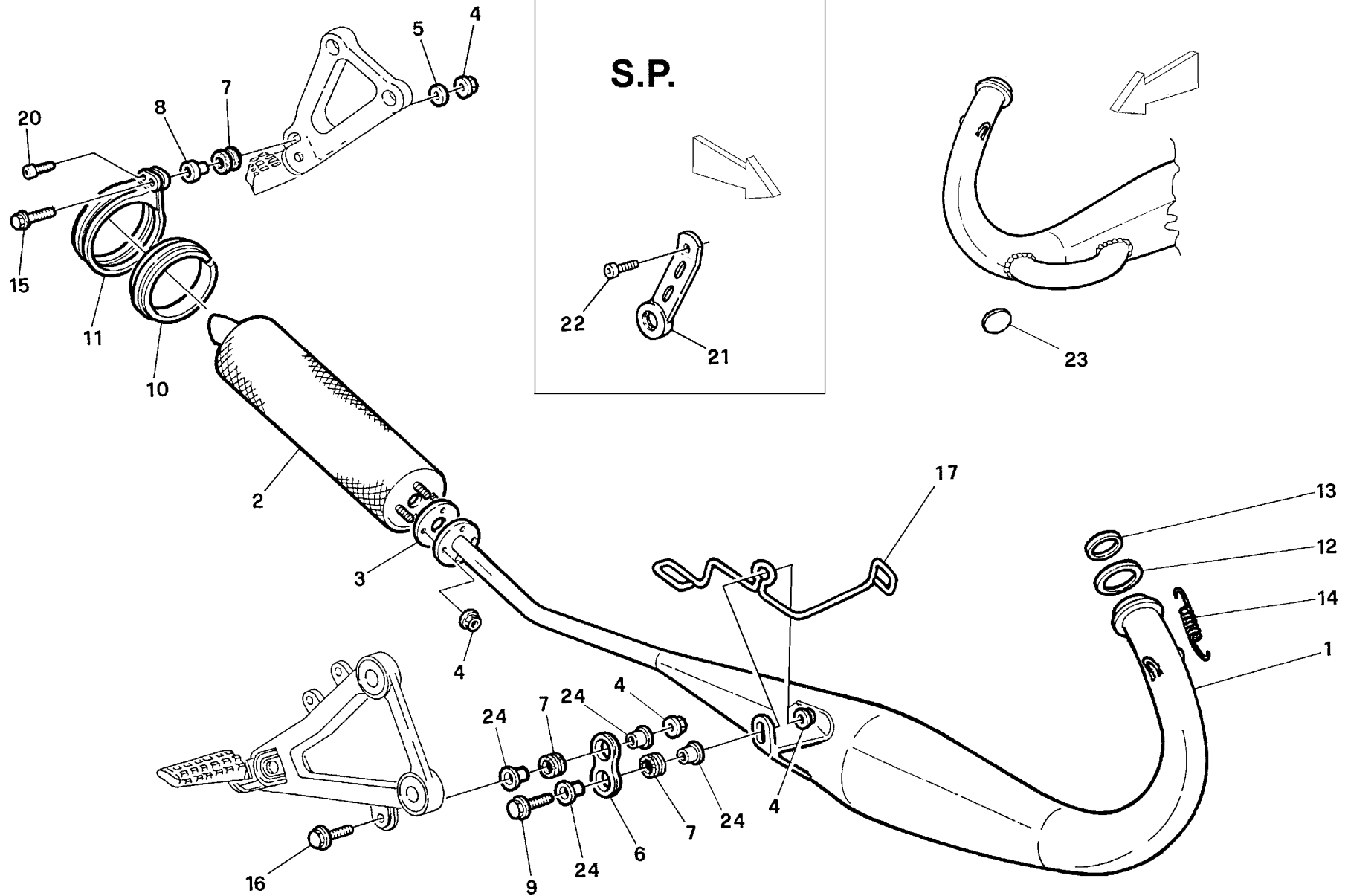

Note Notes Marken Notas	Pos. No. Index Pos.	N. Cod. Code No. Nr. Code Code Nr N. Cod.	Q.tà Q.ty Q.te M.ge C.ad	DENOMINAZIONE	NAME	DESIGNATION	BESHREIBUNG	DENOMINACION	Validità Validity Validité Gültig Valides
KZ	22	8A00 67545	1	Vite	Screw	Vis	Schraube	Tornillo	
P	23	8000 94147	1	Fondello	Plug	Bouchon	Verschluss	Tapòn	
	24	8000 95567	4	Distanziale	Spacer	Entretoise	Distanzstück	Separadòr	
K				A richiesta per kit S.P. '99 cod. 800092789	Upon request for S.P. kit '99 code 800092789	Sur demande pour set S.P. '99 code 800092789	Auf Anfrage für Kit S.P. '99 Code 800092789	Bajo pedido por kit S.P. '99 cod. 800092789	
Z				A richiesta per kit S.P. '01 cod. 800097946	Upon request for S.P. kit '01 code 800097946	Sur demande pour set S.P. '01 code 800092789	Auf Anfrage für Kit S.P. '01 Code 800097946	Bajo pedido por kit S.P. '01 cod. 800097946	
P				Kit potenziamento N. 800093893	Kit poweri No 800093893	Kit de poissance Nr 800093893	Kit Potenz Nr 800093893	Kit Potencia N. 800093893	

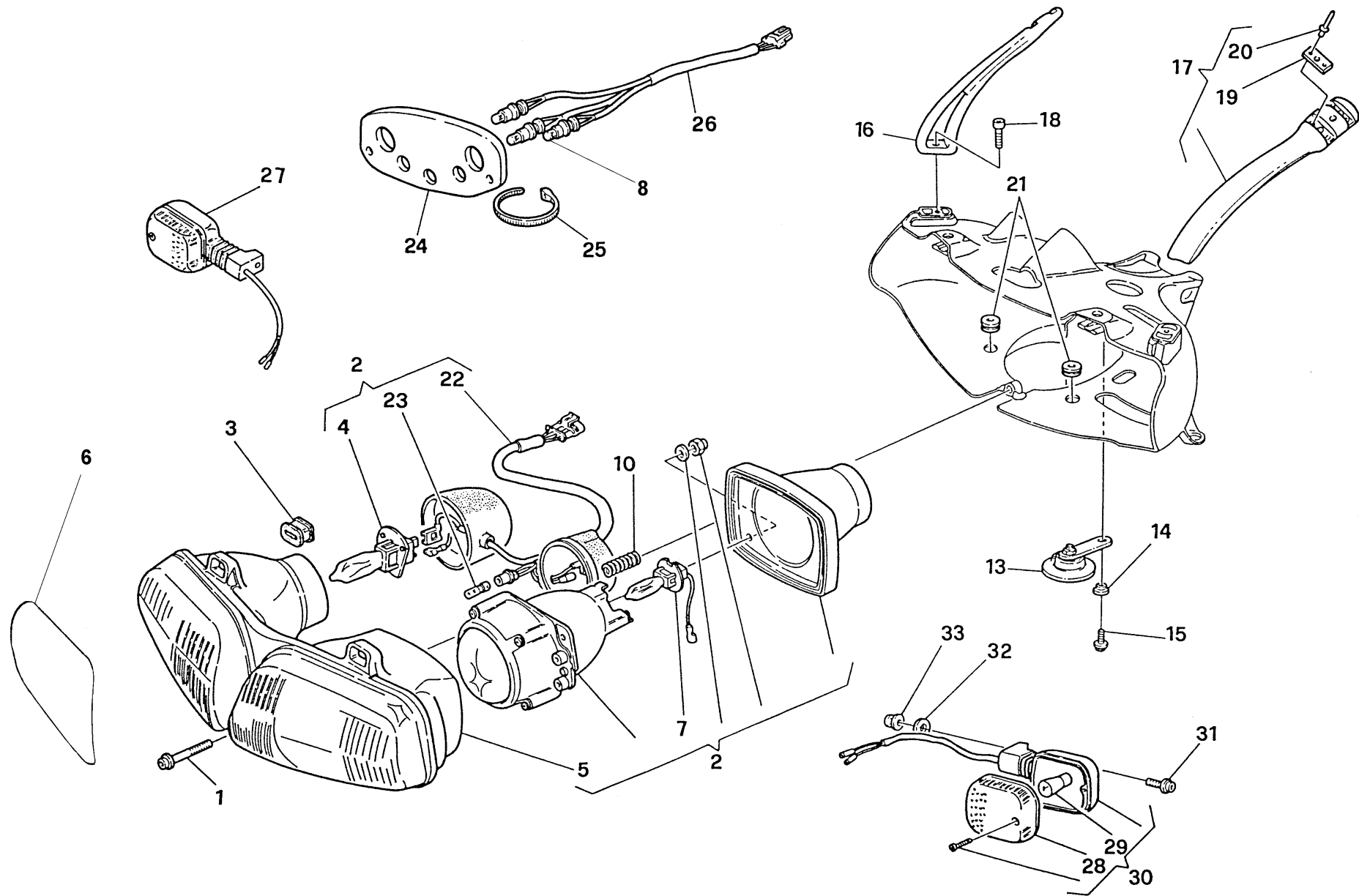

**FARO ANTERIORE / HEADLAMP-FRONT  
FHARE-AVANT / SCHEINWERFER-VORDER  
FARO DELANTERO**

Note Notes Notas	Pos. No. Index Pos.	N. Cod. Code No. Nr. Code Code Nr N. Cod.	Q.tà Q.ty Q.te M.ge C.ad	DENOMINAZIONE	NAME	DESIGNATION	BESHREIBUNG	DENOMINACION	Validità Validity Validité Gültig Valides
	1	8M00 90425	1	Vite	Screw	Vis	Schraube	Tornillo	
	2	8000 77899	1	Gruppo ottico anteriore compl.	Optical group	Groupe optique	Optische Gruppe	Grupo óptico	
	2	8000 79680	1	Gruppo ottico anteriore (GB - AUS)	Optical group (GB - AUS)	Groupe optique (GB - AUS)	Optische Gruppe (GB - AUS)	Grupo óptico (GB - AUS)	
Q	2	8000 79680	1	Gruppo ottico anteriore (INA - MAL - ZA)	Optical group (INA - MAL - ZA)	Groupe optique (INA - MAL - ZA)	Optische Gruppe (INA - MAL - ZA)	Grupo óptico (INA - MAL - ZA)	
	3	7001 0201A	2	Silent block	Silent block	Silent block	Silentblock	Silentblock	
	4	8000 79672	1	Lampada biluce	Lamp	Lampe	Lampe	Lamparilla	
	5	8000 79674	1	Corpo riflettori con vetri	Bady reflettör	Phare	Scheinwefer	Faro	
KZ	6	8000 74190	2	Decal oscuramento	Transfer	Dècal	Abziehbilder	Calcomania	
	7	8000 79673	1	Lampada	Lamp	Lampe	Lampe	Lamparilla	
KZ	8	8000 60033	3	Lampada 12v-3w	Lamp	Lampe	Lampe	Lamparilla	
	10	7991 0641A	1	Molla	Spring	Ressort	Feder	Resorte	
	13	5164 0011A	1	Avvisatore acustico	Horn	Signal acoustique	Hupe	Avisador acustico	
A	13	8000 A0512	1	Avvisatore acustico	Horn	Signal acoustique	Hupe	Avisador acustico	
	14	8000 78346	1	Distanziale	Spacer	Entretoise	Distanzstück	Separador	
	15	8000 62727	1	Vite	Screw	Vis	Schraube	Tornillo	
	16	8000 77772	1	Assieme supporto DX	R. support compl.	Support compl. G.	Halter klp. R	Soporte compl. D.	
	17	8000 77773	1	Assieme supporto SX	L. support compl.	Support compl. G.	Halter klp. L.	Soporte compl. I.	
	18	8D00 90425	2	Vite	Screw	Vis	Schraube	Tornillo	
	19	8000 66336	4	Molletta	Spring	Ressort	Feder	Resorte	
	20	8000 33377	8	Rivetto	Rivet	Rivet	Niet	Remache	
	21	8000 41862	2	Passacavo	Fairlead	Passe-cable	Labelführung	Prensa-cable	
	22	8000 78342	1	Gruppo cavi	Cable	Cables	Kabel	Grupo cables	
	23	8000 36230	1	Lampada città	Lamp	Lampe	Lampe	Lamparilla	
KZ	24	8000 73113	1	Supporto	Support	Support	Halterung	Soporte	
KZ	25	8000 56783	2	Fascetta	Clamp	Collier	Schelle	Abrazadera	
KZ	26	8000 79039	1	Cablaggio	Cable	Cables	Kabel	Grupo cables	
	27	8000 78337	1	Indicatore di direz. ant. DX	Blinker	Clignotant	Blinker	Intermitente	
	28	8000 74507	2	Lente	Lens	Loupe	Linse	Lente	
	29	8000 36726	2	Lampada	Lamp	Lampe	lampe	Lamparilla	
	30	8000 78338	1	Indicatore di direz. ant. SX	Blinker	Clignotant	Blinker	Intermitente	
	31	8G00 90425	2	Vite	Screw	Vis	Schraube	Tornillo	

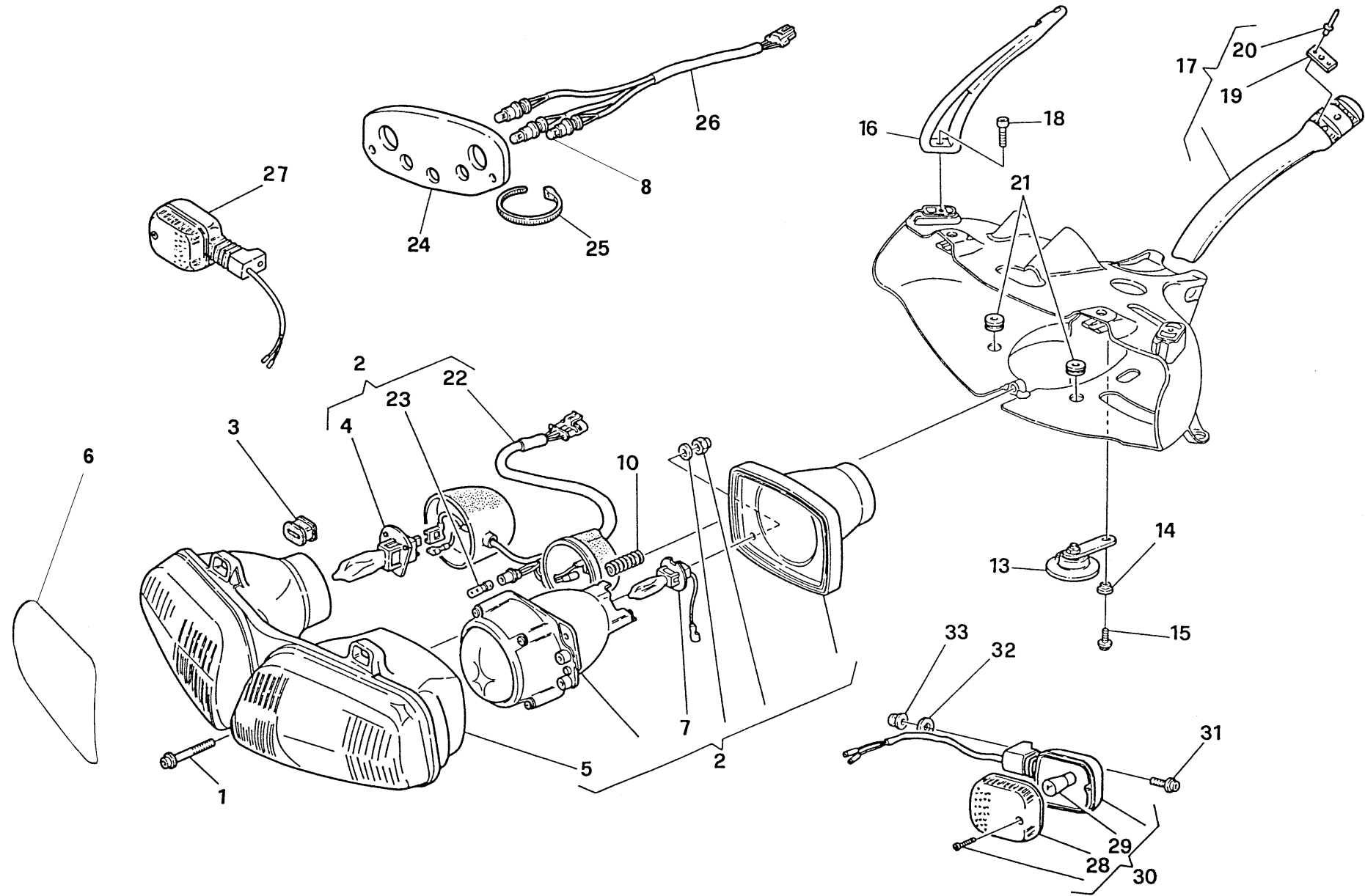

**FARO ANTERIORE / HEADLAMP-FRONT  
 FHARE-AVANT / SCHEINWERFER-VORDER  
 FARO DELANTERO**

Note Notes Notes Marke Notas	Pos. No. N. Index Pos.	N. Cod. Code No. Nr. Code Code Nr N. Cod.	Q.tà Q.ty Q.te M.ge C.ad	DENOMINAZIONE	NAME	DESIGNATION	BESHREIBUNG	DENOMINACION	Validità Validity Validité Gültig Valides
	32	8000 04898	2	Rosetta	Washer	Rondelle	Scheibe	Arandela	
	33	8000 44240	2	Dado	Nut	Ecrou	Mutter	Tuerca	
KZ				A richiesta per kit S.P.	Upon request for S.P. kit	Sur demande pour set S.P.	Auf Anfrage für Kit S.P.	Bajo pedido por kit S.P.	
Q				Versione Piena Potenza	Full power version	Version plein puissance	Version Plus Potenz	Versión potencia plena	

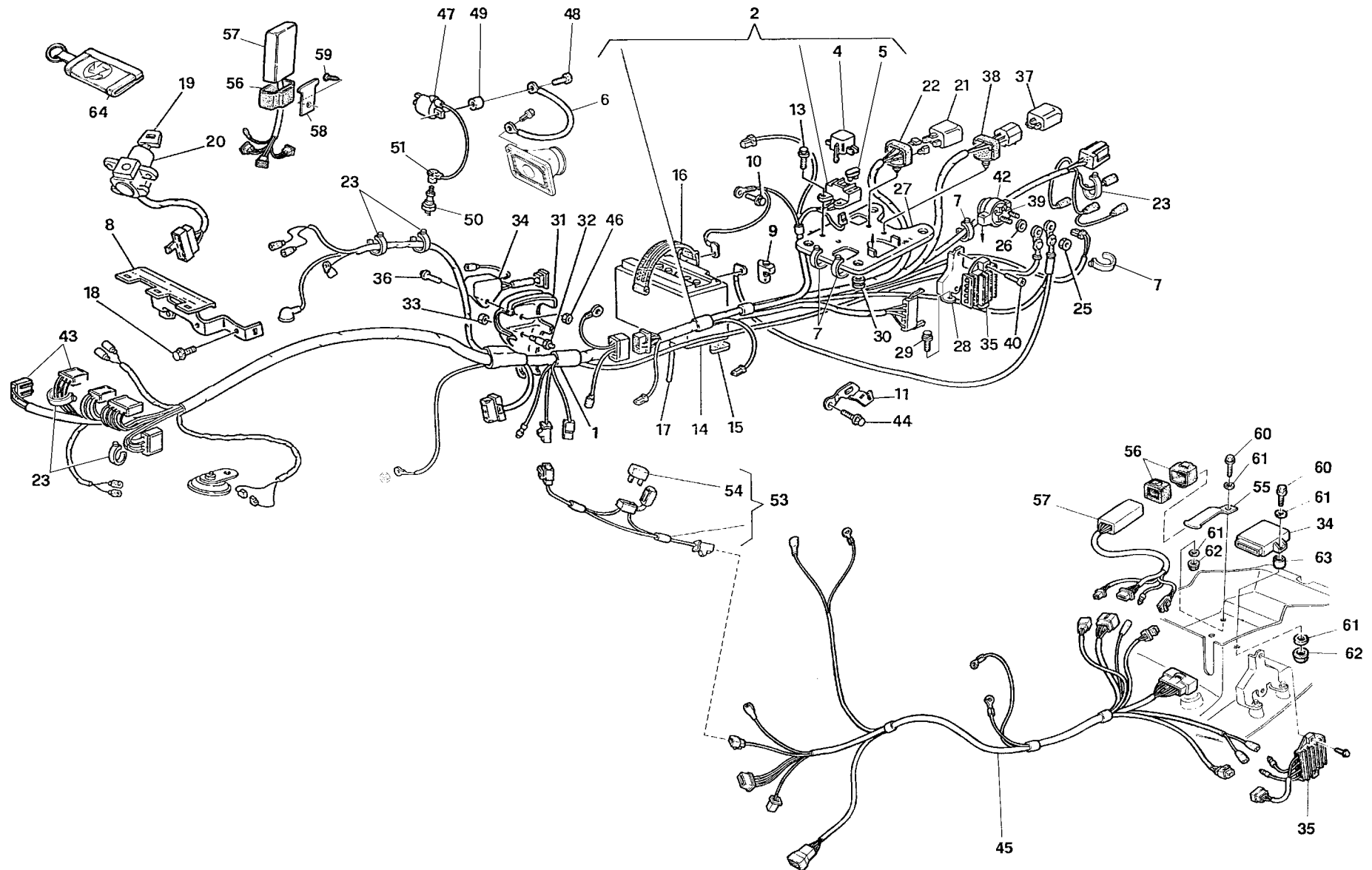



**IMPIANTO ELETTRICO - ELECTRIC SYSTEM  
INSTALLATION ELECTRIQUE - ELEKTRISCHE ANLAGE  
INSTALACION ELECTRICA**

Note Notes Marka Notas	Pos. No. Index Pos.	N. Cod. Code No. Nr. Code N. Cod.	Q.tà Q.ty Q.te M.ge C.ad	DENOMINAZIONE	NAME	DESIGNATION	BESHREIBUNG	DENOMINACION	Validità Validity Validité Gültig Valides
	1	8000 77894	1	Gruppo cavi anteriore	Cable	Cables	Kabel	Grupo cables	
	2	8A00 77895	1	Gruppo cavi	Cable	Cables	Kabel	Grupo cables	
	4	8000 49887	1	Coperchietto	Cover	Couvercle	Deckel	Tapa	
	5	8000 47472	4	Fusibile 15A	Fuse	Fusible	Sicherung	Fusible	
	6	8000 94600	1	Cavo	Cable	Cables	Kabel	Grupo cables	
	7	8000 56444	4	Fascetta	Clamp	Collier	Schelle	Banda	
	8	8000 78180	1	Supporto connettori	Support	Support	Halterung	Soporte	
	9	8000 78350	1	Cappuccio	Cap	Capuchon	Kappe	Capuchon	
	10	8000 62725	1	Vite	Screw	Vis	Schraube	Tornillo	
	11	8000 78213	1	Supporto	Support	Support	Halterung	Soporte	
	13	8000 66525	2	Vite	Screw	Vis	Schraube	Tornillo	
	14	8000 99676	1	Batteria + istruzioni	Battery + instructions	Batterie + instructions	Batterie + Anweisung	Batería + intrucciones	
	15	8000 66339	4	Tampone	Pad	Tampon	Stopfen	Tampón	
	16	8000 66340	1	Cinghietta	Belt	Courroie	Riemen	Correa	
	17	8B00 66536	1	Sfiato	Breather pipe	Évent	Entlüfter	Purga	
	18	60N1 02482	4	Vite	Screw	Vis	Schraube	Tornillo	
	19	8000 66159	1	Chiave grezza	Key	Clé	Schüssel	Llave	
	20	8000 77770	1	Interruttore accensione	Switch	Interrupteur	Schalter	Interruptor	
	21	8000 88173	1	Intermittenza indicat. di direz.	Flash device	Intermittence	Blinkgeber	Intermitencia	
	22	8000 67548	1	Supporto elastico	Support	Support	Halterung	Soporte	
	23	8000 53724	5	Fascetta in gomma	Clamp	Collier	Schelle	Banda	
	25	61N1 15062	1	Dado	Nut	Ecrou	Mutter	Tuerca	
	26	62N1 15767	2	Rondella elastica	Washer	Rondelle	Scheibe	Arandela	
	27	8000 62677	1	Pannello posteriore	Panel	Panneau	Streifen	Panel	
	28	8000 78174	1	Supporto regolatore	Support	Support	Halterung	Soporte	
	29	8000 62725	2	Vite	Screw	Vis	Schraube	Tornillo	
	30	8000 62645	4	Piolo elastico	Elastic peg	Échelon élastique	Elastischer Zapfen	Espiga elástica	
	31	8000 67949	1	Coperchietto	Cover	Couvercle	Deckel	Tapa	
	32	8000 67948	1	Perno	Pin	Pivot	Bolzen	Perno	
	33	8000 56443	1	Dado	Nut	Ecrou	Mutter	Tuerca	
	34	8000 59394	1	Centralina elettronica	Electronic device	Dispositif électronique	Zündelektronik	Centralita electrónica	
K	34	8000 92404	1	Centralina elettronica	Electronic device	Dispositif électronique	Zündelektronik	Centralita electrónica	
Z	34	8000 97725	1	Centralina elettronica	Electronic device	Dispositif électronique	Zündelektronik	Centralita electrónica	

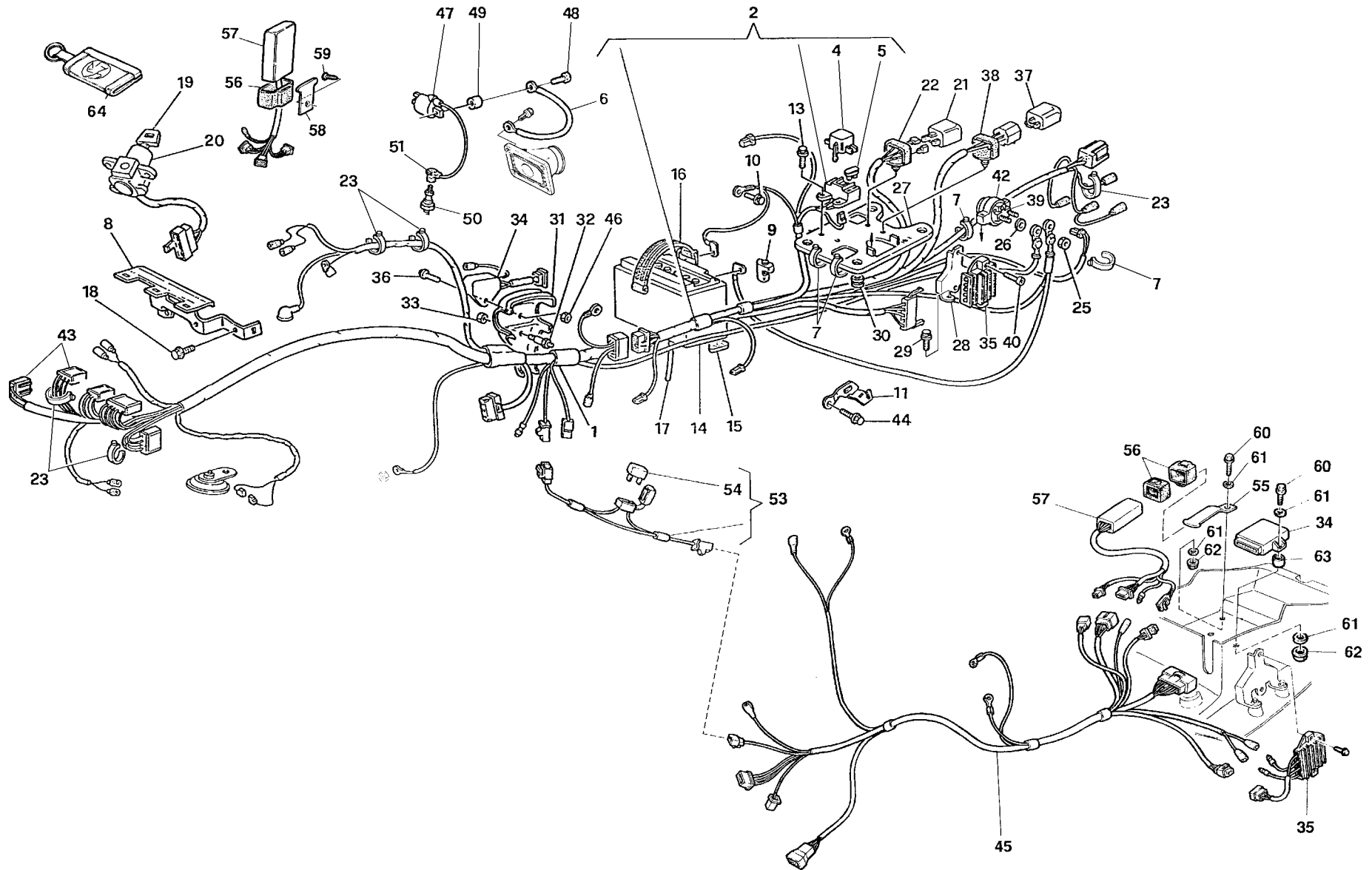

**IMPIANTO ELETTRICO - ELECTRIC SYSTEM  
INSTALLATION ELECTRIQUE - ELEKTRISCHE ANLAGE  
INSTALACION ELECTRICA**

Note Notes Marke Notas	Pos. No. Index Pos.	N. Cod. Code No. Nr. Code Code Nr N. Cod.	Q.tà Q.ty Q.te M.ge C.ad	DENOMINAZIONE	NAME	DESIGNATION	BESHREIBUNG	DENOMINACION	Validità Validity Validité Gültig Valides
	35	8000 42274	1	Regolatore di tensione	Voltage rectifier	Régulateur de tension	Spannungsregler	Regulador de tensión	
KZ	35	8000 92402	1	Regolatore di tensione	Voltage rectifier	Régulateur de tension	Spannungsregler	Regulador de tensión	
	36	8000 62726	1	Vite	Screw	Vis	Schraube	Tornillo	
	37	8000 89846	1	Centralina avviamento	Starting system	Distributeur démarrage	Elektronik für Anlass	Centralita arranque	
	38	8000 67548	1	Supporto elastico	Support	Support	Halterung	Soporte	
	39	3974 0011A	1	Teleruttore avviamento	Solenoid starter	Télérupteur démarrage	Fernschlater für das	Telerruptor arranque	
	40	8000 62727	2	Vite	Screw	Vis	Schraube	Tornillo	
	42	8000 66803	1	Supporto	Support	Support	Halterung	Soporte	
	44	8000 62725	2	Vite	Screw	Vis	Schraube	Tornillo	
KZ	45	8000 92313	1	Gruppo cavi S.P.	Cable S.P.	Cables S.P.	Kabel S.P.	Grupo cables S.P.	
	46	8000 44240	1	Dado	Nut	Ecrou	Mutter	Tuerca	
	47	8A00 42272	1	Bobina	Coil	Bobine	Zündspule	Bobina	
KZ	47	8000 72887	1	Bobina	Coil	Bobine	Zündspule	Bobina	
	48	8BA0 37390	2	Vite	Screw	Vis	Schraube	Tornillo	
	49	8A00 48889	2	Distanziale	Spacer	Entretoise	Distanzstück	Separador	
	50	8A00 57446	1	Candela NGK BR 9 EG	Spark plug BR 9 EG	Bougie BR 9 EG	Zündkerze BR 9 EG	Bujía BR 9 EG	
H	50	8000 88759	1	Candela CHAMPION QN 84	Spark plug QN 84	Bougie QN 84	Zündkerze QN 84	Bujía QN 84	
KZ	50	8000 91875	1	Candela NGK B 10,5 EGV	Spark plug B 10,5 EGV	Bougie B 10,5 EGV	Zündkerze B 10,5 EGV	Bujía B 10,5 EGV	
	51	8000 75270	1	Pipetta schermata	Pipette	Pipette	Pipette	Pipa	
H	51	8000 90877	1	Pipetta schermata	Pipette	Pipette	Pipette	Pipa	
H	51	8000 97295	1	Pipetta schermata	Pipette	Pipette	Pipette	Pipa	
	53	8000 90582	1	Cavo	Cable	Cable	Kabel	Cable	
	54	8000 47467	1	Fusibile	Fuse	Fusible	Sicherung	Fusibile	
KZ	55	8000 89038	1	Piastrina	Plate	Plaque	Platte	Placa	
	56	8000 86751	1	Supporto elastico	Support	Support	Halterung	Soporte elástico	
KZ	56	8000 86751	1	Supporto elastico	Support	Support	Halterung	Soporte elástico	
	57	8000 86750	1	Controllo apertura valvola	Valve opening control	Contrôle d'ouvert. clapet	Kontrolle ventil Oeffnung	Control apertura valvula	
KZ	57	8000 93061	1	Controllo apertura valvola	Valve opening control	Contrôle d'ouvert. clapet	Kontrolle ventil Oeffnung	Control apertura valvula	
	58	8000 62743	1	Piastrina	Plate	Plaque	Platte	Placa	
	59	8000 58806	1	Vite	Screw	Vis	Schraube	Tornillo	
KZ	60	8000 62727	3	Vite	Screw	Vis	Schraube	Tornillo	
KZ	61	62N1 15549	6	Rosetta	Washer	Rondelle	Scheibe	Arandela	
KZ	62	8000 44240	3	Dado	Nut	Ecrou	Mutter	Tuerca	

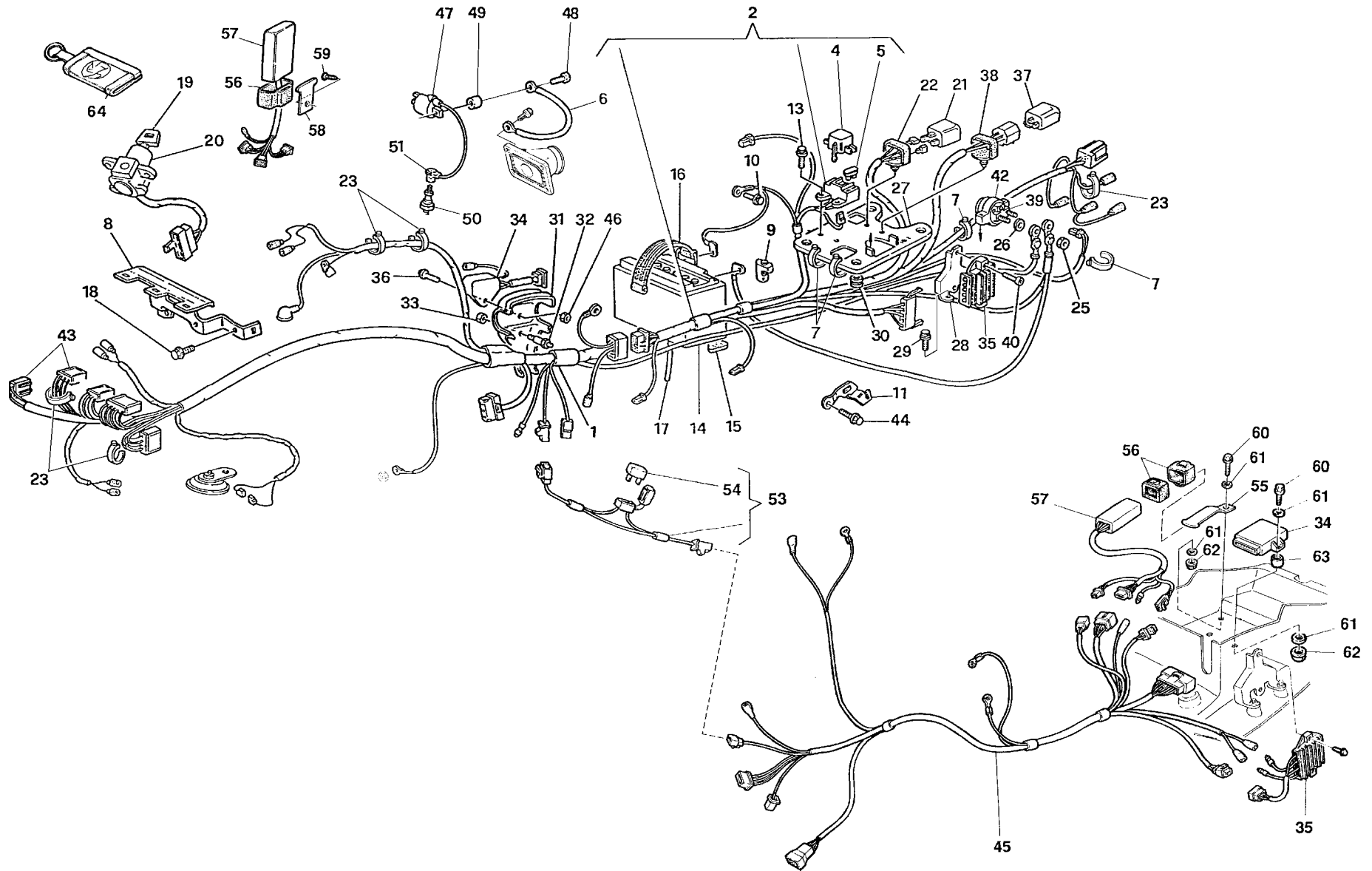

**IMPIANTO ELETTRICO - ELECTRIC SYSTEM  
INSTALLATION ELECTRIQUE - ELEKTRISCHE ANLAGE  
INSTALACION ELECTRICA**

Note Notes Marke Notas	Pos. No. Index Pos.	N. Cod. Code No. Nr. Code Code Nr N. Cod.	Q.tà Q.ty M.ge C.ad	DENOMINAZIONE	NAME	DESIGNATION	BESHREIBUNG	DENOMINACION	Validità Validity Validité Gültig Valides
KZ	63	8000 90012	2	Antivibrante	Rubber	Pièce caoutchouc	Gummistück	Junta de goma	
	64	8000 96516	1	Portachiavi	Keyring	Porteclefs	Schlüsselring	Llavero	
K				A richiesta per kit S.P. '99 cod. 800092789	Upon request for S.P. kit '99 code 800092789	Sur demande pour set S.P. '99 code 800092789	Auf Anfrage für Kit S.P. '99 Code 800092789	Bajo pedido por kit S.P. '99 cod. 800092789	
Z				A richiesta per kit S.P. '01 cod. 800097946	Upon request for S.P. kit '01 code 800097946	Sur demande pour set S.P. '01 code 800092789	Auf Anfrage für Kit S.P. '01 Code 800097946	Bajo pedido por kit S.P. '01 cod. 800097946	
H				In alternativa	In alternative	En alternative	Wahlweise	En alternativa	

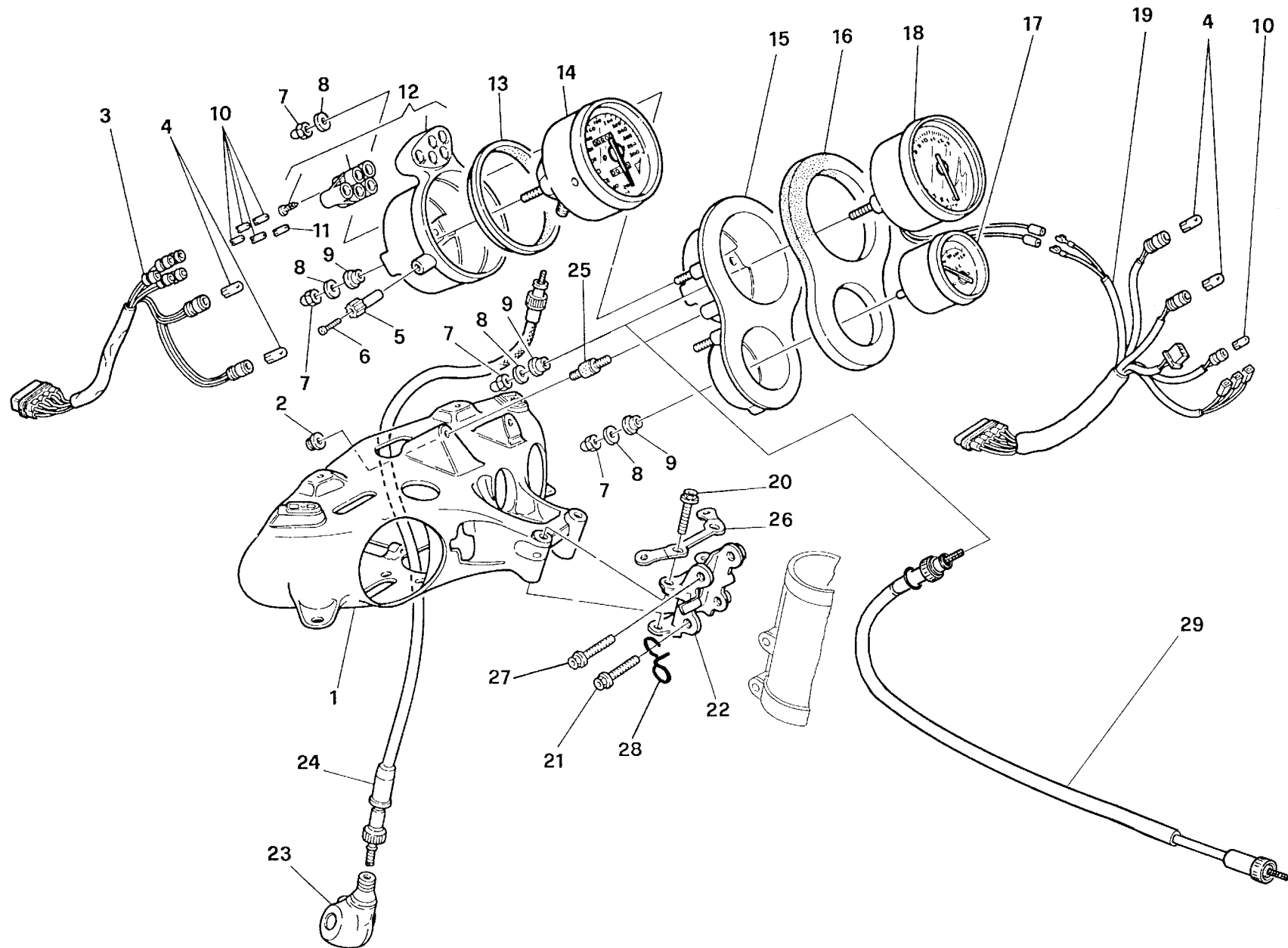

Note Notes Notas	Pos. No. Index Pos.	N. Cod. Code No. Nr. Code Code Nr N. Cod.	Q.tà Q.ty Q.te M.ge C.ad	DENOMINAZIONE	NAME	DESIGNATION	BESHREIBUNG	DENOMINACION	Validità Validity Validité Gültig Valides
	1	82911121AB	1	Supporto	Support	Support	Halter	Soporte	
	2	8000 42278	3	Dado	Nut	Ecrou	Mutter	Tuerca	
	3	8000 77938	1	Impianto fili	Wiring	Câblage	Verdrahtung	Instalación hilos	
	4	8000 56750	4	Lampada strumenti	Lamp	Lampe	Lampe	Lamparilla	
	5	8000 56742	1	Manopola trip / odometro	Handle	Poignée	Lenker	Botón trip/odómetro	
	6	8000 56465	1	Vite	Screw	Vis	Schraube	Tornillo	
	7	8000 56748	7	Dado	Nut	Ecrou	Mutter	Tuerca	
	8	8000 56747	7	Rondella piana	Washer	Rondelle	Unterlegscheibe	Arandela plana	
	9	8000 56746	5	Antivibrante	Silent block	Antivibration	Schwingungsdämpfer	Anti vibrador	
	10	8000 20602	5	Lampada spie	Lamp	Lampe	Lampe	Lamparilla	
	11	8000 65318	1	Lampada spia benzina	Fuel lamp	Lampe fuel	Lampe fuel	Lamparilla fuel	
	12	8000 78347	1	Supporto contachilometri	Support	Support	Halterung	Soporte	
	13	8000 56741	1	Guarnizione	Gasket	Garnitue	Dichtung	Junta	
	14	8000 94346	1	Contachilometri	Odometer	Compteur Km.	Kilometerzähler	Cuenta Kilometros	
	15	8000 78348	1	Supporto contagiri	Support	Support	Halterung	Soporte	
	16	8000 77936	1	Guarnizione	Gasket	Garnitue	Dichtung	Junta	
	17	8000 77935	1	Termometro	Thermometer	Termomètre	Thermometer	Termómetro	
	18	8000 77934	1	Contagiri	Rev. counter	Compte tours	Drehzahlmesser	Cuenta revoluciones	
KZ	18	8000 66366	1	Contagiri	Rev. counter	Compte tours	Drehzahlmesser	Cuenta revoluciones	
	19	8000 77937	1	Impianto fili	Wiring	Câblage	Verdrahtung	Instalación hilos	
	20	8D00 67545	2	Vite	Screw	Vis	Schraube	Tornillo	
	21	8000 62731	1	Vite	Screw	Vis	Schraube	Tornillo	
	22	8000 70172	1	Attacco	Connection	Attaque	Anschluss	Conexion	
	23	8000 78336	1	Rinvio contachilometri	Odometer transm.	Renvoi compte km.	Vorgelege Kilometerzähler	Reenvío cuenta kilómetros	
	24	8000 70130	1	Trasmissione contachilometri	Speedometer cable	Câble compteur km	Tachokabel	Cable cuenta kilómetros	
	25	8000 56752	3	Antivibrante	Silent block	Antivibration	Schwingungsdämpfer	Anti vibrador	
	26	8000 78206	1	Supporto paratie paraspruzzi	Support	Support	Halter	Soporte	
	27	8E00 67545	2	Vite	Screw	Vis	Schraube	Tornillo	
	28	8000 80453	1	Passacavo	Fairlead	Passe-câble	Kabelführung	Prensa-cable	
K				A richiesta per kit S.P. '99 cod. 800092789	Upon request for S.P. kit '99 code 800092789	Sur demande pour set S.P. '99 code 800092789	Auf Anfrage für Kit S.P. '99 Code 800092789	Bajo pedido por kit S.P. '99 cod. 800092789	
Z				A richiesta per kit S.P. '01 cod. 800097946	Upon request for S.P. kit '01 code 800097946	Sur demande pour set S.P. '01 code 800092789	Auf Anfrage für Kit S.P. '01 Code 800097946	Bajo pedido por kit S.P. '01 cod. 800097946	

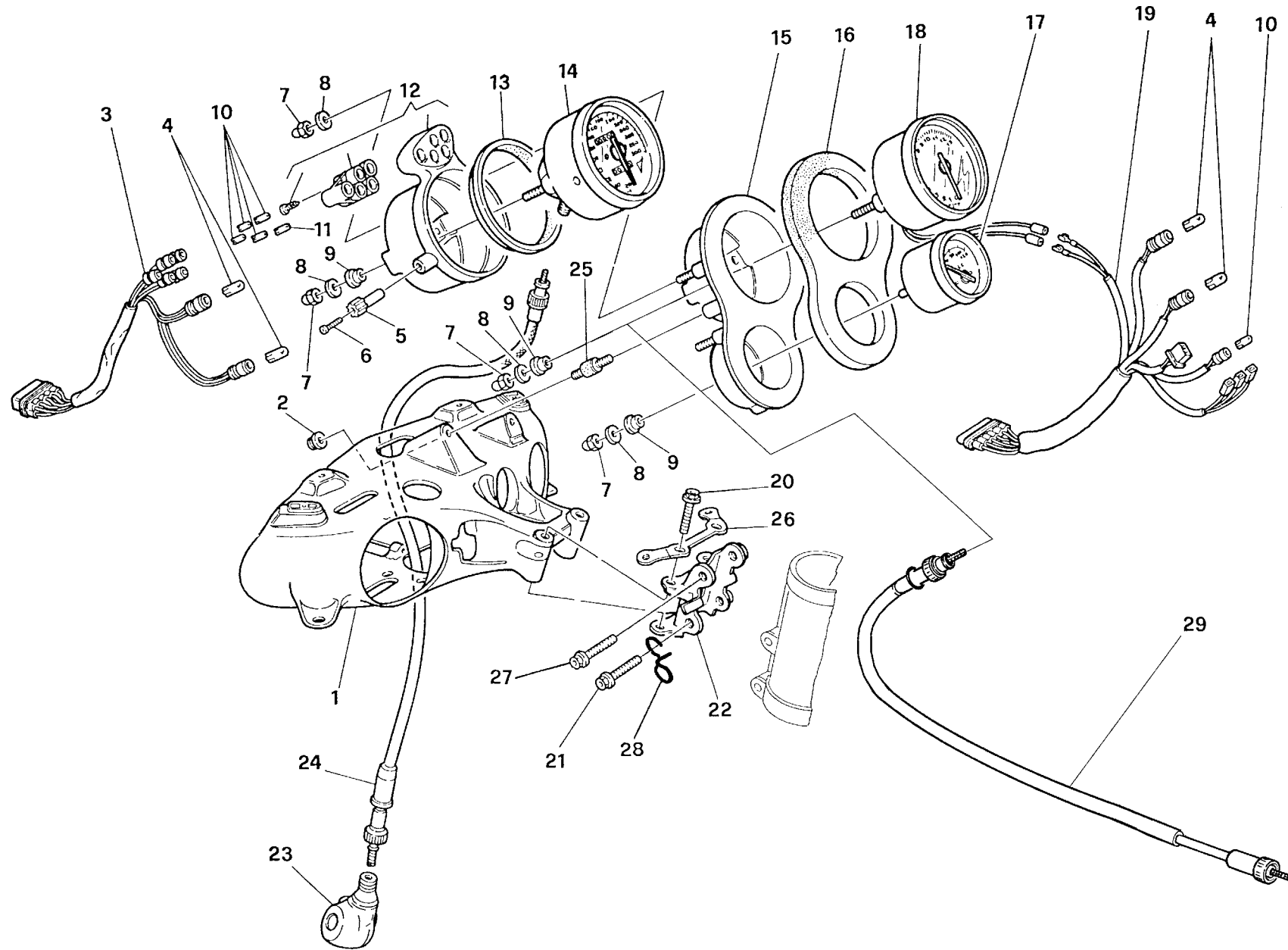



**STRUMENTI - INSTRUMENTS  
INSTRUMENTS - INSTRUMENTE  
INSTRUMENTOS**

Note Notes Marke Notas	Pos. No. Index Pos.	N. Cod. Code No. Nr. Code Code Nr N. Cod.	Q.tà Q.ty Q.te M.ge C.ad	DENOMINAZIONE	NAME	DESIGNATION	BESHREIBUNG	DENOMINACION	Validità Validity Validité Gültig Valides
KZ	29	8A00 66492	1	Trasmissione contagiri	Odometer cable	Câble compte tours	Drehzahlmesser kabel	Cable cuenta revoluciones	
K				A richiesta per kit S.P. '99 cod. 800092789	Upon request for S.P. kit '99 code 800092789	Sur demande pour set S.P. '99 code 800092789	Auf Anfrage für Kit S.P. '99 Code 800092789	Bajo pedido por kit S.P. '99 cod. 800092789	
Z				A richiesta per kit S.P. '01 cod. 800097946	Upon request for S.P. kit '01 code 800097946	Sur demande pour set S.P. '01 code 800092789	Auf Anfrage für Kit S.P. '01 Code 800097946	Bajo pedido por kit S.P. '01 cod. 800097946	

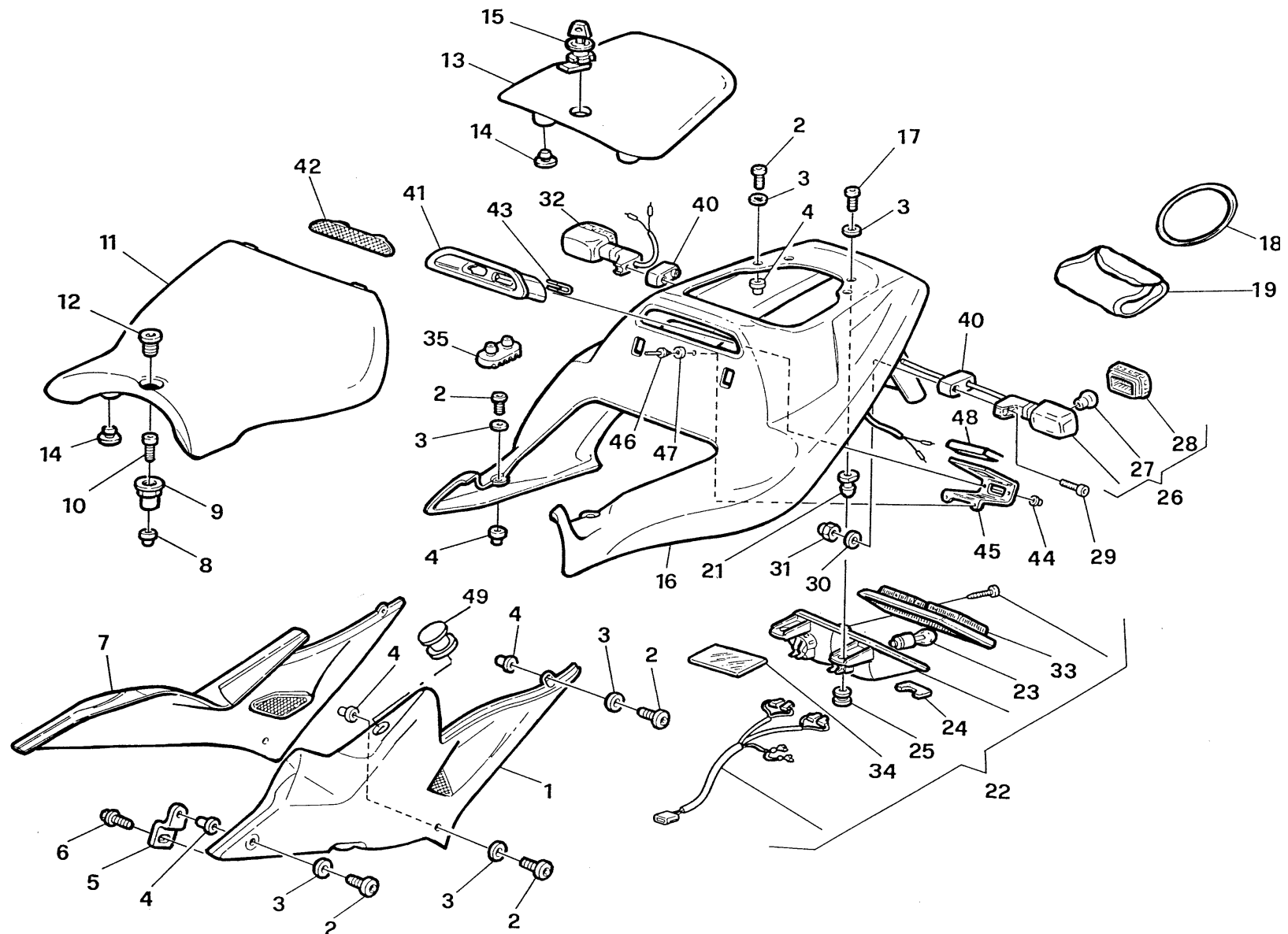

**CARENATURA POSTERIORE - REAR FAIRING  
CARENAGE POST. - HINTERSCHALE  
CARROCERIA TRASERA**

Note Notes Notas	Pos. No. Index Pos.	N. Cod. Code No. Nr. Code Code Nr N. Cod.	Q.tà Q.ty Q.te M.ge C.ad	DENOMINAZIONE	NAME	DESIGNATION	BESHREIBUNG	DENOMINACION	Validità Validity Validité Gültig Valides
	1	8000 92333	1	Fianchetto Sx (cod.col. B-E-F=8E60)	L. side (colour code B-E-F=8E60)	Flanc G. (code couleur B-E-F=8E60)	Wange L. (Color Farbe B-E-F=8E60)	Lateral iz. (cód.col. B-E-F=8E60)	
	2	80C0 55698	10	Vite	Screw	Vis	Schraube	Tornillo	
	3	8000 56391	10	Rosetta in nylon	Washer	Rondelle	Scheibe	Arandela	
	4	8000 48245	10	Dado	Nut	Ecrou	Mutter	Tuerca	
	5	8000 77756	2	Piastrina	Plate	Plaquette	Plättchen	Placa	
	6	8000 62726	2	Vite	Screw	Vis	Schraube	Tornillo	
	7	8000 92332	1	Fianchetto Dx (cod.col. B-E-F=8E60)	R. side (colour code B-E-F=8E60)	Flanc D. (code couleur B-E-F=8E60)	Wange R. (Color Farbe B-E-F=8E60)	Lateral der. (cód.col. B-E-F=8E60)	
	8	8000 48245	1	Dado	Nut	Ecrou	Mutter	Tuerca	
	9	8000 78176	1	Distanziale	Spacer	Entretoise	Distanzstück	Separador	
	10	8BA0 67545	1	Vite	Screw	Vis	Schraube	Tornillo	
	11	8000 77927	1	Sella pilota completa	Seat	Siège	Sattel	Sillín	
	12	8000 78177	1	Dado	Nut	Ecrou	Mutter	Tuerca	
	13	8A00 77929	1	Sellino (cod.col. A-D=nero)	Pass.saddle(col.cod.A-D=black)	Selle pass.(cod.col. A-D=noir)	Beifahrersattel (Code Farbe A-D=Schwarz)	Sillín pas.(cod.col. A-D=negro)	
	13	8B00 77929	1	Sellino (cod.col. B-C=rosso)	Pass.saddle(col.cod.B-C red)	Selle pass.(cod.col. B-C=rouge)	Beifahrersattel(C.Farb.B-C=Rot)	Sillín pas. (cod.col. B C=rojo)	
	14	8000 41039	6	Tampone	Pad	Tampon	Stopfen	Tampón	
	15	8000 66156	1	Serratura con chiavi	Lock with keys	Serrure avec clés	Schloss mit Schlüssel	Cerradura con llaves	
	16	8000 92335	1	Codone (Cod. colore B=8G59)	Tail (color code B=8G59)	Queu (code couleur B=8G59)	Heck (code Farbe B=8G59)	Cola (código color B=8G59)	
	16	80A0 94053	1	Codone (Cod. colore E=8G63)	Tail (color code E=8G63)	Queu (code couleur E=8G63)	Heck (code Farbe E=8G63)	Cola (código color E=8G63)	
	16	80B0 94053	1	Codone (Cod. colore F=8F03)	Tail (color code F=8F03)	Queu (code couleur F=8F03)	Heck (code Farbe F=8F03)	Cola (código color F=8F03)	
	17	8000 55703	2	Vite	Screw	Vis	Schraube	Tornillo	
	18	8000 78178	1	Elastico	Elastic	Elastique	Elastish	Elastico	
	19	8000 73530	1	Borsa attrezzi	Tool bag	Trousse à outils	Werkzeugtasche	Bolsa herramientas	
	21	8000 77903	2	Piolo	Dowel	Pivot	Zapfen	Clavija	
	22	8000 77969	1	Ass. fanale posteriore	Rear light assy	Feu AR. compl.	Rücklicht, kpl.	Faro compl.	
	23	8000 18246	2	Lampada biluce	Lamp	Lampe	Lampe	Lamparilla	
	24	8000 77898	1	Antivibrante	Silent block	Antivibration	Schwingungsdämpfer	Anti vibrador	
	25	8000 62651	2	Silentblock	Silentblock	Silentblock	Silentblock	Silentblock	
	26	8000 78340	1	Indicat. di direz. poster. sinistro	Blinker	Clignotant	Blinker	Intermitente	
	27	8000 36726	1	Lampada	Lamp	Lampe	Lampe	Lamparilla	
	28	8000 74507	1	Lente	Lens	Loupe	Linse	Lente	

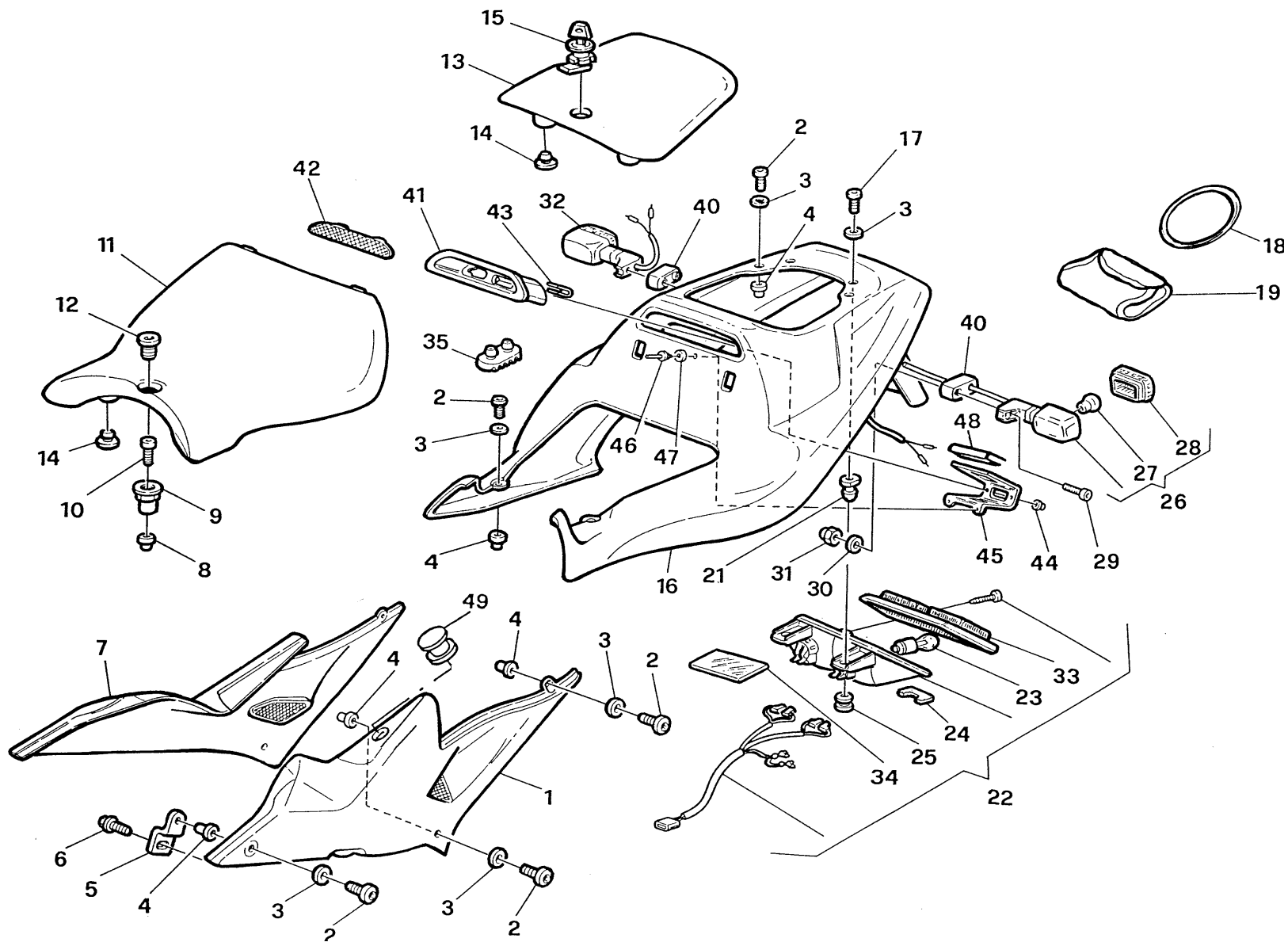

**CARENATURA POSTERIORE - REAR FAIRING  
CARENAGE POST. - HINTERSCHALE  
CARROCERIA TRASERA**

Note Notes Marke Notas	Pos. No. Index Pos.	N. Cod. Code No. Nr. Code Code Nr N. Cod.	Q.tà Q.ty Q.te M.ge C.ad	DENOMINAZIONE	NAME	DESIGNATION	BESHREIBUNG	DENOMINACION	Validità Validity Validité Gültig Valides
	29	60N1 02515	2	Vite	Screw	Vis	Schraube	Tornillo	
	30	8000 04898	2	Rondella piana	Washer	Rondelle	Unterlegscheibe	Arandela plana	
	31	8000 44240	4	Dado	Nut	Ecrou	Mutter	Tuerca	
	32	8000 78339	1	Indicat. di direz. poster. destro	Blinker	Clignotant	Blinker	Intermitente	
	33	8000 72911	1	Lente	Lens	Loupe	Linse	Lente	
	34	8000 72912	1	Lente	Lens	Loupe	Linse	Lente	
	35	8661 0191A	2	Tampone	Pad	Tampon	Stopfen	Tampón	
	40	8C00 69634	2	Distanziale	Spacer	Entretoise	Distanzstück	Separador	
	41	80F0 77951	1	Maniglia (cod. colore B=8E43)	Handle (colour cod. B=8E43)	Poignée (cod. couleur B=8E43)	Handgriff (Cod. Farbe B=8E43)	Manilla (cod. color B=8E43)	
	41	80C0 77951	1	Maniglia (cod. colore E=8G63)	Handle (colour cod. E=8G63)	Poignée (cod. couleur E=8G63)	Handgriff (Cod. Farbe E=8G63)	Manilla (cod. color E=8G63)	
	41	80H0 77951	1	Maniglia (cod. colore F=8F03)	Handle (colour cod. F=8F03)	Poignée (cod. couleur F=8F03)	Handgriff (Cod. Farbe F=8F03)	Manilla (cod. color F=8F03)	
	42	8000 77967	1	Griglia	Grille	Grille	Gitter	Parilla	
	43	8A00 71276	4	Attacco a pinza	Connection	Attaque	Anschluss	Connexion	
	44	8000 44240	2	Dado	Nut	Ecrou	Mutter	Tuerca	
	45	8000 78212	1	Piastra	Plate	Plaque	Platte	Placa	
	46	8000 78210	2	Rivetto	Rivet	Rivet	Niet	Remache	
	47	62N1 15547	2	Rosetta	Washer	Rondelle	Scheibe	Arandela	
	48	8B00 51600	1	Profilo in gomma	Rubber section bar	Profill en caoutchouc	Gummiprofil	Perfil en goma	
	49	8000 69069	2	Gommino	Rubber	Pièce caoutchouc	Gummistück	Goma	

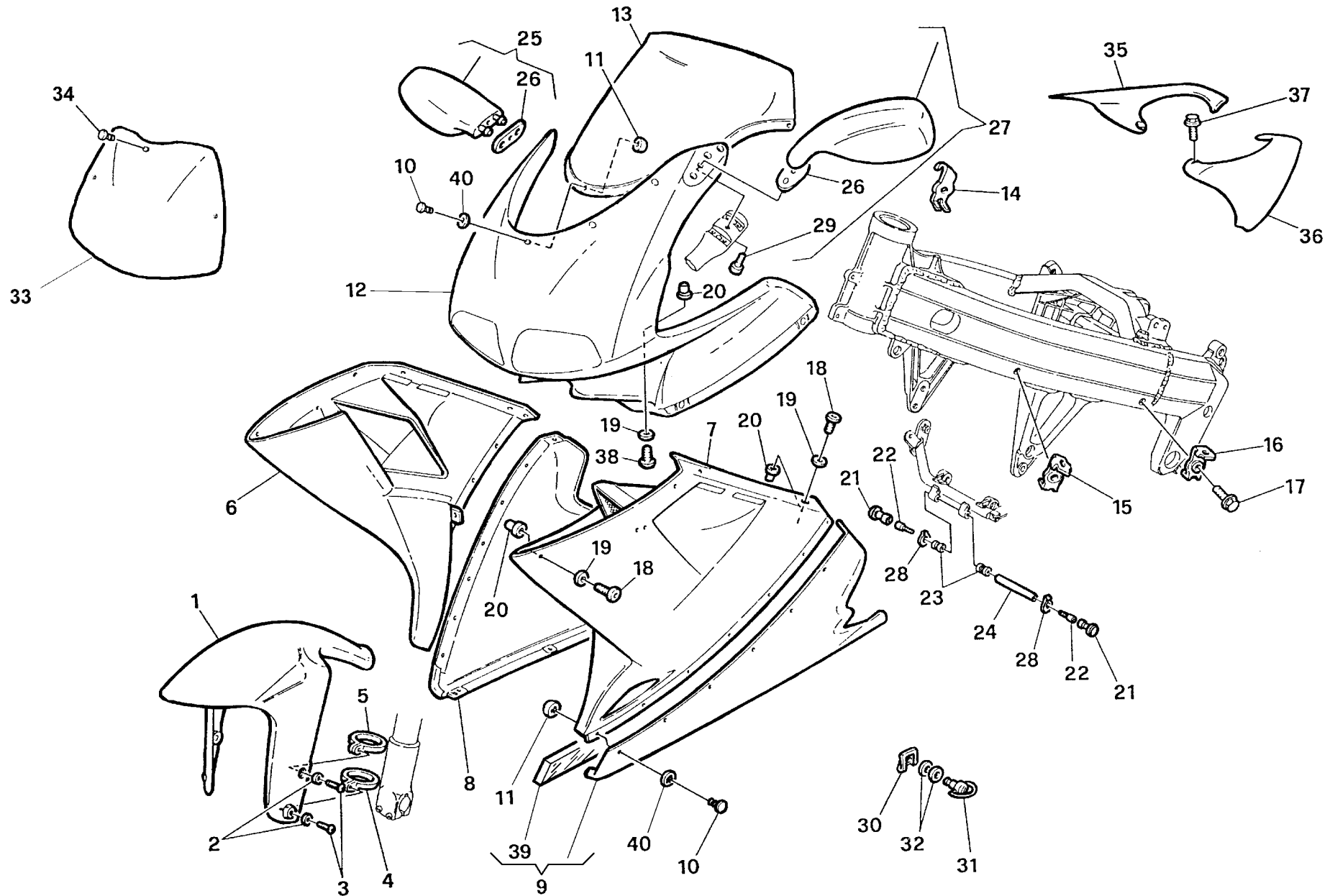

**CARENATURA - FENDERS  
CARENATURE - VERKLEIDUNG  
CARENADO**

Note Notes Markes Notas	Pos. No. N. Index Pos.	N. Cod. Code No. Nr. Code Code Nr C. Cod.	Q.tà Q.ty Q.ite M.ge C.ad	DENOMINAZIONE	NAME	DESIGNATION	BESHREIBUNG	DENOMINACION	Validità Validity Validité Gültig Valides
	1	80F0 70166	1	Parafango anteriore (cod. colore B-E-F=8E60)	Front mudguard (colour code B-E-F=8E60)	Garde boue avant (code couleur B-E-F=8E60)	Vordere Kotfluegel (Code Farbe B-E-F=8E60)	Guardabarros delantero (còd. colòr B-E-F=8E60)	
	2	8000 56391	4	Rondella	Washer	Rondelle	Scheibe	Arandela	
	3	80C0 55698	4	Vite	Screw	Vis	Schraube	Tornillo	
	4	80B0 70133	1	Fascetta	Clamp	Collier	Schelle	Banda	
	5	80B0 70127	3	Fascetta	Clamp	Collier	Schelle	Banda	
	6	8000 92328	1	Fianch. Dx (cod.col. B=8E43)	R. side (color code B=8E43)	Flanc D. (code couleur B=8E43)	Wange R. (Cod.Farbe B=8E43)	Lateral der.(c.color B=8E43)	
	6	80A0 94048	1	Fianch. Dx (cod.col. E=8D83)	R. side (color code E=8D83)	Flanc D. (code couleur E=8D83)	Wange R. (Cod.Farbe E=8D83)	Lateral der.(c.color E=8D83)	
	6	80B0 94048	1	Fianch. Dx (cod.col. F=8F03)	R. side (color code F=8F03)	Flanc D. (code couleur F=8F03)	Wange R. (Cod.Farbe F=8F03)	Lateral der.(c.color F=8F03)	
	7	8000 92329	1	Fianch. Sx (cod.col. B=8E43)	L. side (color code B=8E43)	Flanc G. (code couleur B=8E43)	Wange L.(Cod.Farbe B=8E43)	Lateral iz.(c.color B=8E43)	
	7	80A0 94049	1	Fianch. Sx (cod.col. E=8D83)	L. side (color code E=8D83)	Flanc G. (code couleur E=8D83)	Wange L.(Cod.Farbe E=8D83)	Lateral iz.(c.color E=8D83)	
	7	80B0 94049	1	Fianch. Sx (cod.col. F=8F03)	L. side (color code F=8F03)	Flanc G. (code couleur F=8F03)	Wange L.(Cod.Farbe F=8F03)	Lateral iz.(c.color F=8F03)	
	8	8000 92330	1	Sottocarena Dx (c.col.B=8E43)	R.underfairing (col.c. B=8E43)	Sous-carène D.(c.col. B=8E43)	R.Unterverk.(cod. Far. B=8E43)	Caren.inf.der.(c.col. B=8E43)	
	8	80A0 94050	1	Sottocarena Dx (c.col.E=8D83)	R.underfairing (col.c. E=8D83)	Sous-carène D.(c.col. E=8D83)	R.Unterverk.(cod. Far. E=8D83)	Caren.inf.der.(c.col. E=8D83)	
	8	80B0 94050	1	Sottocarena Dx (c.col.F=8F03)	R.underfairing (col.c. F=8F03)	Sous-carène D.(c.col. F=8F03)	R.Unterverk.(cod. Far. F=8F03)	Caren.inf.der.(c.col. F=8F03)	
	9	8000 92331	1	Sottocarena Sx (c.col. B=8E43)	L.underfairing (col.c. B=8E43)	Sous-carène G.(c.col. B=8E43)	L.Unterverk.(c. Farbe B=8E43)	Caren.inf.iz.(c.col. B=8E43)	
	9	80A0 94051	1	Sottocarena Sx (c.col. E=8D83)	L.underfairing (col.c. E=8D83)	Sous-carène G.(c.col. E=8D83)	L.Unterverk.(c. Farbe E=8D83)	Caren.inf.iz.(c.col. E=8D83)	
	9	80B0 94051	1	Sottocarena Sx (c.col. F=8F03)	L.underfairing (col.c. F=8F03)	Sous-carène G.(c.col. F=8F03)	L.Unterverk.(c. Farbe F=8F03)	Caren.inf.iz.(c.col. F=8F03)	
	10	8000 A0628	21	Vite	Screw	Vis	Schraube	Tornillo	
	11	7501 0281A	21	Dado	Nut	Ecrou	Mutter	Tuerca	
	12	8000 92324	1	Cupolino (Cod.colore B=8G59)	Fairing (color code B=8G59)	Carenage (cod.coleur B=8G59)	Verkleidung (C.Farbe B=8G59)	Cúpula (código color B=8G59)	
	12	80A0 94054	1	Cupolino (Cod.colore E=8G63)	Fairing (color code E=8G63)	Carenage (cod.coleur E=8G63)	Verkleidung (C.Farbe E=8G63)	Cúpula (código color E=8G63)	
	12	80B0 94054	1	Cupolino (Cod.colore F=8F03)	Fairing (color code F=8F03)	Carenage (cod.coleur F=8F03)	Verkleidung (C.Farbe F=8F03)	Cúpula (código color F=8F03)	
	13	8000 77799	1	Parabrezza	Spoiler	Spoiler	Spoiler	Spoiler	
KZ	13	8000 79677	1	Parabrezza	Spoiler	Spoiler	Spoiler	Spoiler	
	14	8000 77779	1	Piastrina DX	R platte	Plaque D	Platte R	Placa D	
	15	8000 77778	1	Piastrina SX	L platte	Plaque G	Platte L	Placa I	
	16	8000 77902	2	Piastrina inferiore	Platte	Plaque	Platte	Placa	
	17	8000 62726	4	Vite	Screw	Vis	Schraube	Tornillo	
	18	80C0 55698	16	Vite	Screw	Vis	Schraube	Tornillo	
	19	8000 56391	16	Rondella	Washer	Rondelle	Scheibe	Arandela	
	20	8000 48245	16	Dado	Nut	Ecrou	Mutter	Tuerca	
	21	8000 67970	2	Appoggio carena	Support	Support	Halterung	Junta	

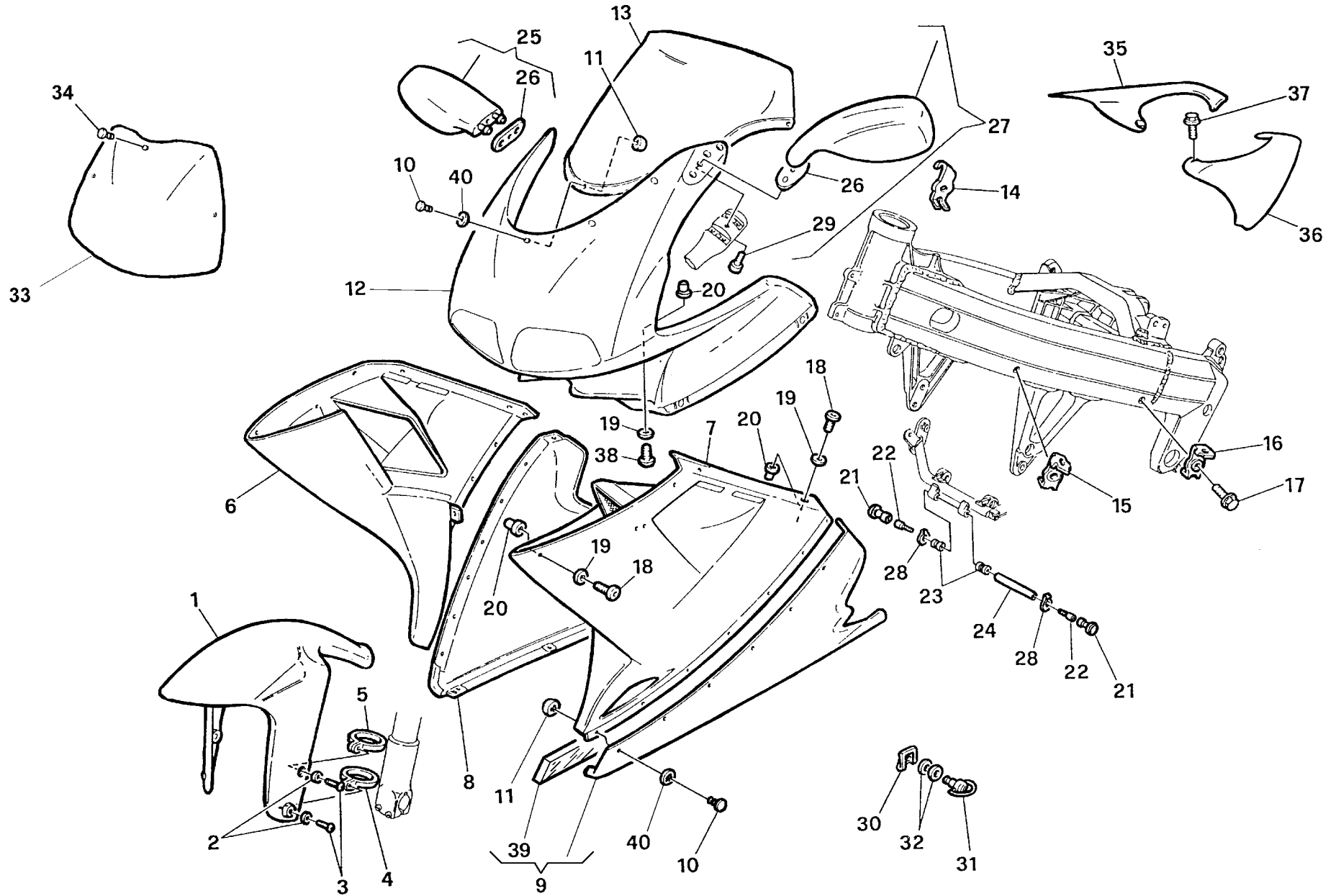



Note Notes Marke Notas	Pos. No. Index Pos.	N. Cod. Code No. Nr. Code Code Nr N. Cod.	Q.tà Q.ty Q.te M.ge C.ad	DENOMINAZIONE	NAME	DESIGNATION	BESHREIBUNG	DENOMINACION	Validità Validity Validité Gültig Valides
	22	8000 67969	2	Registro	Adjustment	Réglage	Regler	Regulación	
	23	8000 62724	2	Appoggio carena	Support	Support	Halterung	Junta	
	24	8A00 67968	1	Asta	Control rood	Coulisseau	Steuerstange	Varilla	
	25	8000 75542	1	Specchietto Dx.	Right mirror	Miroir droit	Rechter Spiegel	Espejo derecho	
	26	8000 62752	2	Guarnizione	Gasket	Garnitue	Dichtung	Junta	
	27	8000 75541	1	Specchietto Sx.	Left mirror	Miroir gauche	Linker Spiegel	Espejo izquierdo	
	28	66N1 21312	2	Anello elastico	Split ring	Anneau resort	Sprengring	Anillo elastico	
	29	8000 77955	2	Vite	Screw	Vis	Schraube	Tornillo	
KZ	30	8504 0191A	13	Attacco rapido	Fast fastener	Ataque rapid	Anschluss	Conexion	
KZ	31	8504 0231A	13	Piolo	Pin	Pivot	Bolzen	Perno	
KZ	32	8504 0081A	26	Rosetta	Washer	Rondelle	Scheibe	Arandelax	
KZ	33	8000 78959	1	Portanumero per cupolino	Transfer	Dècal	Abziehbild	Calcomania	
KZ	34	8000 48966	3	Rivetto	Rivet	Rivet	Niet	Remache	
	35	80B0 78207	1	Paratia Dx (cod. colore B-E-F=8E60)	R guard (colour code B-E-F=8E60)	Protection D (code couleur B-E-F=8E60)	Schutz R (Code Farbe B-E-F=8E60)	Protección d. (còd. colòr B-E-F=8E60)	
	36	80B0 78208	1	Paratia Sx (cod. colore B-E-F=8E60)	L guard (colour code B-E-F=8E60)	Protection G (code couleur B-E-F=8E60)	Schutz L (Code Farbe B-E-F=8E60)	Protección iz. (còd. colòr B-E-F=8E60)	
	37	8D00 90425	2	Vite	Screw	Vis	Schraube	Tornillo	
	38	80B0 55703	2	Vite	Screw	Vis	Schraube	Tornillo	
	39	8000 94067	1	Pannello termoriflettente	Thermal insulation panel	Panneau isolant termique	Wärmeschutzpanel	Panel isoladòr termico	
	40	8000 92882	21	Rondella	Washer	Rondelle	Scheibe	Arandela	
K				A richiesta per kit S.P. '99 cod. 800092789	Upon request for S.P. kit '99 code 800092789	Sur demande pour set S.P. '99 code 800092789	Auf Anfrage für Kit S.P. '99 Code 800092789	Bajo pedido por kit S.P. '99 cod. 800092789	
Z				A richiesta per kit S.P. '01 cod. 800097946	Upon request for S.P. kit '01 code 800097946	Sur demande pour set S.P. '01 code 800092789	Auf Anfrage für Kit S.P. '01 Code 800097946	Bajo pedido por kit S.P. '01 cod. 800097946	

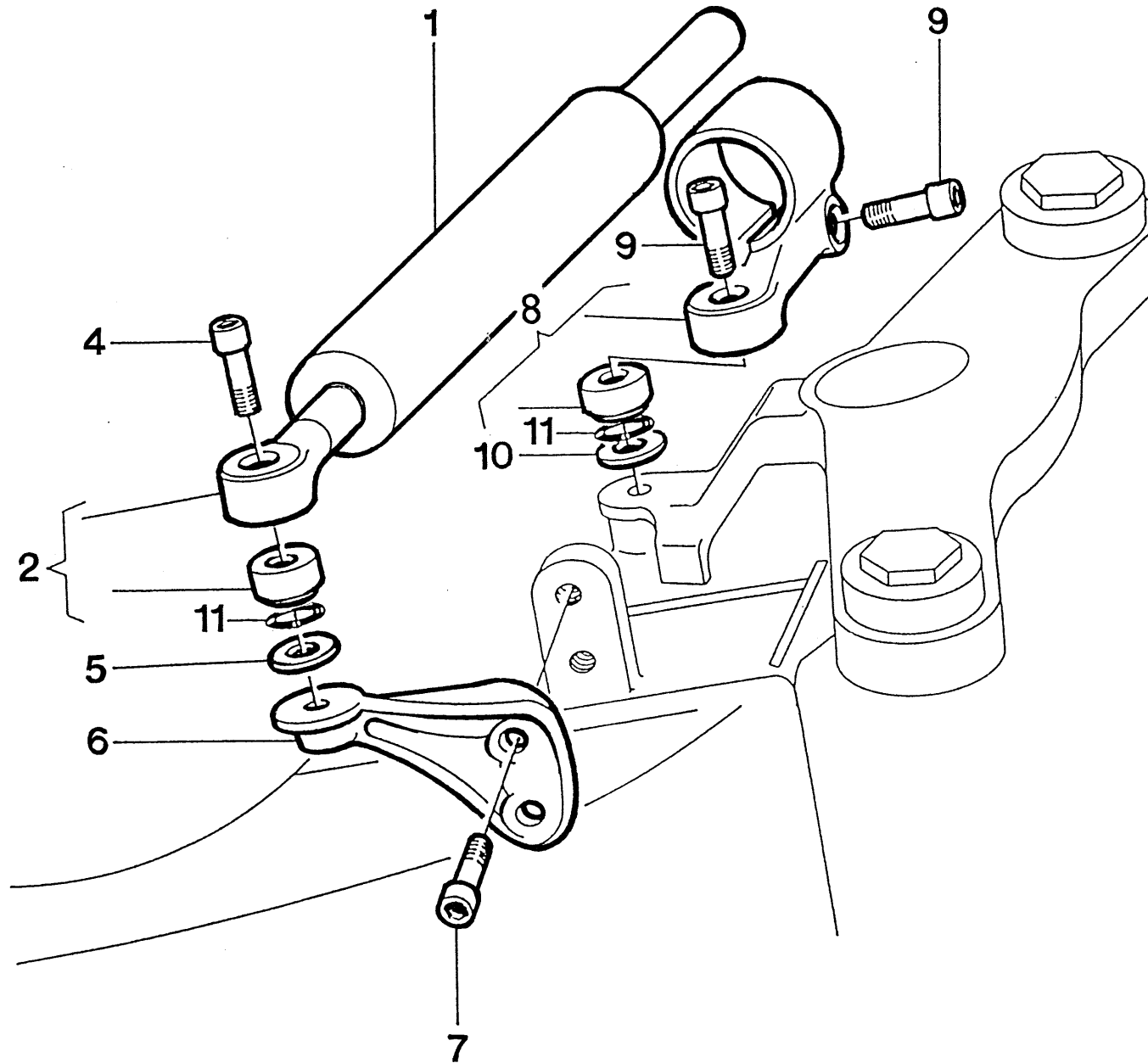



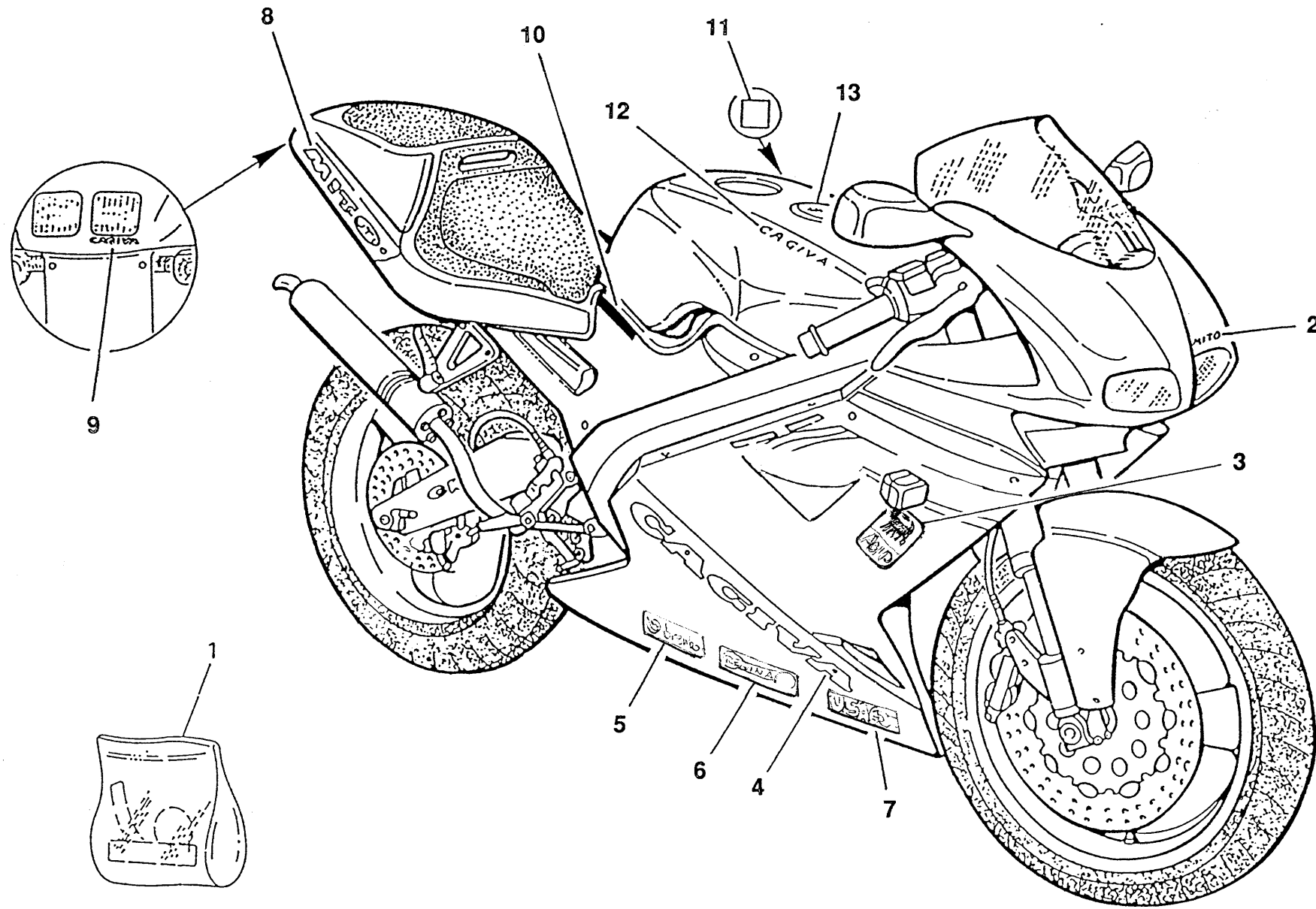

**DECALCOMANIE PER COD. COL. B - F - TRIM COLOR CODE B - F  
 DECALCOMANIES POUR CODE COL. B - F - VERKEIDUNG FUR CODE FARBE B - F  
 CALCOMANIAS PARA COD. COLOR B - F**

Note Notes Marke Notas	Pos. No. Index Pos.	N. Cod. Code No. Nr. Code Code Nr N. Cod.	Q.tà Q.ty Q.te M.ge C.ad	DENOMINAZIONE	NAME	DESIGNATION	BESHREIBUNG	DENOMINACION	Validità Validity Validité Gültig Valides
	1	8000 92337	1	Kit completo codice colore B - F	Kit assy color code B - F	Kit compl. code couleur B - F	Kpl. Kit code Farbe B - F	Juego compl. código col. B - F	
	2	8000 92187	1	Decal MITO	Trim	Décal	Abziehbilder	Calcomanía	
	3	8000 69404	2	Decal AGIP	Trim	Décal	Abziehbilder	Calcomanía	
	4	80A0 92196	2	Decal CAGIVA	Trim	Décal	Abziehbilder	Calcomanía	
	5	8000 74184	2	Decal BREMBO	Trim	Décal	Abziehbilder	Calcomanía	
	6	8000 69396	2	Decal REGINA	Trim	Décal	Abziehbilder	Calcomanía	
	7	8000 72075	2	Decal USAG	Trim	Décal	Abziehbilder	Calcomanía	
	8	80A0 92197	2	Decal MITO	Trim	Décal	Abziehbilder	Calcomanía	
	9	80A0 92198	1	Decal CAGIVA	Trim	Décal	Abziehbilder	Calcomanía	
	10	8000 92199	2	Decal RACING GENERATION	Trim	Décal	Abziehbilder	Calcomanía	
	11	8000 92336	1	Decal choke	Trim	Décal	Abziehbilder	Calcomanía	
	12	80C0 88803	2	Decal CAGIVA	Trim	Décal	Abziehbilder	Calcomanía	
	13	80A0 92187	1	Decal MITO	Trim	Décal	Abziehbilder	Calcomanía	

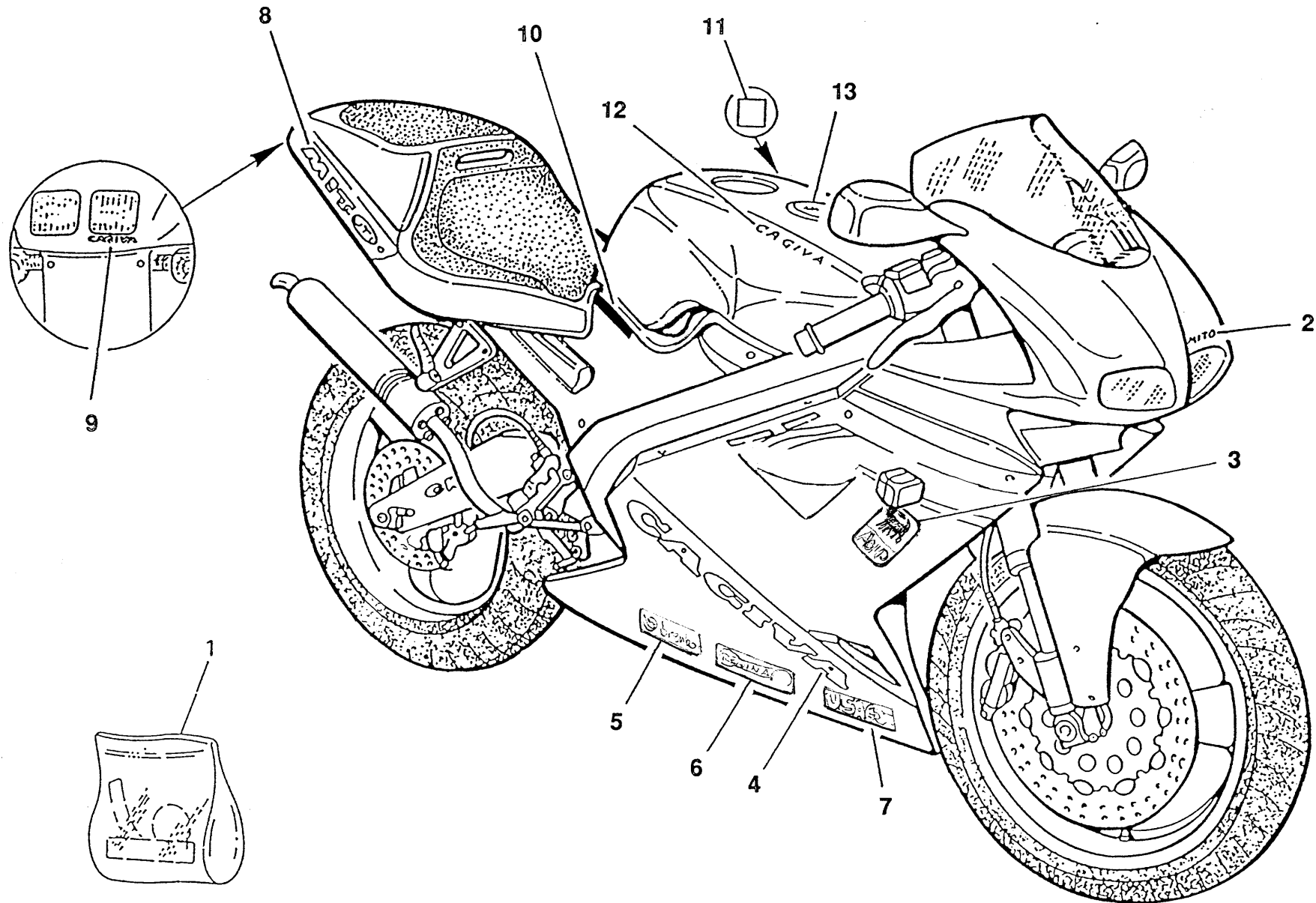

**DECALCOMANIE PER COD. COL. E - TRIM COLOR CODE E**  
**DECALCOMANIES POUR CODE COL. E - VERKEIDUNG FUR CODE FARBE E**  
**CALCOMANIAS PARA COD. COLOR E**

Note Notes Marke Notas	Pos. No. Index Pos.	N. Cod. Code No. Nr. Code Code Nr N. Cod.	Q.tà Q.ty Q.te M.ge C.ad	DENOMINAZIONE	NAME	DESIGNATION	BESHREIBUNG	DENOMINACION	Validità Validity Validité Gültig Valides
	1	8000 94044	1	Kit completo codice colore	Kit assy color code	Kit compl. code couleur	Kpl. Kit code Farbe	Juego compl. código col.	
	2	80A0 92187	1	Decal MITO	Trim	Décal	Abziehbilder	Calcomanía	
	3	8000 69404	2	Decal AGIP	Trim	Décal	Abziehbilder	Calcomanía	
	4	80B0 92196	2	Decal CAGIVA	Trim	Décal	Abziehbilder	Calcomanía	
	5	8000 74184	2	Decal BREMBO	Trim	Décal	Abziehbilder	Calcomanía	
	6	8000 69396	2	Decal REGINA	Trim	Décal	Abziehbilder	Calcomanía	
	7	8000 72075	2	Decal USAG	Trim	Décal	Abziehbilder	Calcomanía	
	8	80A0 92197	2	Decal MITO	Trim	Décal	Abziehbilder	Calcomanía	
	9	80A0 92198	1	Decal CAGIVA	Trim	Décal	Abziehbilder	Calcomanía	
	10	8000 92199	2	Decal RACING GENERATION	Trim	Décal	Abziehbilder	Calcomanía	
	11	8000 92336	1	Decal CHOKE	Trim	Décal	Abziehbilder	Calcomanía	
	12	80D0 88803	2	Decal CAGIVA	Trim	Décal	Abziehbilder	Calcomanía	
	13	80A0 92187	1	Decal MITO	Trim	Décal	Abziehbilder	Calcomanía	

DISEGNO DRAWING DESSIN ZEICHNUNG DIBUJO	TAVOLA DRAWING TABLE BILD TABLA	POS. NO. N. IND. POS.	DISEGNO DRAWING DESSIN ZEICHNUNG DIBUJO	TAVOLA DRAWING TABLE BILD TABLA	POS. NO. N. IND. POS.	DISEGNO DRAWING DESSIN ZEICHNUNG DIBUJO	TAVOLA DRAWING TABLE BILD TABLA	POS. NO. N. IND. POS.	DISEGNO DRAWING DESSIN ZEICHNUNG DIBUJO	TAVOLA DRAWING TABLE BILD TABLA	POS. NO. N. IND. POS.	DISEGNO DRAWING DESSIN ZEICHNUNG DIBUJO	TAVOLA DRAWING TABLE BILD TABLA	POS. NO. N. IND. POS.
000Y A2271	1	9	60N1 07335	4	20	66N0 21202	4	24	8000 04898	25	10	8000 21840	25	19
0370 72020	13	9	60N1 07335	6	22	66N0 21203	9	25	8000 04898	27	32	8000 21929	2	6
0370 72020	21	17	60N1 07335	11	4	66N0 21204	8	42	8000 04898	30	30	8000 22271	15	42
3644 0031A	32	1	60N1 07335	11A	11	66N0 21204	11B	14	8000 05272	8	21	8000 22375	11B	4
3974 0011A	28	39	60N1 07351	22	9	66N0 21206	11B	11	8000 05893	14	30	8000 22672	14	2
5164 0011A	27	13	60N1 07351	22	32	66N0 21209	8	39	8000 07051	15	6	8000 22946	5	22
5394 0031B	22	15	60N1 07701	21	7	66N0 21275	24	13	8000 07719	5	12	8000 23106	32	11
60N1 01050	3	11	60N1 15766	3	12	66N1 21303	19	13	8000 07989	8	19	8000 23118	10	22
60N1 01078	5	10	60N2 21208	8	5	66N1 21307	25	27	8000 09721	20	18	8000 23981	12	14
60N1 01081	11B	18	61N1 15001	21	8	66N1 21308	14	13	8000 11276	2	27	8000 23983	12	40
60N1 01081	15	41	61N1 15031	15	33	66N1 21308	15	21	8000 11868	7	3	8000 24078	24	25
60N1 01082	2	22	61N1 15062	9	35	66N1 21309	20	17	8000 12029	12	42	8000 24839	9	13
60N1 01140	8	24	61N1 15062	22	3	66N1 21312	31	28	8000 12030	12	41	8000 24840	9	7
60N1 01878	5	39	61N1 15062	22	10	6BN0 21505	9	6	8000 12037	12	44	8000 24841	9	8
60N1 02482	28	18	61N1 15062	28	25	6BN0 21507	15	19	8000 12045	12	31	8000 24856	9	45
60N1 02483	5	15	61N1 15151	3	30	7001 0201A	27	3	8000 12634	11	18	8000 24857	9	3
60N1 02489	3	28	61N1 15503	15	40	7411 0151A	21	24	8000 15397	16	27	8000 24905	11B	6
60N1 02509	11	20	62N0 15599	6	16	7411 0151A	22	23	8000 15659	24	5	8000 24947	5	24
60N1 02509	11A	4	62N0 15676	2	12	7415 0111B	4	14	8000 15960	6	23	8000 24962	6	13
60N1 02509	15	36	62N1 15503	3	22	7415 0211B	4	37	8000 17810	2	28	8000 24962	10	12
60N1 02510	6	11	62N1 15506	22	34	7415 0231B	4	29	8000 18246	30	23	8000 25044	7	10
60N1 02511	6	24	62N1 15536	11	28	7415 0251B	4	28	8000 19069	10	9	8000 25151	8	4
60N1 02512	6	14	62N1 15547	30	47	7415 0261B	4	13	8000 19070	10	10	8000 25254	9	23
60N1 02512	6	19	62N1 15549	28	61	7415 0441B	2	37	8000 19071	10	11	8000 26134	9	14
60N1 02515	5	23	62N1 15765	15	32	7501 0281A	31	11	8000 19604	9	24	8000 26884	10	5
60N1 02515	6	27	62N1 15766	11	18	7791 0921A	21	20	8000 19620	5	35	8000 27073	26	13
60N1 02515	30	29	62N1 15766	11A	24	7991 0641A	27	10	8000 19789	8	27	8000 27103	9	2
60N1 02516	5	19	62N1 15767	28	26	8000 01025	7	20	8000 20474	11B	17	8000 27103	9	43
60N1 02518	20	9	63N0 16349	7	25	8000 01199	9	30	8000 20602	29	10	8000 27960	6	8
60N1 02901	11	19	6562 0121A	20	23	8000 01199	22	6	8000 21198	20	13	8000 30319	4	32
60N1 02901	11A	25	6584 0021A	20	5	8000 04104	12	17	8000 21375	9	5	8000 30728	5	7
60N1 03834	9	9	65N0 21002	11	15	8000 04898	4	10	8000 21375	9	46	8000 30820	7	19
60N1 07330	3	15	65N0 21002	11A	23	8000 04898	15	3	8000 21480	21	12	8000 30856	2	21
60N1 07330	25	1	65N0 21007	7	4	8000 04898	15	42	8000 21810	12	49	8000 30860	5	4



DISEGNO DRAWING DESSIN ZEICHNUNG DIBUJO	TAVOLA DRAWING TABLE BILD TABLA	POS. NO. N. IND. POS.	DISEGNO DRAWING DESSIN ZEICHNUNG DIBUJO	TAVOLA DRAWING TABLE BILD TABLA	POS. NO. N. IND. POS.	DISEGNO DRAWING DESSIN ZEICHNUNG DIBUJO	TAVOLA DRAWING TABLE BILD TABLA	POS. NO. N. IND. POS.	DISEGNO DRAWING DESSIN ZEICHNUNG DIBUJO	TAVOLA DRAWING TABLE BILD TABLA	POS. NO. N. IND. POS.	DISEGNO DRAWING DESSIN ZEICHNUNG DIBUJO	TAVOLA DRAWING TABLE BILD TABLA	POS. NO. N. IND. POS.
8000 31378	7	12	8000 35086	12	27	8000 40718	15	39	8000 44240	26	4	8000 47674	11	27
8000 31695	11B	15	8000 35119	9	15	8000 41039	30	14	8000 44240	27	33	8000 47675	11	9
8000 31696	11B	16	8000 35353	12	29	8000 41460	23	10	8000 44240	28	46	8000 47676	11	8
8000 31739	7	6	8000 36230	27	23	8000 41862	27	21	8000 44240	28	62	8000 47677	11	22
8000 31748	3	25	8000 36357	5	21	8000 42022	18	9	8000 44240	30	31	8000 47678	5	8
8000 31762	11B	7	8000 36379	11B	1	8000 42023	11	13	8000 44240	30	44	8000 47678	5	29
8000 31763	11B	8	8000 36380	3	23	8000 42023	11A	21	8000 44299	9	19	8000 47679	11	26
8000 31764	11B	10	8000 36440	5	30	8000 42164	5	11	8000 44300	9	12	8000 47701	4	18
8000 31768	8	30	8000 36653	6	30	8000 42259	4	23	8000 44346	7	15	8000 47707	2	18
8000 31768	8	31	8000 36682	12	28	8000 42274	28	35	8000 46147	22	30	8000 47708	5	3
8000 31773	8	9	8000 36685	12	15	8000 42278	3	17	8000 46393	5	38	8000 47716	3	32
8000 31813	7	11	8000 36687	12	23	8000 42278	4	26	8000 46428	7	8	8000 47719	7	2
8000 32064	17	2	8000 36726	27	29	8000 42278	29	2	8000 46487	26	12	8000 47953	21	6
8000 32065	17	3	8000 36726	30	27	8000 42282	11B	13	8000 46532	8	6	8000 48245	30	4
8000 32231	2	7	8000 37198	5	25	8000 42284	11B	3	8000 46533	8	28	8000 48245	30	8
8000 32389	5	20	8000 37343	2	5	8000 42285	4	22	8000 46534	8	13	8000 48245	31	20
8000 32855	12	18	8000 37977	16	14	8000 42288	7	9	8000 46592	2	24	8000 48381	2	4
8000 33047	1	2	8000 38078	6	25	8000 42345	21	4	8000 46613	1	1	8000 48412	25	37
8000 33048	1	3	8000 38203	2	17	8000 42676	9	18	8000 46614	1	5	8000 48432	22	33
8000 33054	1	6	8000 38210	8	33	8000 42677	9	17	8000 46664	21	3	8000 48801	4	35
8000 33109	12	8	8000 38707	7	24	8000 42700	9	21	8000 47373	11	6	8000 48803	1	8
8000 33270	10	6	8000 38726	7	17	8000 43199	8	18	8000 47374	11	1	8000 48848	5	40
8000 33272	10	15	8000 38727	7	16	8000 43199	8	32	8000 47374	11A	18	8000 48852	7	21
8000 33273	10	16	8000 38956	18	2	8000 43382	5	31	8000 47375	6	21	8000 48853	7	23
8000 33377	27	20	8000 38957	18	3	8000 43823	1	4	8000 47381	11	12	8000 48855	7	22
8000 33642	5	2	8000 38957	18	11	8000 43859	9	11	8000 47381	11A	9	8000 48856	6	4
8000 33718	5	32	8000 39260	3	7	8000 43928	14	6	8000 47456	24	25	8000 48861	5	14
8000 33721	9	20	8000 39335	2	13	8000 43928	14	26	8000 47456	24	25	8000 48862	5	16
8000 34035	9	10	8000 39726	22	29	8000 43928	15	23	8000 47467	28	54	8000 48864	6	20
8000 34323	6	3	8000 39727	22	28	8000 43928	15	26	8000 47472	28	5	8000 48865	6	6
8000 34323	18	20	8000 40220	7	15	8000 44043	12	21	8000 47667	10	4	8000 48874	7	14
8000 34358	2	3	8000 40427	4	34	8000 44240	9	40	8000 47670	11	23	8000 48875	7	18
8000 34690	8	14	8000 40580	12	22	8000 44240	15	4	8000 47672	11	25	8000 48878	11	2
8000 34924	26	14	8000 40582	12	19	8000 44240	22	18	8000 47673	11	30	8000 48878	11A	20

DISEGNO DRAWING DESSIN ZEICHNUNG DIBUJO	TAVOLA DRAWING TABLE BILD TABLA	POS. NO. N. IND. POS.	DISEGNO DRAWING DESSIN ZEICHNUNG DIBUJO	TAVOLA DRAWING TABLE BILD TABLA	POS. NO. N. IND. POS.	DISEGNO DRAWING DESSIN ZEICHNUNG DIBUJO	TAVOLA DRAWING TABLE BILD TABLA	POS. NO. N. IND. POS.	DISEGNO DRAWING DESSIN ZEICHNUNG DIBUJO	TAVOLA DRAWING TABLE BILD TABLA	POS. NO. N. IND. POS.	DISEGNO DRAWING DESSIN ZEICHNUNG DIBUJO	TAVOLA DRAWING TABLE BILD TABLA	POS. NO. N. IND. POS.
8000 48966	31	34	8000 53130	8	7	8000 56722	10	23	8000 59485	9	29	8000 62586	22	7
8000 48971	13	10	8000 53185	24	7	8000 56741	29	13	8000 59485	22	5	8000 62587	23	9
8000 49016	5	9	8000 53248	5	6	8000 56742	29	5	8000 59980	4	21	8000 62592	14	20
8000 49016	6	5	8000 53248	5	17	8000 56746	29	9	8000 60033	27	8	8000 62595	14	25
8000 49531	12	46	8000 53249	2	15	8000 56747	29	8	8000 60404	21	28	8000 62608	24	14
8000 49557	2	26	8000 53259	21	32	8000 56748	29	7	8000 60415	4	25	8000 62609	24	9
8000 49628	11	3	8000 53339	5	26	8000 56750	29	4	8000 60430	3	26	8000 62609	24	9
8000 49628	11A	19	8000 53392	8	8	8000 56752	29	25	8000 60683	14	17	8000 62612	24	17
8000 49642	10	17	8000 53554	14	3	8000 56770	8	41	8000 60684	9	36	8000 62613	24	18
8000 49767	1	7	8000 53717	10	20	8000 56783	27	25	8000 60686	9	31	8000 62615	24	6
8000 49778	8	22	8000 53724	28	23	8000 57006	17	15	8000 60693	14	19	8000 62622	17	13
8000 49887	28	4	8000 54695	8	16	8000 57155	21	11	8000 60700	14	11	8000 62636	9	27
8000 49917	3	29	8000 54696	3	21	8000 57165	2	23	8000 61070	9	38	8000 62636	22	11
8000 50042	11	31	8000 54874	8	20	8000 57182	5	36	8000 61070	9	39	8000 62637	17	7
8000 50043	11	10	8000 54882	2	9	8000 57185	6	7	8000 61102	2	30	8000 62638	17	8
8000 50044	11	11	8000 54884	2	8	8000 57196	5	33	8000 61260	9	41	8000 62639	17	9
8000 50044	11A	12	8000 54893	3	18	8000 57436	12	32	8000 61261	8	38	8000 62644	14	22
8000 50045	11	5	8000 54894	3	14	8000 57437	12	34	8000 62154	8	25	8000 62645	28	30
8000 50045	11A	13	8000 54896	3	16	8000 57536	4	19	8000 62195	9	1	8000 62646	14	27
8000 50251	11	29	8000 55520	16	13	8000 57660	11B	9	8000 62200	5	27	8000 62648	23	6
8000 51521	1	11	8000 55587	7	26	8000 57757	22	14	8000 62210	9	4	8000 62651	4	6
8000 51549	5	18	8000 55588	7	27	8000 57758	22	13	8000 62341	26	14	8000 62651	4	9
8000 51614	1	1	8000 55703	30	17	8000 57772	21	31	8000 62390	3	6	8000 62651	26	7
8000 51660	10	3	8000 55991	22	12	8000 58046	3	31	8000 62561	17	16	8000 62651	30	25
8000 51662	10	2	8000 56006	6	2	8000 58048	3	20	8000 62567	14	18	8000 62652	4	7
8000 51726	11	24	8000 56391	17	12	8000 58140	15	12	8000 62568	14	16	8000 62652	26	8
8000 51971	5	5	8000 56391	30	3	8000 58806	28	59	8000 62569	18	17	8000 62653	17	14
8000 51987	12	12	8000 56391	31	2	8000 58861	3	27	8000 62570	18	12	8000 62654	17	10
8000 52129	10	7	8000 56391	31	19	8000 58865	3	19	8000 62571	18	7	8000 62669	17	4
8000 52232	6	31	8000 56410	24	11	8000 59030	11	17	8000 62572	18	14	8000 62675	14	23
8000 52292	6	29	8000 56443	28	33	8000 59030	11A	15	8000 62573	18	16	8000 62676	14	24
8000 52447	8	3	8000 56444	28	7	8000 59034	3	1	8000 62574	18	8	8000 62677	28	27
8000 52448	8	15	8000 56459	9	34	8000 59287	3	5	8000 62575	18	13	8000 62700	15	7
8000 52662	21	2	8000 56465	29	6	8000 59394	28	34	8000 62576	24	22	8000 62703	4	3

DISEGNO DRAWING DESSIN ZEICHNUNG DIBUJO	TAVOLA DRAWING TABLE BILD TABLA	POS. NO. N. IND. POS.	DISEGNO DRAWING DESSIN ZEICHNUNG DIBUJO	TAVOLA DRAWING TABLE BILD TABLA	POS. NO. N. IND. POS.	DISEGNO DRAWING DESSIN ZEICHNUNG DIBUJO	TAVOLA DRAWING TABLE BILD TABLA	POS. NO. N. IND. POS.	DISEGNO DRAWING DESSIN ZEICHNUNG DIBUJO	TAVOLA DRAWING TABLE BILD TABLA	POS. NO. N. IND. POS.	DISEGNO DRAWING DESSIN ZEICHNUNG DIBUJO	TAVOLA DRAWING TABLE BILD TABLA	POS. NO. N. IND. POS.
8000 62705	3	8	8000 62730	26	9	8000 66308	15	8	8000 67957	5	41	8000 70160	25	15
8000 62705	4	5	8000 62731	29	21	8000 66312	15	27	8000 67963	25	36	8000 70163	19	27
8000 62705	4	11	8000 62732	24	10	8000 66313	15	28	8000 67969	31	22	8000 70163	32	5
8000 62705	25	7	8000 62743	28	58	8000 66336	27	19	8000 67970	31	21	8000 70165	25	14
8000 62717	4	17	8000 62751	25	30	8000 66339	28	15	8000 67977	17	18	8000 70167	23	11
8000 62720	4	12	8000 62752	31	26	8000 66340	28	16	8000 67978	14	34	8000 70172	29	22
8000 62721	4	15	8000 62796	2	11	8000 66362	25	4	8000 67981	22	2	8000 70173	21	13
8000 62724	31	23	8000 64169	12	38	8000 66363	25	11	8000 67987	14	5	8000 70178	25	28
8000 62725	3	9	8000 64170	12	47	8000 66366	29	18	8000 68003	8	22	8000 70181	16	5
8000 62725	14	28	8000 64296	3	24	8000 66503	22	27	8000 68017	24	24	8000 70182	16	4
8000 62725	15	11	8000 64471	23	7	8000 66506	13	1	8000 68490	21	15	8000 70185	20	16
8000 62725	17	17	8000 64586	10	14	8000 66507	13	2	8000 68543	1	14	8000 70186	19	23
8000 62725	21	16	8000 64833	7	1	8000 66510	13	6	8000 68873	10	13	8000 70569	1	12
8000 62725	21	22	8000 65302	2	38	8000 66525	28	13	8000 69069	30	49	8000 70582	1	10
8000 62725	22	21	8000 65318	29	11	8000 66529	22	19	8000 69171	2	31	8000 70966	16	16
8000 62725	25	9	8000 65575	11	32	8000 66550	11	33	8000 69172	2	33	8000 71414	10	24
8000 62725	28	10	8000 66155	15	9	8000 66550	11A	16	8000 69247	8	1	8000 71487	19	9
8000 62725	28	29	8000 66156	30	15	8000 66565	11	14	8000 69248	8	2	8000 71488	19	3
8000 62725	28	44	8000 66157	25	2	8000 66565	11A	22	8000 69249	8	12	8000 71489	19	25
8000 62726	4	33	8000 66159	28	19	8000 66774	20	11	8000 69250	8	17	8000 71764	10	8
8000 62726	25	20	8000 66163	20	7	8000 66803	28	42	8000 69251	8	29	8000 72075	33	7
8000 62726	28	36	8000 66164	20	8	8000 67143	4	8	8000 69252	8	10	8000 72075	33A	7
8000 62726	30	6	8000 66174	9	26	8000 67161	21	9	8000 69253	9	16	8000 72168	18	4
8000 62726	31	17	8000 66177	22	1	8000 67165	18	5	8000 69273	8	11	8000 72168	18	18
8000 62727	15	2	8000 66180	22	24	8000 67171	13	7	8000 69396	33	6	8000 72169	18	19
8000 62727	15	41	8000 66181	21	14	8000 67501	2	16	8000 69396	33A	6	8000 72228	23	5
8000 62727	25	26	8000 66188	17	5	8000 67548	28	22	8000 69404	33	3	8000 72234	21	10
8000 62727	27	15	8000 66190	18	10	8000 67548	28	38	8000 69404	33A	3	8000 72633	2	36
8000 62727	28	40	8000 66204	3	13	8000 67576	2	32	8000 70115	23	12	8000 72887	28	47
8000 62727	28	60	8000 66292	17	21	8000 67943	3	4	8000 70119	23	13	8000 72911	30	33
8000 62728	13	5	8000 66293	17	20	8000 67948	28	32	8000 70130	29	24	8000 72912	30	34
8000 62728	20	6	8000 66298	15	30	8000 67949	28	31	8000 70140	16	1	8000 73030	14	31
8000 62729	2	22	8000 66304	22	26	8000 67953	25	6	8000 70152	32	6	8000 73031	14	32
8000 62729	26	15	8000 66305	22	20	8000 67953	26	5	8000 70158	25	38	8000 73049	5	36

DISEGNO DRAWING DESSIN ZEICHNUNG DIBUJO	TAVOLA DRAWING TABLE BILD TABLA	POS. NO. N. IND. POS.	DISEGNO DRAWING DESSIN ZEICHNUNG DIBUJO	TAVOLA DRAWING TABLE BILD TABLA	POS. NO. N. IND. POS.	DISEGNO DRAWING DESSIN ZEICHNUNG DIBUJO	TAVOLA DRAWING TABLE BILD TABLA	POS. NO. N. IND. POS.	DISEGNO DRAWING DESSIN ZEICHNUNG DIBUJO	TAVOLA DRAWING TABLE BILD TABLA	POS. NO. N. IND. POS.	DISEGNO DRAWING DESSIN ZEICHNUNG DIBUJO	TAVOLA DRAWING TABLE BILD TABLA	POS. NO. N. IND. POS.
8000 73088	17	22	8000 77756	30	5	8000 77922	25	22	8000 78201	25	5	8000 79680	27	2
8000 73111	4	39	8000 77770	28	20	8000 77923	25	29	8000 78202	25	31	8000 79889	16	7
8000 73113	27	24	8000 77771	15	10	8000 77927	30	11	8000 78206	29	26	8000 79891	16	23
8000 73115	4	38	8000 77772	27	16	8000 77934	29	18	8000 78210	30	46	8000 79894	16	11
8000 73530	30	19	8000 77773	27	17	8000 77935	29	17	8000 78212	30	45	8000 79936	12	26
8000 73649	8	25	8000 77776	19	1	8000 77936	29	16	8000 78213	28	11	8000 79939	24	25
8000 73650	8	23	8000 77777	19	16	8000 77937	29	19	8000 78331	21	27	8000 80301	21	29
8000 73834	15	31	8000 77778	31	15	8000 77938	29	3	8000 78332	25	21	8000 80453	29	28
8000 74184	33	5	8000 77779	31	14	8000 77939	19	8	8000 78335	26	2	8000 81785	2	14
8000 74184	33A	5	8000 77781	21	25	8000 77940	19	2	8000 78336	29	23	8000 81941	25	39
8000 74190	27	6	8000 77782	21	30	8000 77941	19	6	8000 78337	27	27	8000 81984	2	5
8000 74287	20	19	8000 77783	21	26	8000 77942	19	15	8000 78338	27	30	8000 82864	7	13
8000 74507	27	28	8000 77784	19	18	8000 77943	19	12	8000 78339	30	32	8000 85791	11	34
8000 74507	30	28	8000 77787	20	3	8000 77944	19	4	8000 78340	30	26	8000 85907	23	4
8000 75270	28	51	8000 77788	20	4	8000 77945	19	7	8000 78342	27	22	8000 85969	11	17
8000 75398	11A	1	8000 77789	19	28	8000 77946	19	5	8000 78346	27	14	8000 85972	26	1
8000 75399	11A	2	8000 77790	19	26	8000 77947	20	12	8000 78347	29	12	8000 86750	28	57
8000 75400	11A	3	8000 77791	19	24	8000 77949	20	15	8000 78348	29	15	8000 86751	28	56
8000 75402	11A	5	8000 77792	16	3	8000 77950	20	14	8000 78350	28	9	8000 86751	28	56
8000 75403	11A	6	8000 77795	17	19	8000 77954	32	8	8000 78656	25	40	8000 87038	16	15
8000 75404	11A	7	8000 77799	31	13	8000 77955	31	29	8000 78714	11B	19	8000 87150	12	54
8000 75405	11A	10	8000 77809	15	1	8000 77962	21	1	8000 78890	16	28	8000 87563	12	11
8000 75407	11A	8	8000 77891	15	5	8000 77966	26	11	8000 78959	31	33	8000 87573	24	16
8000 75541	31	27	8000 77894	28	1	8000 77967	30	42	8000 79006	16	18	8000 87578	24	26
8000 75542	31	25	8000 77898	30	24	8000 77969	30	22	8000 79007	16	9	8000 87696	15	37
8000 76055	9	32	8000 77899	27	2	8000 78174	28	28	8000 79008	16	26	8000 87741	23	1
8000 76785	18	6	8000 77900	19	17	8000 78176	30	9	8000 79039	27	26	8000 87742	24	1
8000 76984	3	35	8000 77901	20	10	8000 78177	30	12	8000 79040	26	21	8000 88173	28	21
8000 77030	18	1	8000 77902	31	16	8000 78178	30	18	8000 79146	4	36	8000 88306	17	10
8000 77360	16	8	8000 77903	30	21	8000 78179	3	36	8000 79672	27	4	8000 88306	17	10
8000 77378	16	12	8000 77905	25	34	8000 78180	28	8	8000 79673	27	7	8000 88759	28	50
8000 77752	14	1	8000 77907	25	12	8000 78181	14	33	8000 79674	27	5	8000 89038	28	55
8000 77754	15	24	8000 77920	25	32	8000 78182	20	20	8000 79677	31	13	8000 89846	28	37
8000 77755	25	17	8000 77921	25	18	8000 78184	26	10	8000 79680	27	2	8000 90012	28	63

DISEGNO DRAWING DESSIN ZEICHNUNG DIBUJO	TAVOLA DRAWING TABLE BILD TABLA	POS. NO. N. IND. POS.	DISEGNO DRAWING DESSIN ZEICHNUNG DIBUJO	TAVOLA DRAWING TABLE BILD TABLA	POS. NO. N. IND. POS.	DISEGNO DRAWING DESSIN ZEICHNUNG DIBUJO	TAVOLA DRAWING TABLE BILD TABLA	POS. NO. N. IND. POS.	DISEGNO DRAWING DESSIN ZEICHNUNG DIBUJO	TAVOLA DRAWING TABLE BILD TABLA	POS. NO. N. IND. POS.	DISEGNO DRAWING DESSIN ZEICHNUNG DIBUJO	TAVOLA DRAWING TABLE BILD TABLA	POS. NO. N. IND. POS.
8000 90202	2	25	8000 92337	33	1	8000 98349	5	13	80A0 60689	24	20	80B0 78016	24	8
8000 90203	2	21	8000 92387	15	35	8000 98431	1	15	80A0 60690	24	21	80B0 78207	31	35
8000 90206	2	1	8000 92388	15	34	8000 99015	26	1	80A0 60697	22	31	80B0 78208	31	36
8000 90499	13	3	8000 92402	28	35	8000 99017	26	2	80A0 62649	26	6	80B0 92196	33A	4
8000 90500	1	13	8000 92404	28	34	8000 99355	5	1	80A0 62672	25	8	80B0 94047	25	3
8000 90502	26	11	8000 92882	31	40	8000 99676	28	14	80A0 63846	12	53	80B0 94048	31	6
8000 90582	28	53	8000 93045	1	14	8000 A0070	15	17	80A0 64818	2	14	80B0 94049	31	7
8000 90835	23	3	8000 93061	28	57	8000 A0204	15	18	80A0 66501	4	1	80B0 94050	31	8
8000 90877	28	51	8000 93969	13	4	8000 A0400	2	1	80A0 66845	6	12	80B0 94051	31	9
8000 91794	24	3	8000 93969	13	4	8000 A0402	2	2	80A0 67502	24	23	80B0 94053	30	16
8000 91796	23	2	8000 94044	33A	1	8000 A0402	2	2	80A0 70175	25	25	80B0 94054	31	12
8000 91796	24	2	8000 94067	31	39	8000 A0402	2	2	80A0 70179	15	15	80C0 35357	12	9
8000 91813	12	36	8000 94105	2	6	8000 A0512	27	13	80A0 70180	15	13	80C0 36681	12	1
8000 91875	28	50	8000 94147	26	23	8000 A0554	12	55	80A0 88204	6	26	80C0 55698	30	2
8000 91877	2	4	8000 94346	29	14	8000 A0628	31	10	80A0 92187	33	13	80C0 55698	31	3
8000 92027	10	1	8000 94595	15	7	8000 A0632	18	15	80A0 92187	33A	2	80C0 55698	31	18
8000 92187	33	2	8000 94600	28	6	8000 A0807	16	17	80A0 92187	33A	13	80C0 62650	17	1
8000 92199	33	10	8000 94671	26	17	8000 A0937	16	10	80A0 92196	33	4	80C0 66843	6	1
8000 92199	33A	10	8000 96516	28	64	8000 A0940	16	6	80A0 92197	33	8	80C0 77951	30	41
8000 92229	13	4	8000 96883	26	1	8000 A0941	16	25	80A0 92197	33A	8	80C0 88803	33	12
8000 92242	2	29	8000 96884	2	14	8000 A1007	21	21	80A0 92198	33	9	80D0 36681	12	1
8000 92243	2	6	8000 96963/1	2	2	8000 A1045	26	1	80A0 92198	33A	9	80D0 63846	12	53
8000 92313	28	45	8000 96963/2	2	2	8000 A1055	2	19	80A0 94047	25	3	80D0 63846	12	53
8000 92324	31	12	8000 96963/3	2	2	8000 A1062	12	36	80A0 94048	31	6	80D0 88803	33A	12
8000 92325	25	3	8000 97295	28	51	80A0 19963	24	19	80A0 94049	31	7	80E0 12041	12	4
8000 92328	31	6	8000 97583	2	39	80A0 31817	6	15	80A0 94050	31	8	80E0 12041	12	4
8000 92329	31	7	8000 97584	2	9	80A0 47665	7	5	80A0 94051	31	9	80F0 12032	12	7
8000 92330	31	8	8000 97585	2	29	80A0 47665	7	7	80A0 94053	30	16	80F0 70166	31	1
8000 92331	31	9	8000 97725	28	34	80A0 53546	14	12	80A0 94054	31	12	80F0 77951	30	41
8000 92332	30	7	8000 97741	2	1	80A0 53546	15	20	80B0 55703	17	11	80G0 12041	12	4
8000 92333	30	1	8000 97949	2	21	80A0 53548	9	28	80B0 55703	31	38	80H0 12041	12	4
8000 92335	30	16	8000 97950	2	25	80A0 53548	22	4	80B0 66847	6	28	80H0 77951	30	41
8000 92336	33	11	8000 98016	22	16	80A0 55757	22	8	80B0 70127	31	5	80I0 12041	12	4
8000 92336	33A	11	8000 98213	2	35	80A0 60688	14	14	80B0 70133	31	4	80N0 12041	12	4

DISEGNO DRAWING DESSIN ZEICHNUNG DIBUJO	TAVOLA DRAWING TABLE BILD TABLA	POS. NO. N. IND. POS.	DISEGNO DRAWING DESSIN ZEICHNUNG DIBUJO	TAVOLA DRAWING TABLE BILD TABLA	POS. NO. N. IND. POS.	DISEGNO DRAWING DESSIN ZEICHNUNG DIBUJO	TAVOLA DRAWING TABLE BILD TABLA	POS. NO. N. IND. POS.	DISEGNO DRAWING DESSIN ZEICHNUNG DIBUJO	TAVOLA DRAWING TABLE BILD TABLA	POS. NO. N. IND. POS.	DISEGNO DRAWING DESSIN ZEICHNUNG DIBUJO	TAVOLA DRAWING TABLE BILD TABLA	POS. NO. N. IND. POS.
80N0 12041	12	4	8A00 66293	17	20	8B00 41750	5	34	8C00 90424	26	20	8E00 90426	14	8
80S0 36683	12	2	8A00 66492	29	29	8B00 49557	2	26	8D00 04553	8	40	8E00 90426	14	21
82911121AB	29	1	8A00 67174	26	3	8B00 51600	30	48	8D00 04553	11B	5	8E00 90426	15	22
8292 0841A	21	19	8A00 67545	26	16	8B00 66536	28	17	8D00 10350	2	10	8F00 11868	7	3
8482 0011A	32	2	8A00 67545	26	22	8B00 67576	2	32	8D00 11868	7	3	8F00 32069	17	6
8504 0081A	31	32	8A00 67781	3	10	8B00 68003	8	22	8D00 32069	17	6	8F00 38210	8	33
8504 0191A	31	30	8A00 67968	31	24	8B00 70163	19	27	8D00 33690	15	29	8F00 49525	12	3
8504 0231A	31	31	8A00 68003	8	22	8B00 73093	24	9	8D00 38210	8	33	8F00 62609	24	9
8521 0501A	32	10	8A00 68666	4	31	8B00 73541	26	13	8D00 49525	12	3	8F00 67963	25	33
8661 0191A	30	35	8A00 69056	16	22	8B00 77929	30	13	8D00 49525	12	3	8G00 04551	11B	2
8931 0041A	4	2	8A00 70163	19	27	8B00 79938	24	24	8D00 49557	2	26	8G00 05272	8	21
8A00 09408	9	44	8A00 71276	30	43	8B00 87148	12	6	8D00 55507	12	50	8G00 07989	8	19
8A00 10350	2	10	8A00 73093	24	9	8BA0 37390	28	48	8D00 60831	24	24	8G00 10904	11B	12
8A00 11868	7	3	8A00 76055	9	33	8BA0 67545	30	10	8D00 67545	29	20	8G00 11868	7	3
8A00 23186	26	12	8A00 77895	28	2	8BE0 12041	12	4	8D00 70163	19	27	8G00 31756	11	7
8A00 24841	9	8	8A00 77910	10	19	8C00 05272	8	21	8D00 87148	12	6	8G00 31756	11A	14
8A00 31744	8	26	8A00 77929	30	13	8C00 10350	2	10	8D00 90424	25	23	8G00 66179	21	23
8A00 35408	19	10	8A00 90500	1	13	8C00 11868	7	3	8D00 90424	25	24	8G00 67963	25	16
8A00 41682	9	22	8A00 91794	24	3	8C00 32069	17	6	8D00 90425	19	11	8G00 90425	19	14
8A00 42272	28	47	8A00 93045	1	14	8C00 49525	12	3	8D00 90425	27	18	8G00 90425	19	29
8A00 43567	24	12	8AA0 60685	14	9	8C00 49557	2	26	8D00 90425	31	37	8G00 90425	20	2
8A00 43859	9	11	8AA0 62562	14	10	8C00 60831	24	24	8D00 90425	32	4	8G00 90425	21	5
8A00 46627	2	25	8AA0 62562	15	14	8C00 60831	24	24	8D00 90425	32	7	8G00 90425	22	17
8A00 47686	4	16	8AA0 62563	14	15	8C00 62609	24	9	8D00 90425	32	9	8G00 90425	27	31
8A00 48889	28	49	8AA0 62563	15	16	8C00 66525	15	38	8D00 91794	24	3	8G00 90425	9	37
8A00 49525	12	3	8AA0 69057	14	4	8C00 67963	4	27	8E00 05272	8	21	8G00 90426	14	29
8A00 49557	2	26	8AB0 12041	12	4	8C00 67997	11	19	8E00 05893	14	7	8G00 90426	16	2
8A00 55507	12	37	8AD0 12041	12	4	8C00 68666	13	8	8E00 07989	8	19	8H00 11868	7	3
8A00 57446	28	50	8B00 06725	5	37	8C00 69056	15	25	8E00 11868	7	3	8H00 38210	8	33
8A00 59596	10	18	8B00 07989	8	19	8C00 69634	30	40	8E00 32069	17	6	8I00 07989	8	19
8A00 62153	8	24	8B00 10350	2	10	8C00 70163	19	27	8E00 49525	12	3	8J00 90425	19	19
8A00 62606	24	4	8B00 11868	7	3	8C00 73093	24	9	8E00 49557	2	26	8J00 90425	20	1
8A00 62704	4	4	8B00 32069	17	6	8C00 87148	12	6	8E00 60831	24	24	8M00 90425	27	1
8A00 66179	22	22	8B00 38210	8	33	8C00 87148	12	6	8E00 67545	29	27	8P00 66179	4	30

**CATALOGO PARTI DI RICAMBIO - PARTS CATALOG  
CATALOGUE PIECES DE RECHANGE - ERSATZTEILKATALOG  
CATALOGO PIEZAS DE REPUESTO**

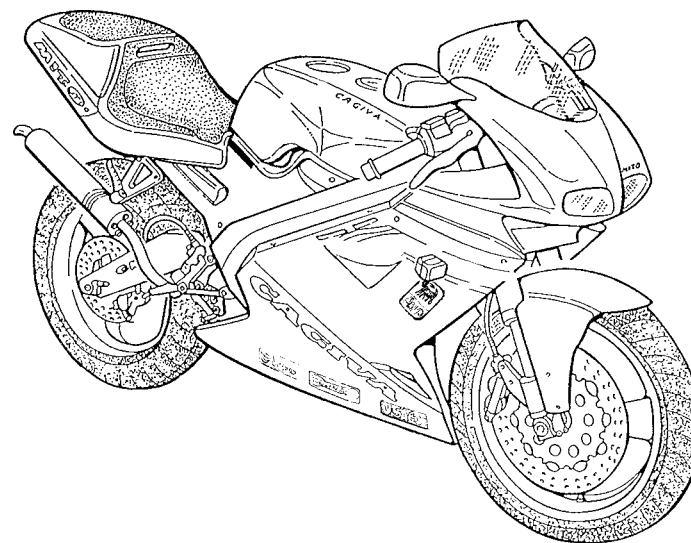

***CAGIVA***

***MITO EV-01***

**Part. N° 8000 A1085  
Ed. 01/2002**